

Radio ^{IND} Electronics

FOR MEN WITH IDEAS IN ELECTRONICS

BUILD R-E'S TONE-BURST GENERATOR FOR DYNAMIC HI-FI TESTING

More Burglar Alarm Circuits

Getting Better Sound From Cassettes

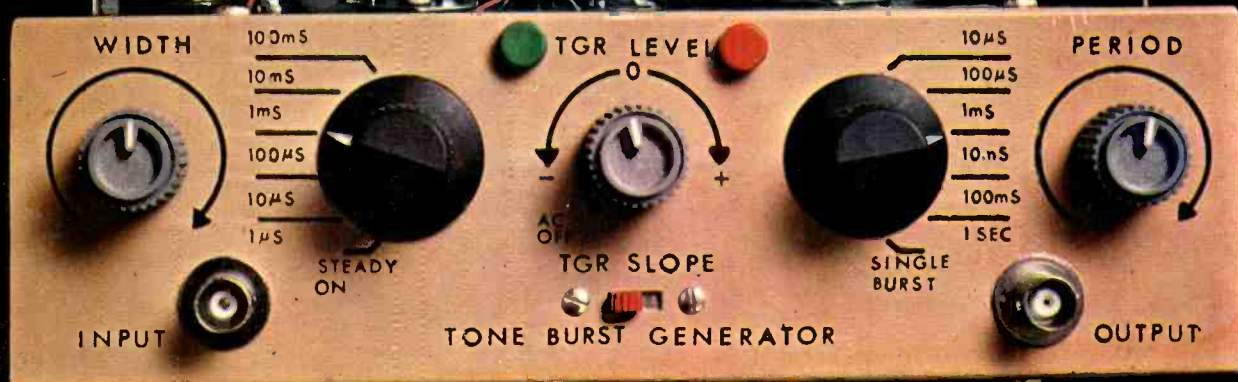
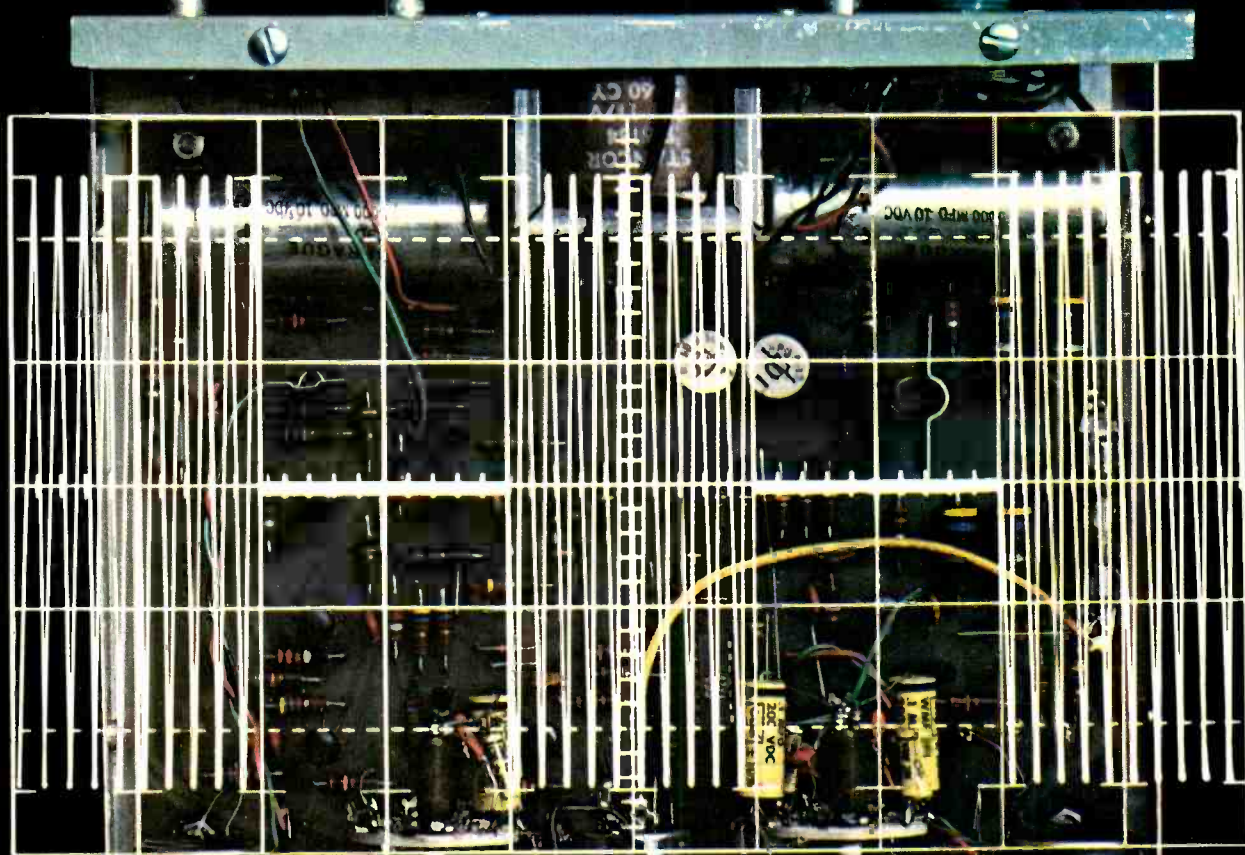

GTE Sylvania has the lines that lay it on the line.

Only GTE Sylvania gives you a choice of three different price lines in color picture tubes.

And GTE Sylvania tells you and your customer exactly what you are getting in each line.

That makes Sylvania tubes easier to sell.

You can tell your customers the advantages of the top-line *color bright 85[®] XR*. You can show them where the savings come from in the economy *color screen 85* line. And you can tell them exactly what they're getting for their money in the middle-line *color bright 85[®] RE*.

The way we see it, if we lay it on the line with you, you can lay it on the line with your customers.

Instead of just handing them a line.

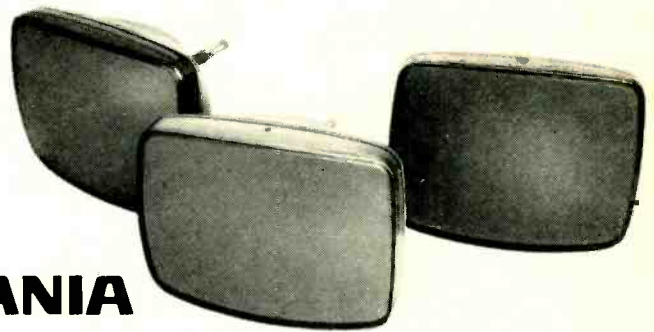

GTE SYLVANIA

	color bright 85 [®] XR	color bright 85 [®] RE	color screen 85
Sylvania rare earth red phosphors	yes	yes	yes
Other manufactured rare earth phosphors	no	no	yes
All sulfide phosphors	no	no	no
X-ray inhibiting glass	yes	no	no
New glass	yes	some	some
Reused glass	no	some	some
Regunned	no	no	some
Screen blemish specs	OEM	OEM	slightly wider than OEM
White field uniformity	OEM	slightly wider than OEM	slightly wider than "RE"
Cut off; purity currents; beam shield leakage	OEM	OEM	slightly wider than OEM

NEW & TIMELY

Volume 42 Number 7

RADIO-ELECTRONICS . . . FOR MEN WITH IDEAS IN ELECTRONICS

July 1971

IHF Recommends Wattage Rating Standard

WASHINGTON, D.C.—The Institute of High Fidelity, the audio industry's trade association, testified before the FTC at an open hearing on the proposed Consumer Audio Amplifier Wattage Ruling.

Basically, the FTC Ruling calls for all advertising and promotional material regarding the wattage (power) rating of audio amplifiers to be given as an rms figure.

The IHF's recommendations called for the specification of the IHF-A-201 test standard as the method to obtain an rms wattage rating, and asked the FTC to incorporate in their final rule re-

quirements for stating the percent of total harmonic distortion contained in the signal at the rated power; the standard use of an 8-ohm load (speaker) for tests; that total power (arithmetic sum) of each channel in multi-channel amplifiers be added and stated as the power of the amplifier; and that the power bandwidth (frequency range) of the amplifier be determined as per IHF-A-201.

The goal of the FTC Rule is to establish measurement standards to allow consumer comparison of wattage claims when evaluating home entertainment products.

METER MEASURES MICROWAVE OVEN RADIATION

ROCKVILLE, Md.—An easy-to-make and relatively low-cost meter for measuring radiation from microwave cooking ovens has been designed by HEW's Bureau of Radiological Health. The development was described by Bureau Director John C. Villforth as "a breakthrough for concerned microwave oven owners who have found it almost impossible to have ovens tested for potentially hazardous radiation leakage."

The basic problem, according to Mr. Villforth, has been that the cost of a commercial microwave radiation measuring instrument, about \$800, has discouraged its widespread use by oven repair shops and public health agencies. About \$150 will cover the cost of the new meter and the commercial microwave power density probe with which the meter is designed to be used. The meter itself can be assembled with about \$50 worth of commonly available parts by oven service technicians without special training.

Detailed instructions for making and using the meter,

including a list of parts, are provided in a Bureau report, "Inexpensive Readout for a Commercial Thermocouple Microwave Power Density Probe," by Robert L. Cloke. Copies of the report may be purchased by order number (BRH/DEP 70-31, PB 192-377) from the National Technical Information Service, Springfield, Virginia 22151. The prices are \$3.00 each for paper copies and 65¢ for microfiche. ★

MORE BURGLAR ALARMS
Five more SCR burglar alarms start on page 38. Study them, build them, test them.

EXPANDED WARRANTY ON SOLID STATE TV SETS

NEW YORK, N.Y.—Hitachi Sales Corporation of America now has a stronger warranty. On *all* solid state TV sets, the warranty is five years on transistors, two years on all other parts including the picture tube, and one year free labor when the set is brought into any Hitachi authorized service station. ★

MODIFIED AUTO AIR BAG REDUCES NOISE

ANN ARBOR, MICH.—A report on the study of the noise aspects of automobile air bag safety systems, released by the University of Michigan Highway Safety Research Institute, indicates that the uneven rush of air into the bags creates explosive noise and possible bag ruptures. The noise level during inflation of the bag is 155 dB. The researchers point out that 144 dB is the threshold of pain-

ful noise for a normal person.

The University of Michigan investigators, J. Arthur Nicholls, Perry O. Hays, and D. Roger Glass, said changes in the size and location of manifold slots could reduce the noise problem and make bag inflation more even at the same time. They built a manifold with basic modifications to show how to improve both problems. ★

PACKAGING FOR PRINTED CIRCUITS

LOS ANGELES, CALIF.—Multiflex, a new technique for producing multilayer printed circuits that bend and twist, has been announced by Lockheed Electronics Data Products Division.

Multiflex combines the techniques of multilayer and

bundle of connecting wires, was required when standard techniques were used.

The assembly time of these complex printed circuits is greatly reduced by this technique. Where space and weight are critical elements, such as for aircraft or mis-

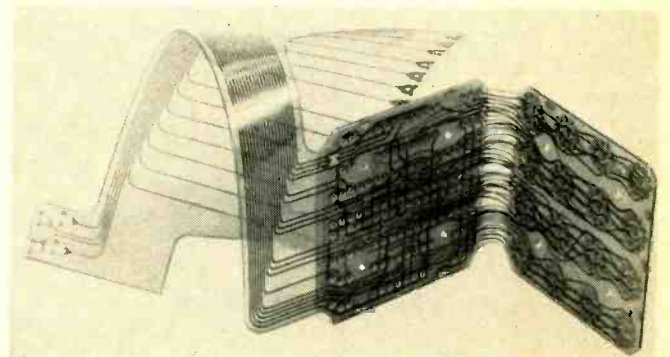

flexible circuit construction, resulting in printed circuits to fit most any shape. The design engineer can create a folded or wrap around package where before a single large board, or a prohibitive number of solder joints and a

silicon, Multiflex has application. This packaging method is also suitable for commercial electronic devices, such as desk-top mini-computer systems, where compactness and design flexibility are primary design objectives. ★

Bootleg Tape Operators Sued

PHOENIX, ARIZ.—One of the nation's largest alleged manufacturers of bootleg tapes has just been sued along with three radio stations which advertised the products and numerous dealers and dis-

tributors who are alleged to have sold them.

In addition, the U.S. District Court in Phoenix ruled for the first time in the United States that all the in-

(continued on page 6)

Radio-Electronics

FOR MEN WITH IDEAS IN ELECTRONICS

July 1971 • Over 60 Years of Electronics Publishing

BUILD ONE OF THESE

- R-E's Tone-Burst Generator** **22** Tom Annes
New solid-state instrument for dynamic hi-fi testing
- More Burglar Alarm Circuits** **38** R. M. Marston
6 more burglar stoppers
- Dancing Fluorescent Strobe** **46** Charles L. Andrews
Tripping the "light" fantastic

TELEVISION

- New TV Recorders** **13** Walter G. Salm
What's happening; what's new
- Kwik-Fix Troubleshooting Charts** **33** Forest H. Belt
Transistor color difference amplifier
- Lightning and Color TV** **48** Eugene Cunningham
When lightning strikes strange things happen
- Equipment Report** **58**
Kikusui 5121 alignment scope
- Service Clinic** **65** Jack Darr
Vertical sweep, part III
- Equipment Report** **74**
Heathkit GR-169 portable color TV kit

AUDIO—STEREO—HI-FI

- Solid-State Amplifier Design** **43** Mannie Horowitz
Small signal bias & stabilization
- Get Better Sound From Cassettes** **51** Matthew Mandl
Tips on tape for happier listening

GENERAL ELECTRONICS

- Looking Ahead** **4** David Lachenbruch
Current happenings with future overtones
- Appliance Electronics Repair** **32** Jack Darr
Electrostatic air cleaner
- Don't Throw Those Power Diodes Away** **37** J. Colt
- Electronics Helix** **42** James R. Kimsey
Round & round this puzzle goes
- IC Power Supplies** **49** Walter G. Jung
Using the μA 723 in a regulated circuit
- Unijunction Metronome** **77**
- Easy Parts Storage** **80** D. J. Holiford

DEPARTMENTS

- | | | |
|---------------------------------------|--|---|
| Coming Next Month 71 | New Products 60 | Noteworthy Circuits 75 |
| Correspondence 16 | New Semiconductors 72 | Service Notes 42 |
| New Books 73 | New & Timely 2 | Technotes 47 |
| New Literature 64 | | Try This One 59 |



Better sound can be yours by following the easy tips in this story on using tape cassettes effectively. . . . see page 51

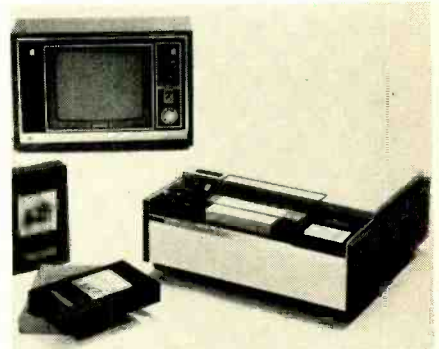

New TV recorders cost less and have cartridge or cassette loading. Price must still come down. . . . see page 13

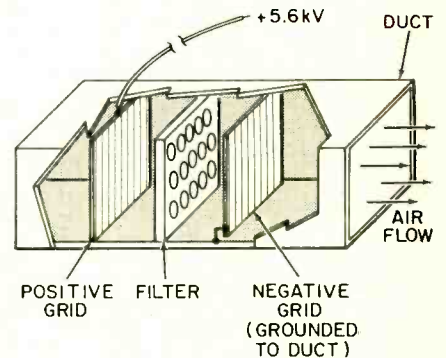

Appliance repairs got you stumped? This month we show how to handle electrostatic air cleaners. . . . see page 32

RADIO-ELECTRONICS, July 1971, Vol. 42, No. 7
 Published monthly by Gernsback Publications, Inc., at 200 Park Avenue South, New York, New York 10003.
 Editorial, Advertising, and Executive offices: 200 Park Ave. S., New York, N.Y. 10003. Subscription Service: Boulder, Colo. 80302.
 Second-class postage paid at New York City and additional mailing office. Printed in U.S.A. One-year subscription rate: U.S.
 and possessions, Canada, \$7. Pan-American countries, \$8. Other countries, \$8.50. Single copies 60¢.
 ©1971 by Gernsback Publications, Inc. All rights reserved.
 POSTMASTER: Notices of undelivered copies (Form 3579) to Boulder, Colo. 80302.



Radio-Electronics is indexed in *Applied Science & Technology Index* (formerly *Industrial Arts Index*) and *Readers Guide to Periodical Literature*

LOOKING AHEAD

Volume 42 Number 7

RADIO-ELECTRONICS . . . FOR MEN WITH IDEAS IN ELECTRONICS

July 1971

by **DAVID LACHENBRUCH**
CONTRIBUTING EDITOR

23-inch lifesaver

We're constantly hearing that television can rot your brain, immerse you in x-rays, strain your eyes and burn down your house—so it's good to learn that the federal government is now making tests to determine whether your TV set can also save your life. A simple method to detect the proximity of tornadoes and other severe storms is about to undergo official evaluation by the U.S. Weather Service. Many in the midwestern tornado belt already swear that the so-called "Weller method" of tornado detection has saved their lives.

The Weller method was discussed in this column two years ago, and since that time has been widely publicized. Now the Weather Service is asking its volunteer weather observers to use the system and report on it during this summer's tornado season. The system was developed by a self-trained meteorologist and electronics engineer, Newton Weller of Des Moines, Ia., who insists it is well-nigh infallible. It is claimed to provide what the Weather Service has been seeking for a long time—a simple detection system available to every home.

Weller's theory is based on his observation that every tornado is accompanied by an electrical "core" which is very close in frequency to television's Channel 2. The system is easy to use. If the weather is threatening (and tornado-belt dwellers recognize the general symptoms of possible tornado weather), these steps are followed: (1) Turn the TV to Channel 13 and turn the brightness down until the screen is almost black. (2) Tune to Channel 2 without touching the brightness control. Watch the screen. A lightning storm will appear on the screen as a series of horizontal streaks or flashes—the broader the bands the more severe the storm. A nearby tornado will be signaled by an increasingly steady bright white light filling the screen. If there is a station on Channel 2 in the area and the darkened picture becomes increasingly visible and remains bright, a tornado is indicated.

The system, according to Weller, can detect tornadoes 15 to 20 miles away—and if the screen lights up, it's time to seek shelter. If you live in a tornado area and use this detection system, you can help the Weather Service by making a report on the success or failure of this technique to the U.S. Weather Service, Silver Spring, Md. Send the editors of **Radio-Electronics** a copy of your report too.

CATV security blanket

Cable and master TV systems can now offer fire and burglary protection using a technique developed by Holmes Protection, Inc., a New York burglar-alarm firm. The development is being offered to existing systems on a royalty basis. Each protected home has a series of gadgets to determine whether a burglar is entering, or the temperature has reached a certain limit—standard security devices used by Holmes. If these conditions exist, lights go on at the "head end" of the CATV or master system. The technique doesn't interfere with television reception, since the signal fed back to the master station can be anywhere in the 5 to 25-MHz range, below the frequency of television. Under the Holmes plan, each security customer would be charged \$200 to \$250 for installation of the proper sensors in his home, plus \$10 to \$15 per month for the surveillance service.

RCA's home VTR

RCA is preparing a magnetic tape video recorder for home use, and there is speculation that it may be on the market next year. The company is reluctant to reveal details of the system, but it does say that its concept "could lead to a video player-recorder significantly less expensive and less complex than other magnetic tape systems being advanced for the consumer market." RCA's system uses an easy-load cartridge, is designed for recording from TV set or small TV camera. RCA has demonstrated a holographic tape videoplayer, which it still insists will be the least expensive playback-only video system. The company says it has not abandoned this "Holotape" approach, but may introduce the magnetic system for consumers who wish to record their own video. It's a good guess that the VTR will be on the market before the holographic device, and that RCA is using this method to stake its claim in what is generally assumed to be an upcoming market for VTRs.

Talkative clock

So it's the middle of the night and you have a clinical interest in what time it is but you don't want to open your eyes or turn on the light or put on your glasses. Well, it's simple—you just push the remote-control button under your pillow. And the clock says, in dulcet tones: "Three forty-four." So you roll over, all warm and comfy-like and that computer in your brain tells you that there's still three hours and 46 minutes of sack time left. This is the principle of a new clock radio by Panasonic, called, appropriately, "Tele-Time."

Tele-Time has a tape system which can call out the time to the nearest minute whenever the remote-control switch is pressed or a button pushed on the radio. Or, if you prefer an hourly reminder, it can be set to announce each hour. An alternative method is an alarm which lets you stay in bed but nags you every minute with the correct time. It will come on the market this summer, presumably in a choice of masculine or feminine voices. It has a two-reel tape player inside, one for hours, one for minutes.

The suggested list price is \$129.95, fairly high for a clock radio—but we think it's well worth it for the version with the sultry feminine voice. Panasonic denies it has plans to reduce the cost of the radio by selling commercials—"It's 7:32 AM, time to get up and use Killer After-Shave Lotion."

Long-playing tape?

Along comes a little Texas company called Graham Magnetics and tells us it has a new magnetic particle which can make possible a video or audio tape which can be run four to five times slower with the same results as today's tapes. The new particle is called "Cobaloy," a metal (not an oxide) which can be applied directly to the tape. Graham, a computer tape manufacturer, claims that its new compound will make possible home video tapes which can supply more than an hour's entertainment in the length formerly believed usable for only 15 minutes. If Graham can deliver, the development is well-nigh revolutionary in the audio, visual and computer fields—increasing tape's storage capacity by a factor of four to five. Graham did not demonstrate tape samples, but says it can be in production within a year. The Cobaloy tape, it says, will cost about the same as current chromium dioxide tapes, or about 50 percent more than standard iron oxide tapes. **R-E**

There is no substitute for training on real electronic equipment.

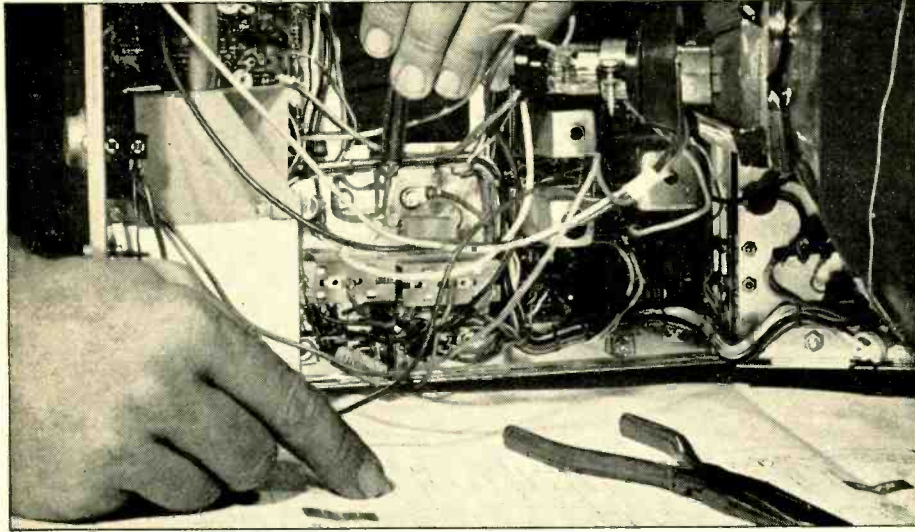

It's just as easy to train on the type of equipment technicians actually use and service.

And it's a lot more practical. Take TV Servicing, for instance.

You'll have it all over the man whose only experience has been on a TV receiver designed strictly for training purposes.

NTS Project-Method courses in Electronics combine the latest, professional equipment with easy-to-grasp lessons, texts and manuals. You build your equipment a stage at a time, and then use the equipment on projects that duplicate actual servicing problems.

It's like getting on-the-job experience at home.

Here's just some of the equipment you get to keep, and what you will learn. You'll get all the details when you receive the NTS full-color catalog.



NTS COLOR AND B&W T.V. SERVICING

You receive a color TV with many unique features, including built-in self-servicing equipment so you can make all normal test operations. You also build an AM-SW radio, solid-state radio, F.E.T. Volt-Ohmmeter, and electronic tube tester. You learn trouble-shooting, hi-fi, multiplex systems, stereo and color TV servicing.

Solid-state B&W TV
74 sq. in. picture (cabinet included)

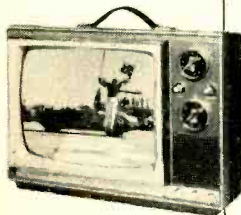

The B&W TV receiver features the latest in solid-state circuitry, making your TV training the most modern, most advanced available.

Exclusive **Compu-Trainer®**

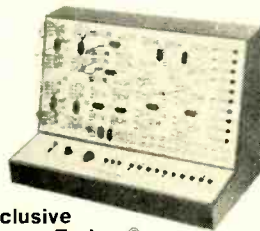

NTS ELECTRONIC & COMPUTER TECHNOLOGY

One of the 10 important kits included is this remarkable Compu-Trainer®—an NTS exclusive. It's a fully operational computer logic trainer—loaded with integrated circuits. It introduces you quickly to the how, what, and why of computers. You also receive a F.E.T. Volt-Ohmmeter and a 5" wide band oscilloscope.

Mail coupon today for free, full-color catalog that details every training program we offer. No obligation. No salesman will call.



5 watt AM transmitter receiver



NTS ELECTRONICS COMMUNICATIONS AND F.C.C.

Two exciting courses in the big-paying fields of transmitting and receiving. Either one qualifies you for your FCC First Class Radio-Telephone License. NTS assures you will pass this FCC exam within 6 months after successfully completing your course—or your tuition is refunded. You receive 14 kits to build an amateur phone 6 meter VHF transmitter plus NTS' exclusive 6 transistor solid-state radio and a fully transistorized volt-ohmmeter.

5" Oscilloscope

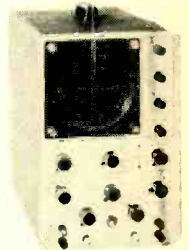

NTS INDUSTRIAL & AUTOMATION ELECTRONICS

Let NTS put you into the age of electronic controls. Systems automation is rapidly becoming the emphasis of modern industry. NTS training equipment includes a 5" wide band oscilloscope. You also get the new exclusive NTS Electro-Lab—a complete workshop. Build five industrial controls to regulate motor speed temperatures, pressure, liquid level and much more.

Please rush Free Color Catalog and Sample Lesson, plus information on course checked below. No obligation. No salesman will call.

National Technical Schools

4000 S. Figueroa St., Los Angeles, Calif. 90037

- | | |
|--|--|
| <input type="checkbox"/> Master Course in Color TV Servicing | <input type="checkbox"/> Practical Radio Servicing |
| <input type="checkbox"/> Color TV Servicing (For advanced Technicians) | <input type="checkbox"/> FCC License Course |
| <input type="checkbox"/> Master Course in B&W TV & Radio Servicing | <input type="checkbox"/> Master Course in Electronics Technology |
| <input type="checkbox"/> Master Course in Electronics Communications | <input type="checkbox"/> Industrial and Automation Electronics |
| | <input type="checkbox"/> Computer Electronics |
| | <input type="checkbox"/> Basic Electronics Dept. 206-071 |

Name _____ Age _____

Address _____

City _____ State _____ Zip _____

- Check if interested in Veteran Training under new G.I. Bill. Check if interested only in Classroom Training at Los Angeles.

CLASSROOM TRAINING AT LOS ANGELES

You can take classroom training at Los Angeles in sunny Southern California. NTS occupies a city block with over a million dollars in facilities devoted exclusively to technical training. Check box in coupon.

APPROVED FOR VETERANS

Accredited Member: National Association of Trade & Technical Schools; National Home Study Council.

NATIONAL TECHNICAL SCHOOLS

World-wide training since 1905

4000 S. Figueroa St., Los Angeles, Calif. 90037

New & Timely

(continued from page 2)

ventory, equipment and machinery used to manufacture the illegal tapes could be seized.

The suit was brought by The Harry Fox Agency of New York City on behalf of 59 music publishers in the country. ★

Used Mercury Batteries Collected

NEW YORK, N.Y.—Meyrowitz Opticians are enlisting the public in the fight against mercury pollution by calling in the worn out batteries that power hearing aids, camera light meters and watches. These mercury batteries generally end up in the water where bacteria change the mercury into methylmercury and end up in the seafood we eat, or contaminating the land. Although not the main source of mercury pollution, millions of the batteries are in use and are of significance in the problem.

Meyrowitz will see to it that these worn out batteries are properly recycled. They offer incentives to the public for turning them in. Ordinary zinc-carbon flashlight batteries do not contain mercury, and may be discarded as refuse. ★

LASER BEAM CUTS CLOTH

FREDERICKSBURG, VA.—After two years of intensive research, Genesco, in cooperation with Hughes Aircraft Company, has developed a laser cutting system and demonstrated a prototype production machine for use in the textile industry.

"The new system," explained Franklin M. Jarman, chairman of Genesco, "allows us to cut one garment at a time with amazing speed and accuracy."

Four major components

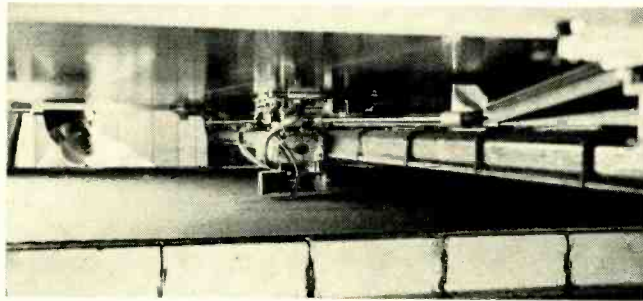

constitute the laser cutting system: a computer storing programmed cutting instructions, a positioning device, the laser and a conveyor.

A single layer of material is unrolled from a bolt and moved along the conveyor until it is directly under the positioning device. Turned on by the computer, the laser's

beam is automatically directed and intricately maneuvered above the cloth following what can be a highly complex pattern stored on tape. Gold-plated aluminum mirrors focus the beam, and silicon mirrors in a pentaprism arrangement direct the beam.

The beam cuts each garment according to programmed instructions that include directions to accommodate such matters as size and style. The conveyor then moves the cut material along. ★

Electricity Speeds Bone Fracture Healing

PHILADELPHIA, PA.—Evidence that electric current makes bone fractures heal faster has been established by a Navy study conducted by the University of Pennsylvania Medical School.

That electric charges play a role in bone growth and healing was already known, but previous investigations have been inconclusive because of the problem of delivering a constant current to the bone. Current provided to the bone decreased as tissue resistance developed. The investigators in the Navy research study solved this problem by developing a compact power pack with a transistorized circuit able to deliver a constant current regardless of changing resistance in the tissues.

The tiny power pack is implanted under the skin, with the negative electrode secured directly across the fracture and the positive electrode in a nearby location.

In the experiments, fractured leg bones of animals subjected to the current healed solidly within 18 days

(continued on page 12)

R-E's TONE-BURST GENERATOR

If you need a really special instrument to check out hi-fi stereo preamps, amplifiers and speakers, you'll want to build this generator. This month you'll find complete specifications of the instrument and details of how to build it.

Radio-Electronics

HUGO GERNSBACK (1884-1967)
founder

M. HARVEY GERNSBACK,
editor-in-chief and publisher

LARRY STECKLER, editor

Robert F. Scott, W2PWC
senior technical editor

Jack Darr, service editor

I. Queen, editorial associate

Matthew Mandl, contributing editor

David Lachenbruch, contributing editor

James A. Gupton, Jr.,
photographic electronics editor

Maxine C. Lipp, editorial assistant

Vincent P. Cicenia, production manager

Barbara Rosefelt, production assistant

H. Matysko, circulation

Cover design by Marius Trinqué

Cover photo by Phil Koenig

RADIO-ELECTRONICS is published by Gernsback Publications, Inc. 200 Park Ave. South New York, N.Y. 10003 (212) 777-6400

President: M. Harvey Gernsback
Secretary: Bertina Baer

ADVERTISING SALES

EAST
Stanley Levitan, Eastern Sales Mgr. N.Y.C. (212) 777-6400

MIDWEST/Texas/Arkansas/Okla.

Ralph Bergen,
6319 N. Central Ave.
Chicago, Ill. 60646
(312) 792-3646

PACIFIC COAST/Mountain States

J. E. Publishers Representative Co.,
8560 Sunset Blvd., Suite 601
Los Angeles, Calif. 90069
(213) 659-3810
420 Market St. San Francisco, Calif.
94111, (415) 981-4527

SOUTHEAST

E. Lucian Neff Associates
25 Castle Harbor Isle
Fort Lauderdale, Florida 33308
(305) 566-5656

SUBSCRIPTION SERVICE: Send all subscription orders and correspondence to RADIO-ELECTRONICS, Subscription Department, Boulder, Colo. 80302

MOVING? For change of address, allow six weeks, furnishing both the old and new addresses and if possible attaching label from a recent issue below. Otherwise please print clearly your name and address exactly as it appears on your label.



name _____ (please print)
address _____
city _____ state _____ zip code _____

Mail to: RADIO-ELECTRONICS
SUBSCRIPTION DEPT., BOULDER, COLO. 80302

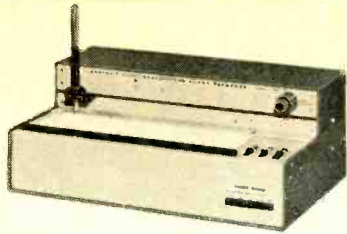

NEW IR-18M solid-state 12-speed chart recorder kit

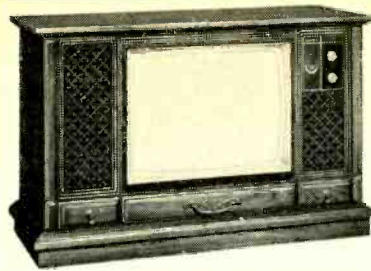

NEW GR-371MX 25" square-corner solid-state color TV kit

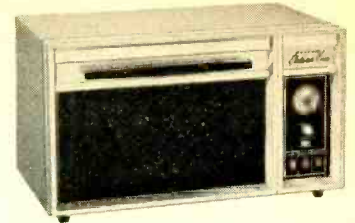

NEW GD-29 microwave oven kit



NEW IB-101 solid-state 15 MHz frequency counter kit

NEW IB-102 175 MHz solid-state frequency scaler kit



NEW IO-102 solid-state 5" scope kit



NEW IM-105 solid-state VOM kit

Seven new Heathkit® improvement ideas for home or shop

NEW! Heathkit IR-18M 10" chart recorder kit provides 12 different chart speeds...instant pushbutton selection from 5 sec/in. to 200 min/in. Digital logic delivers accuracy unobtainable with ordinary gear trains. Two input ranges permit accurate measurements from 0-1 & 0-10 mV full scale. Hi-Z input minimizes loading. 3-terminal floating input. Light-operated modulator eliminates problems of a mechanical chopper...operates at 240 Hz to reduce 60 Hz noise. Internal temperature-stabilized reference voltage eliminates troublesome reference battery. Coarse & Fine zero controls allow fast, accurate pen positioning. Other features: versatile pen holder that accepts virtually any writing instrument & hinged top for easy paper loading. For the best value going in a chart recorder, order your IR-18M now. Kit IR-18M, 15 lbs., **149.95***

NEW! GR-371MX 25" solid-state ultra-rectangular color TV. Check out the competition for standard features like these: 25" square corner Matrix picture tube for the biggest, brightest, sharpest color picture ever...high resolution circuitry plus adjustable video peaking...Automatic Fine Tuning...pushbutton channel advance..."Instant-On"...Automatic Chroma Control...factory assembled 3-stage solid-state IF and VHF & UHF tuners for superior reception, even under marginal conditions...adjustable noise limiting & gated AGC...adjustable tone control...hi-fi sound output to internal speaker or your hi-fi system. Plus your choice of installation in one of the three beautiful Heath cabinets or custom wall mounting capability. And the exclusive Heath self-service features let you do all normal adjustment & servicing, saving hundreds of dollars in service costs. If you want the finest, this is it...order your 371MX now. Kit GR-371MX, 125 lbs. **579.95***

NEW! GD-29 microwave oven...the most modern way to prepare food. Cooks up to 70% faster with better vitamin retention. Cooks on glass, ceramics, even paper plates. Low profile design fits under cupboards easily, yet has one of the largest oven capacities in the industry. Operates anywhere on standard 120 VAC current. Kit includes specially prepared cookbook. Kit GD-29, 97 lbs. **399.95*** Roll-around cart gives oven easy mobility, Model GDA-29-1, **24.95***

NEW! IB-102 Scaler and IB-101 Frequency Counter combination give you frequency measurement capability to 175 MHz at low, low cost. IB-101 counts from 1 Hz to over 15 MHz. Hz/kHz ranges & over-range indicator let you make an 8-digit measurement down to the

last Hz in seconds. 5-digit cold-cathode readout...extremely low input triggering...all solid-state with 26 ICs, 8 transistors. NEW IB-102 Frequency Scaler can be used with virtually any counter on the market to extend your measurement capability well into the VHF range...at a price far below the cost of a 175 MHz counter. 10:1 and 100:1 scaling ratios give resolution down to 10 Hz...1:1 ratio provides straight-thru counting for frequencies in range of counter. Exclusive Heath input circuit triggers at very low levels - at 100 MHz less than 30 mV is needed. A handy Test switch gives a quick, accurate check of proper operation. All solid-state; fully regulated supplies; convenient carrying handle/tilt stand. Extend your frequency measurement capability now with these two new kits. Kit IB-101, 7 lbs. **199.95*** Kit IB-102, 7 lbs. **99.95***

NEW! IO-102 solid-state 5" scope ideally suited for general purpose service & design work. Features wide DC-5 MHz response, 30 mV/cm sensitivity and 80 ns rise time. Switch-selected AC or DC coupling for greater versatility. Frequency-compensated 3-position attenuator. FET input provides hi-Z to minimize circuit loading. Recurrent, automatic-sync type sweep provides five ranges from 10 Hz to 500 kHz with vernier. External horizontal and sync inputs are also provided. One volt P-P output provides an accurate comparison voltage source. Additional features include a big 5" CRT with high visibility trace; 6x10 cm ruled graticule that can be replaced with a standard camera mount; solid-state zener-regulated supplies for extra display stability and 120/240 VAC operation. An excellent all-around scope that belongs on your bench now. Kit IO-102, 29 lbs., **119.95***

NEW! IM-105 solid-state portable VOM...an extremely rugged, highly accurate, low cost meter for hundreds of applications. High impact Lexan® case and ruggedized diode & fuse protected taut-band meter movement will suffer extreme abuse and still maintain specifications. 95° wide viewing area provides high resolution. 3% DC accuracy; 4% AC accuracy; 3% DC current accuracy. Temperature compensated. 8 DCV ranges from 0.25 to 5000 V full scale...7 ACV ranges from 2.5 to 5000 V full scale...6 DC current ranges from 0.05 mA to 10 A full scale...5 ohms ranges from x1 to x10k with center scale factor of 20...5 dB ranges from -10 to +50 dB. Other features include DC polarity reversal switch; front panel thumbwheel ohms zero; self-storing handle and fast, easy assembly. A lot of meter at a little cost...that's the new IM-105. Order yours now. Kit IM-105, 7 lbs., **47.95***

See these kits at your local Heathkit Electronic Center . . . or Send for Free Catalog

CALIF.: Anaheim, 330 E. Ball Road; El Cerrito, 6000 Potrero Avenue; La Mesa, 8363 Center Drive; Los Angeles, 2309 S. Flower St.; Redwood City, 2001 Middlefield Rd.; Woodland Hills, 22504 Ventura Blvd.; COLO.: Denver, 5940 W. 38th Ave.; GA.: Atlanta, 5285 Roswell Road; ILL.: Chicago, 3462-66 W. Devon Ave.; Downers Grove, 224 Ogden Ave.; MD.: Rockville, 5542 Nicholson Lane; MASS.: Wellesley, 165 Worcester St.; MICH.: Detroit, 18645 W. Eight Mile Rd.; MINN.: Hopkins, 101 Shady Oak Rd.; Mo.: St. Louis, 9296 Gravois Ave.; N.J.: Fair Lawn, 35-07 Broadway (Rte. 4); N.Y.: Jericho, L.I., 15 Jericho Turnpike; New York, 35 W. 45th Street; OHIO: Cleveland, 5444 Pearl Rd.; Woodlawn, 10133 Springfield Pike; PA.: Philadelphia, 6318 Roosevelt Blvd.; Pittsburgh, 3482 William Penn Hwy.; TEXAS: Dallas, 2715 Ross Avenue; Houston, 3705 Westheimer; WASH.: Seattle, 2221 Third Ave.; WIS.: Milwaukee, 5215 W. Fond du Lac.

Retail Heathkit Electronic Center prices slightly higher to cover shipping, local stock, consultation and demonstration facilities. Local service also available whether you purchase locally or by factory mail order.



HEATH COMPANY, Dept. 20-7
Benton Harbor, Michigan 49022

a Schlumberger company

Enclosed is \$ _____, plus shipping.

Please send model (s) _____

Please send FREE Heathkit Catalog.

Please send Credit Application.

Name _____

Address _____

City _____

State _____

Zip _____

*Mail order prices; F.O.B. factory.

Prices & specifications subject to change without notice.

CL-411

Circle 2 on reader service card



nri **firsts** make learning Electronics at home fast and fascinating— give you priceless confidence.

Some NRI **firsts** in training equipment

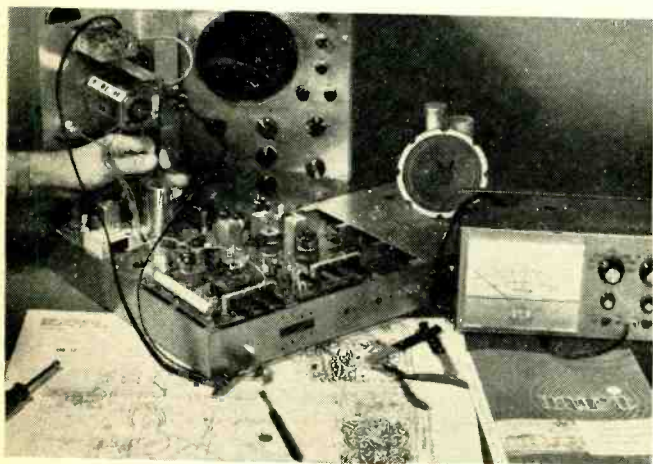

first to give you Color Television training equipment engineered specifically for education — built to fit NRI instructional material, *not* a do-it-yourself hobby kit. The end product is a superb Color TV receiver that will give you and your family years of pleasure. You “open up and explore” the functions of each color circuit as you build.



first to give you a unique, exciting digital computer *with memory* built especially for home training. You learn organization, trouble shooting, operation, programming as you build and use it. Performs the same functions as commercial computers. Lessons stress computer repair. You conduct a hundred experiments, build hundreds of circuits. A solid-state VTVM is included among ten training kits.

NRI's "discovery" method is the result of over half a century of leadership simplifying and dramatizing training at home

The FIRSTS described below are typical of NRI's half century of leadership in Electronics home training. When you enroll as an NRI student, you can be sure of gaining the in-demand technical knowledge and the priceless confidence of "hands-on" experience sought by employers in Communications, Television-Radio Servicing and Industrial and Military Electronics. Everything about NRI training is designed for your education . . . from the much-copied, educator-acclaimed Achievement Kit sent the day you enroll, to "bite-size" well-illustrated, easy to read texts programmed with designed-for-learning training equipment.

YOU GET YOUR FCC LICENSE OR YOUR MONEY BACK

There is no end of opportunity for the trained man in Electronics. You can earn \$6 or more an hour in spare time, have a business of your own or qualify quickly for career positions in business, industry, government. And if you enroll for any of five NRI courses in Communications, NRI prepares you for your FCC License exams. *You must pass* or NRI refunds your tuition in full. No school offers a more liberal money-back agreement. The full story about NRI leadership in Electronics training is in the new NRI Catalog. Mail postage-free card today. No salesman is going to call.
NATIONAL RADIO INSTITUTE, Washington, D.C. 20016

APPROVED UNDER NEW GI BILL If you have served since January 31, 1955, or are in service, check GI line on postage-free card.

designed from chassis up for your education

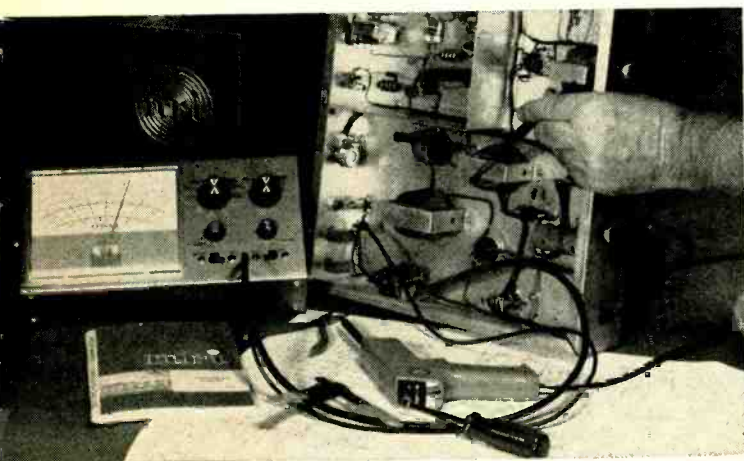

first to give you true-to-life experiences as a communications technician. Every fascinating step you take in NRI Communications training, including circuit analysis of your own 25-watt, phone/cw transmitter, is engineered to help you prove theory and later apply it on the job. Studio equipment operation and troubleshooting become a matter of easily remembered logic.

first to give you completely specialized training kits engineered for business, industrial and military Electronics. Shown above is your own training center in solid state motor control and analog computer servo-mechanisms. Telemetry circuits, solid-state multi-vibrators, and problem-solving digital computer circuits are also included in your course.

(continued from page 6)

while similar fractured leg bones not exposed to this treatment required a much longer time to fully heal naturally.

Work will continue with a variety of laboratory animals and variations in the place-

ment of the electrodes. Future experiments may eventually involve human patients suffering from bone non-union, that is, where the two ends of the bone have failed to join and would normally require graft surgery. ★

Magnetic Cooking Revived

PITTSBURGH, PA.—Another cooking technique is being developed by Westinghouse to be ready for consumers in an estimated two or three years. This is a range that

cooks without conventional heating elements or burners. Instead, it uses an oscillating magnetic circuit that directly heats the pot or pan so that the food or liquid, not the range, heats up. The "cool top" range can heat a pan of water to boiling through a newspaper without singeing the paper.

"When a pot or pan of magnetic materials such as steel or cast iron is put over the heating element, the oscillating magnetic field moves the molecules in the pan and the food is heated," explains F. R. Amthor. ★



FOUR-CHANNEL GOES FM

BUCHANAN, MICH.—Electro-Voice announced final arrangements with Bonneville International Corporation of Salt Lake City, enabling them to begin 4-channel stereo broadcasting on their chain of FM stations, using the Electro-Voice Stereo-4 encoding process.

Listeners with standard stereo receiving equipment will receive and reproduce the encoded signal as a complete two-channel stereo program, while listeners equipped with monophonic equipment will receive a full range monophonic program.

Using the EVX-4 decoder permits reproducing the entire 4-channel program. The decoder plugs into existing stereo systems. Together with two additional loud-speakers and amplifier channels the decoder translates the encoded signal into four independent sound channels. ★

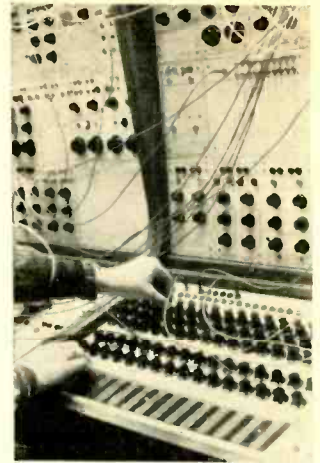

JOEL SPIEGELMAN, Resident electronic music composer of Sarah Lawrence College, at work on his synthesizer. He believes electronic music is not dehumanizing, that "it is a search into the beyond for what you do not know." His is the first electronic equipped music studio of its kind on a college campus.

BILL REGULATES REPAIRS

A registration measure designed to regulate automotive and electronic repairs is before the Ohio State legislature. It would require all service dealers be registered if they charge for repairs, prohibit untrue statements to the customer, either written or oral, and require that any documents must be filled out before the customer signs them and receives his copy.

Other sections of the bill include measures to ensure that all parts and services are listed on the invoice, used parts so designated, replaced parts returned to the customer except for those returned under warranty.

A written estimate must be given to the customer on all bills over \$50.00, and the final bill must not be larger than the estimate without the customer's consent.

In contrast with a similar bill in California, this legislation is not industry-administered. It proposes a nine member Advisory Board appointed by the Governor and composed of five members of the public, two from the automotive repair industry, and two from the electronic repair industry. **R-E**

NO RADIATION HAZARD TO TV TECHNICIANS

BALTIMORE, MD.—Final results of a Division of Electronic Products' pilot study indicate that service technicians working on color TV sets receive minimum x-radiation exposure, according to Division Director Dr. Robert L. Elder.

The study was conducted in cooperation with the Maryland State Health Department and the Electronic Industries Association in seventy Baltimore TV repair shops. Exposure data were obtained for 136 technicians who wore monitoring badges containing thermoluminescent dosimeters. The badges were worn on shirt lapels, as finger rings, and on eyeglass frames.

All service technicians' radiation dosimeter badges showed less than 0.5 milliroentgen for a one week period. "Under the circumstances, we feel that it is unnecessary to continue efforts to evaluate occupational exposure to television service technicians," said Dr. Elder. ★

Designed and manufactured in U.S.A.

NEVER A BURNOUT

IN 4 EMC DIODE-PROTECTED VOMS

NOBODY ELSE BUT EMC DESIGNS IN SO MUCH VALUE!

- Professional quality and versatility
- Lifetime protection against electrical abuse
- No meter burnout, needle damage, or fuse replacement

VOLOMETER
 Model 109A Easy Wired & Tested \$29.95
 Model 109AK Factory-to-Assemble Kit \$21.65
 20,000 Ω/v DC sens. 10,000 Ω/v AC sens.
 4½", 40μa meter. High impact bakelite case.
 5 DC voltage ranges: 0-6-60-300-600-3000v.
 5 AC voltage ranges: 0-12-120-600-1200-3000v.
 3 DC current ranges: 0-6-60-600ma.
 3 AC current ranges: 0-30-300ma; 0-3A.
 3 resistance ranges: 0-20K, -200K, -20 megs.
 5 db ranges: -4 to +67db. With carrying strap. 5¼" W x 6¾" H x 2⅞" D.

POCKET SIZE VOLMETER
 Model 102A
 Factory Wired & Tested \$17.95
 Model 102AK
 Easy-to-Assemble Kits \$14.95
 3½", 2% accurate 800μa D'Arsonval type meter. One zero adj. for both res. ranges. High impact bakelite case. 5 AC voltage ranges: 0-12-120-600-1200-3000v. 5 DC voltage ranges: 0-6-60-300-600-3000v. 3 AC current ranges: 0-30-150-600ma. 4 DC current ranges: 0-6-30-130ma; 0-1.2A. Resistance: 0-1K, 0-1 meg. 3¼" W x 6¼" H x 2" D.

Send FREE catalog of complete EMC line and name of nearest distributor. **RE-7**

Name: _____
 Address: _____
 City: _____
 State: _____ Zip: _____

EMC
 ELECTRONIC MEASUREMENTS CORP.
 625 Broadway, New York, N.Y. 10012

at last!

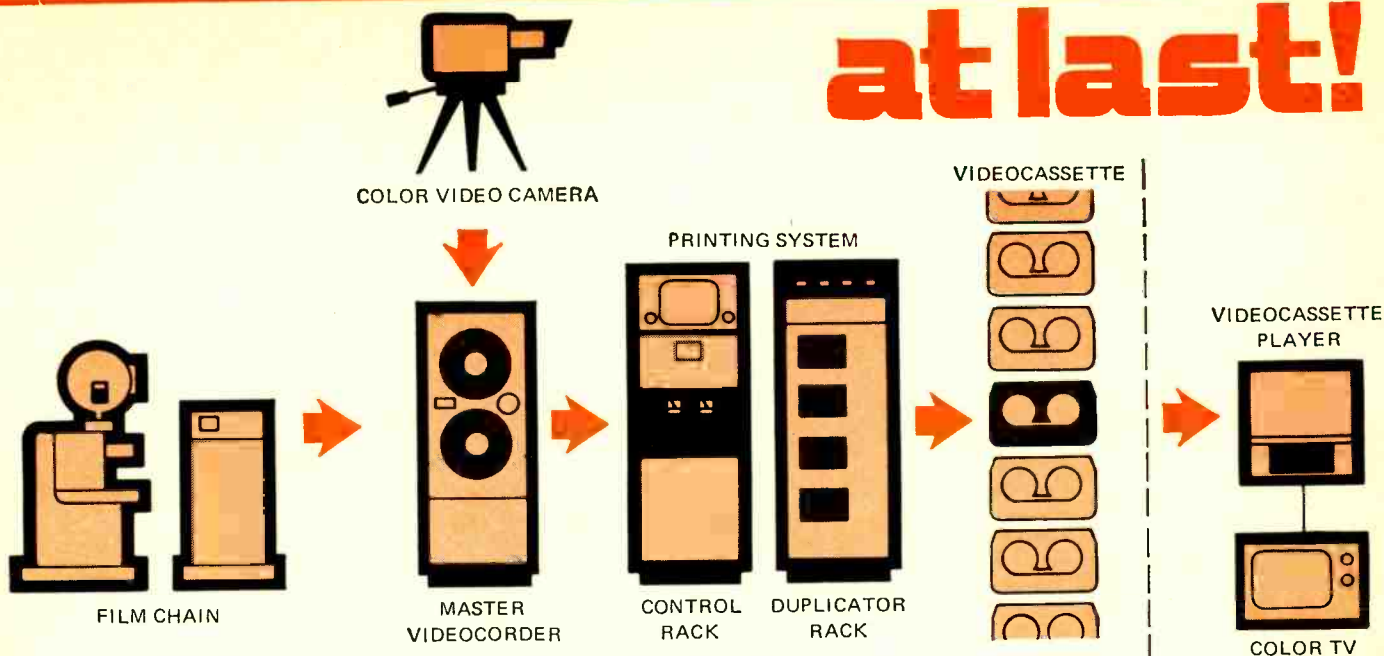

HOME VIDEO RECORDING -or is it?

by WALTER G. SALM

Cartridge VTRs are here. They're easier to use, work with color, but still carry an expensive price tag

AT LEAST ONCE EVERY COUPLE OF YEARS OR SO, SOME company announces that it has at last developed the long-awaited low-cost home video tape recording system. To be sure, the company has a "low-cost" helical-scan recorder, but its price is still too high to put it in serious contention for the home entertainment market. Usually, these new machines are snapped up eagerly by closed-circuit TV users—industry, educational institutions, the professions and some cable TV operators. Few, if any ever find their way into the home, unless some company president wants the toy for a weekend of practicing his golf swing or a presentation for an upcoming board meeting.

Generally these low-cost machines are priced in the \$600 to \$1000 range. Most use 1/2-inch tape, although a few (particularly the Ampex units) use one-inch wide tape. The new Sony uses 3/4" tape and the Akai 1/4" tape. While they may be reasonably simple to operate (after a little practice) virtually all of them require fairly frequent maintenance. Until now, few of these units have offered color. Adding a monochrome camera to the system tacks on an additional \$300 to \$600; and the TV set must be specially modified for off-the-air recording and for direct video monitoring.

There are two types of scanning methods in today's video recorders. Both use rotating head assemblies—the only way to get high enough tape-to-head velocities for the 4-MHz bandwidth needed for color TV recording. Broadcast machines use four heads (hence the name "quadruplex" recorders) in a disc that rotates against 2-inch-wide tape tracing nearly vertical scanning lines on the tape. Helical-scan machines have one or two heads embedded in a

rotating cylinder. The tape is wrapped diagonally around this cylinder so each head pass traces a slanted track.

Since tape-to-head speeds are considerably lower for helical recorders than for quadruplex units, fancy electronic tricks must be used to boost the frequency bandwidth to what is needed for color recording. After many years of practice, manufacturers have helical color techniques fairly well refined, but price and reliability have continued to be a problem.

It's nearly two years since the first of the now much-talked-about cassette video recorders was introduced. First ones to demonstrate such systems were Nippon Victor (JVC), Matsushita Electric (Panasonic) and Sony. All three systems displayed were color capable, but that's where the similarity ended.

Not too long before the cassette tape systems bowed, CBS showed its EVR (Electronic Video Recording) and hinted at its role as a home entertainment medium. Later that same year (1969), RCA showed its SV (SelectaVision) system—a direct bid for the market CBS had been talking about. Neither of these two systems use magnetic tape as the recording medium, and neither one offers recording capability. Software (program cartridges) must be purchased or rented in ready-to-play form.

EVR is a purely photographic film medium that happens to use a TV receiver for its playback screen. The cartridge contains two side-by-side movie film and sound tracks—two complete programs in monochrome or one in color. Each frame is scanned by a TV pickup tube which converts the image into suitable video information which modulates an rf signal so the program can be piped directly

into a conventional TV's antenna terminals. For color, EVR uses a monochrome picture with encoded color information on the adjacent black-and-white frame. The typical EVR playback unit costs about \$800, and the growing library of material for this medium pretty much nails down its intended role in life—an educational tool. The only thing electronic about EVR is the fact that it has an rf output and that the film can be made from a videotape with 3M's EBR (electron-beam-recording) technique.

RCA's SelectaVision uses a technique that is brand-new to the recording industry—the hologram. Holograms have been around for a number of years, mostly as laboratory curiosities. They're those strange, granular, three-dimensional photographic recordings made with a laser beam and then viewed by the light of a laser. SV uses an interference hologram embossed on an inexpensive vinyl film as the recording medium—one that can be duplicated by mass-production contact pressing—much the same way that phonograph records are stamped out.

The playback unit must also contain a laser, and the

output is read by a vidicon camera, that produces a video signal that modulates an rf carrier, and so on. In its first public showing in 1969, SV didn't look much as though it was going anywhere. The product has been substantially improved since then, and by next year, RCA might just have a decent picture to show. A consumer product by mid-1972? Not very likely, but stranger things have been known to happen.

The only other non VTR medium in contention now is ABC's ABTO—a Super-8 film that uses encoded monochrome film to produce color images. First applications are expected to be in the broadcast market, with home use following considerably later. Of all the media, probably the most interesting is the recently developed Teldec video disc introduced to an ever-more-complicated market by Telefunken. Teldec uses an ever-so-thin sheet of vinyl with mechanically modulated grooves—very much like a long-playing record. The grooves are spaced only 0.3 mil apart, giving about three times as many grooves to the inch as the average LP disc. The actual recording and playback is via hill-and-dale modulation, at the frantic speed of 1500 rpm, and the frequency bandwidth is a comfortable 3 MHz. These discs can be heat-stamped exactly the same way audio LPs are, at a manufacturing cost of about 20¢ per disc. Playing time is about 12 minutes. Presumably the minor inconvenience of this short playing time would be more than offset by the disc's very low cost and ease of storage.

For years, the recording industry has been seeking some way of standardizing helical VTRs without much success. The present situation is horrendous—especially from the standpoint of institutional users who buy many VTRs. Once a particular manufacturer's unit is settled on, then all subsequent VTRs must come from the same company if tapes are to be used on more than one machine. Up until a short time ago, there was virtually no standardization of any kind among manufacturers.

This problem has become especially acute among educational institutions, since VTR operations are often widely separated geographically. A couple of year ago, the EIAJ (Electronic Industries Association of Japan) adopted a standard (same tape speed, head configuration, drum diameter, wrap, scan lines) for machines produced in Japan for educational use. This EIAJ Type I standard has been pretty much accepted not only by Japanese firms, but by VTR producers in other countries as well. It's an admirable start, but the standard is still largely ignored.

Of the cassette systems demonstrated to date, at least three of them conform to the EIAJ Type standard. They are systems from JVC, Panasonic and Ampex. The Ampex system isn't really a cassette, but rather a reel-type cartridge with a locked-in leader that threads automatically. Sony, which has been making more noise than most about its own cassette video system, uses a non-standard 3/4-inch wide tape. There were some rumors that this would be changed to 1/2-inch tape, but hopes for standardization pretty much went out the window with Sony's recent equipment showing for the New York press.

Another, by now familiar pattern has emerged. The Sony system, originally tagged at about \$400 to \$500 in early 1970, now carries a price of \$800 for the playback deck. A recorder accessory is \$200 additional. Once again, the promise of home video recording may be delayed by high prices as institutional users buy the goods.

Most cassette video systems have one thing in common: ease of operation. Some equipment has piano key controls much like their audio cassette counterparts. Most have excellent color capability, although we're only a little closer to a low-cost color camera for the home market. At least one manufacturer, Magnavox, has announced a color camera for less than \$1000, that uses the colored filter



SONY COLOR VIDEOCASSETTE system is shown above. At the bottom left of the photo are prerecorded Videocassettes. To their right is the Sony playback unit that connects to the Sony color set at the top of the photo. **AMPEX VIDEOTAPE SYSTEM** shown below features portable black-and white camera.

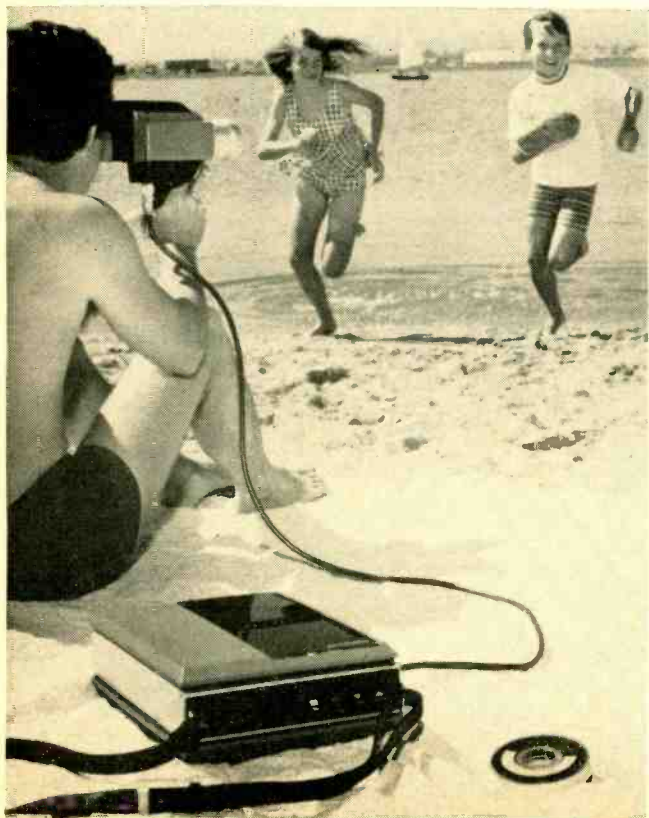

stripe principle that is basic to the RCA and Sony cameras (see **Radio-Electronics**, August, 1970, pp. 30-32, 62).

But color cameras aren't the focal point of the video cassette format. Low-cost color cameras will be available in the foreseeable future, and will certainly be compatible with most home VTR systems—if indeed these systems ever do reach the home in quantity. So far, no manufacturer has found a way to produce this equipment in large enough quantities to bring the price down to manageable levels.

One possible fly in the ointment is the emergence of pay channels on CATV systems. Such channels, for an additional monthly fee, provide first-run Hollywood movies and other viewing fare that might ordinarily be expected to be found in video cassette libraries. As such, the cable operators may well be the initial and perhaps the only long-term customers for prerecorded video tape cartridges. This could put the kiss of death on home VTR sales, but it would make little difference to the copyright owners, since they would probably receive even higher royalties from the CATV outlets than from cartridge rentals.

How soon the equipment is actually available for home use at consumer prices is anybody's guess. To listen to the various company spokesmen is to believe that hardware will be on sale across the U.S. in a couple of months. A couple of years is more like it, and you can bet it won't be at the low prices originally announced.

In the meantime, there seems to be little agreement among manufacturers on which type of oxide is best for the home video market. Naturally the ideal oxide would permit medium-speed recording with reasonably good color fidelity. To this end, Philips (Norelco) and Arvin have based their systems on chromium dioxide (Crolyn)—that seemingly miraculous DuPont formula that's supposed to solve various and sundry tape recording problems—particularly frequency response. The Arvin entry uses CrO₂ in longitudinal scan—½-inch tape whizzing past stationary heads at breathtaking speeds. But longitudinal-scan may never make it. Remember Telcan? Or its successor, Westgrove? Or their offspring, Mastercraft? The only company that ever made this type of equipment work well was Ampex, but the machine's cost was over \$4,000. All they did was prove it could be done, someday, somewhere, by someone.

There are about a dozen video tape systems designed primarily for eventual home use. Projected prices range between \$400—\$900 for color capable equipment with both record and playback capability. Of the three major cassette proponents, JVC (Nippon Victor) and Panasonic (Matsushita) use formats compatible with EIAJ Type I. The third major cassette entry, Sony, uses its own special format with ¾-inch wide tape. In a recent announcement, JVC and Panasonic indicated that they too will standardize on Sony's ¾-inch tape cassette. So much for EIAJ Type I standard.

In the meantime, Ampex is pushing ahead with production and marketing plans for its own ½-inch system which it calls "Instavision." The Ampex is probably most realistic of all those proposed. Company officials made no bones about the first customers being educators rather than homeowners. They hope to eventually lower the \$900 price tag through large volume production; then it will be a home machine. As it stands now, the Ampex is the only system that will conform to the EIAJ Type I standard, and it's not even a Japanese company!

While the Ampex machine closely resembles reel-to-reel, the tape is locked into the cartridge-like container and self-threads into the machine—much the same way the 3M stereo changer cartridges used to self-thread. That one was a disaster; hopefully this one won't be.

The only other major helical-scan entry is N. V. Philips and this one doesn't need to conform to any standard since it uses chromium dioxide tape—a whole new ball

game in itself. The ½-inch machine is inexpensive (about \$600), is a reel-to-reel type (no cartridge here) and should be available for the US market by mid-1972.

The only fixed-head machine in contention is Arvin's CVR XII. This unit uses ½-inch chromium dioxide tape travelling at a frightening 160 ips speed. The company has no definite marketing plans for now, but is the only current representative of the longitudinal scan technique.

The Avco/Admiral system, called "Cartrivision," is a cassette format that operates at the slow speed of 3.8 ips for longer playing time. It's axiomatic that slower playing speed means reduced frequency bandwidth, but in spite of this, Cartrivision seems to produce good color—at least in its public demonstrations.

The race for success in home video may well go to the first company that can get into full-scale mass production. Closest to this goal are Avco/Admiral, Sony and Ampex. Yet announced prices to date seem to high for this market, with the possible exception of the Cartrivision system. It may only be a matter of months before the trend becomes clear-cut. Or it may still take several years.

And what about chromium dioxide? One of several faults is the substance's hardness—sufficiently harder than ferric oxide to make head wear a potentially serious problem. Industry spokesmen claim to have solved this—presumably with harder pole pieces and "softer" CrO₂ through some sort of legerdemain that hasn't been fully

(continued on page 69)

JAPAN VICTOR makes the tabletop cartridge machine shown at the right. AKAI IS NEW ENTRY into VTR field with portable unit shown below. The camera is black-and-white only.



Be Safe with DeltAlert The Proven Crimestopper

Everyone knows crime is increasing steadily. In fact, statistics show that one out of every six homes will be victimized this year. What can you do about it? The DeltAlert Ultrasonic Burglar Detection & Alarm System was developed to help protect you and your family. DeltAlert effectively monitors and blankets up to 300 sq. ft. of space, utilizing the sonar principle to pick up even the slightest motion. When DeltAlert is activated, horn and lights automatically begin operating. The loud ear-shattering blasts of the high intensity horn, coupled with light drives away even the boldest intruder. At home

or work, protection begins with the DeltAlert Alarm and Detection System. It's maintenance free, and to install you simply plug it in. Order yours today, and start enjoying the feeling that comes with DeltAlert protection.

\$69.95

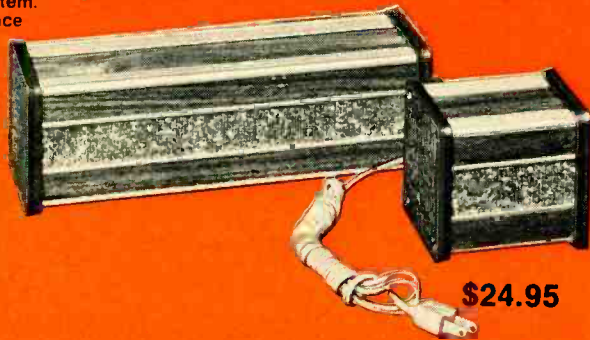

\$24.95

Here Are 8 Reasons to Put The Mark Ten B On Your Car

The Mark Ten B CD System with exclusive VARI SPARK® Circuitry will give you these substantial dollar saving advantages: 1) Eliminate 3 out of 4 tune-ups; 2) Improve combustion, reduce contaminants; 3) Install in ten minutes; 4) Instant start in all weather; 5) Dramatic increase in performance; 6) Handy switch with redundant contacts for instant return to standard ignition; 7) Two-piece housing with neoprene seals provides total dust and moisture protection; 8) Use on ANY 12-volt, negative-ground engine. Put the Mark Ten B on your car today. It will pay for itself in dollars saved.



Superior Products
At Sensible Prices

Mark Ten B (12v neg only) Only **\$59.95** ppd.

Standard Mark Ten **\$44.95** ppd.

Please send me literature immediately. Enclosed is \$_____ Ship ppd. C.O.D.

Please send: _____ DeltAlert(s) @ \$69.95 ppd.

_____ DeltaHorn(s) @ \$24.95 ppd.

_____ Mark Ten B @ \$59.95 ppd.

_____ Standard Mark Ten (Assembled) @ \$44.95 ppd.

_____ 6 Volt: Neg. Ground Only _____ Positive Ground

_____ 12 Volt: Specify _____ Negative Ground

_____ Standard Mark Ten (Deltakit) @ \$29.95 ppd.
(12 Volt Positive Or Negative Ground Only)

Car Year _____ Make _____

Name _____

Address _____

City/State _____ Zip _____

P.O. Box 1147, Grand Junction, Colorado 81501, (303) 242-9000



DELTA
PRODUCTS, INC.

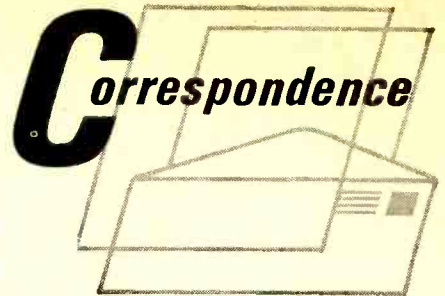

IC CONVERGENCE GENERATOR

I have just completed the article "Build An IC Convergence Generator" by John Votipka in the January 1971 issue. If you recall, my article in the December 1969 issue was entitled "Beginners Dot Bar Generator". My idea, design, circuit values and technical description were used by Mr. Votipka for his recent story, with the sole change of replacing the transistors (which are in a sense RTL's) with IC's. How do you explain this unauthorized use of someone else's material?

BENNETT C. GOLDBERG
Cinnaminson, N.J.

MR. VOTIPKA REPLIES

I was fully aware of your article and I assure you there was no intent of infringement upon anyone's rights. The only purpose being improvement, making it easier to build, more reliable, more stable, and less expensive. I do believe it fulfilled these points satisfactorily.

As far as your idea is concerned, please refer to the 1953-54 RCA and Hickok models, and you will find the tube compliment of your generator.

JOHN C. VOTIPKA
Knoxville, Md.

CAUTION IN USING PARKING LIGHTS

R. M. Marston, in his article "Automatic Parking Light Operator" in the April 1971 issue of **Radio-Electronics**, points out that some countries require parking lights to be displayed during hours of darkness. Although this is so, I have also discovered that some states (Colorado and California are two) forbid the use of parking lights alone on any moving vehicle regardless of lighting conditions. This applies, of course, only on highways and streets, and parking lights are to be used when a vehicle is parked (such as at a drive-in theatre), or to indicate that the vehicle is not moving.

A. EDWARD BROWN
Granby, Colo.

TAPE MAINTENANCE ACCESSORIES

In your April 1971 story, "Stereo On Wheels" by Eugene Walters, concerning maintenance accessories on stereo tape equipment, Mr. Walters

Circle 3 on reader service card

says he would like to see someone package that head degausser in a cartridge shape; that way, the head would be located instantly, and the pole pieces would always be kept the proper distance from the head, avoiding any possible damage. Lafayette Radio Electronics carries this exact item. I saw it in their 1970 catalog for \$7.98, stock number 28E-72307. This is for home use, 117 V ac. They also have a 12 V dc model for \$9.95, stock number 28E-72315.

Keep up the good work with the fine articles in your easy to understand magazine.

LOWELL C. GIBBS
Portland, Maine

MUSIC OF THE SPHERES VERSUS STEREO

I've been in the electronic service business for thirty-one years and have been familiar with Gernsback publications for the same period. But it does seem that of late we are not seeing eye-to-eye on the type of article published.

May I ask if you've given any thought to exploring other fields of electronics for general interest to the experimenter? Surely, all of your readers are not particularly interested in pointing 4 or 6 speakers at their heads! Fully one-half of them are not audiophiles at all.

In the fine tradition of the early Gernsback publications I ask you whether you have any plans for an amateur construction of a radio telescope? There just may be some surplus masers on the market. Some of the leading antenna manufacturers make paraboloid uhf antennas. Why not put one of your technical writers to work designing a radio telescope, perhaps using some surplus TV parts, and encourage some of your readership to tune in on the "Music of the Spheres." There are things out there that go beep-beep (Pulsars)! There are 21 centimeter radiations from Orion Nebula (overhead nightly)! There are two galaxies in collision in Cygnus!

Who knows: with mathematical probability of at least 100,000 "earths" in our Galaxy alone, one of your experimenter-readers may be the first recipient of some intelligent communication from "out there."

ROBERT M. SICKELS
Fort Lauderdale, Fla.

R-E

There once was a man named McGee,
wired his house for Closed-Circuit TV;
He tuned in on his wife
got the shock of his life,
cried "The feller I see there ain't me!"

Jack Darr



If your tuner spray doesn't say "Non-Flammable" should you be using it?

The words "Non-Flammable" on the outside of your tuner spray, tell you a lot about the ingredients on the inside.

Most obvious is that they will not support combustion and so are safe. Your customer's property is protected . . . and so are you.

But the words "Non-Flammable" also have a hidden meaning. They tell you about the kind of ingredients inside the can.

For example, for cleaning and degreasing tuner contacts, Freon* has the best solvent, washing and degreasing action of any product, and is

one of the finest propellants known for aerosols. Freon is also Non-Flammable.

For lubricating action Silicone is non-evaporating, inert, lasts almost indefinitely, will not gunk up contacts and is one of the most efficient known. Silicone lubricant, too, is Non-Flammable.

That's why Chemtronics uses these ingredients in its tuner sprays. They're the very best. They're also Non-Flammable, and Chemtronics says so right on the label.

Non-Flammable. Think about it. Look for it.

*Trade name E. I. Dupont.



CHEMTRONICS INC.

1260 Ralph Avenue, Brooklyn, New York 11236

Circle 4 on reader service card

10 Reasons why RCA Home Training is your best investment for a rewarding career in electronics:



Performing transistor experiments on programmed breadboard — using oscilloscope.

1 LEADER IN ELECTRONICS TRAINING

When you think of electronics, you immediately think of RCA... a name that stands for dependability, integrity, and pioneering scientific advances. For over half a century, RCA Institutes, Inc., a subsidiary of RCA, has been a leader in technical training.

2 RCA AUTOTEXT TEACHES ELECTRONICS FASTER, EASIER, ALMOST AUTOMATICALLY

Beginner or refresher, AUTOTEXT, RCA Institutes' own method of programmed Home Training will help you learn electronics more quickly and with less effort, even if you've had trouble with conventional learning methods in the past.

3 WELL PAID JOBS ARE OPEN TO MEN SKILLED IN ELECTRONICS

RCA Institutes is doing something positive to help men with an interest in electronics to qualify for rewarding jobs in this fascinating field. There are challenging new fields that need electronics technicians... new careers such as computers, automation, television, space electronics where the work is interesting and earnings are greater.

4 WIDE CHOICE OF CAREER PROGRAMS

Start today on the electronics career of your choice. On the attached card is a list of "Career Programs", each of which starts with the amazing AUTOTEXT method of programmed instruction. Look the list over, pick the one best suited to you and check it off on the card.

5 SPECIALIZED ADVANCED TRAINING

For those already working in electronics or with previous training, RCA Institutes offers advanced courses. You can start on a higher level without wasting time on work you already know.

6 PERSONAL SUPERVISION THROUGHOUT

All during your program of home study, your training is supervised by RCA Institutes experts who become personally involved in your efforts and help you over any "rough spots" that may develop.

7 HANDS-ON TRAINING

To give practical application to your studies, a variety of valuable RCA Institutes engineered kits are included in your program. You get over 250 projects and experiments and as many as 22 kits in some programs. Each kit is complete in itself. You never have to take apart one piece to build another. They're yours to keep and use on the job.

8 FCC LICENSE TRAINING—MONEY BACK AGREEMENT

Take RCA's Communications Career program—or enter with advanced standing and prepare immediately for your 1st, 2nd, or 3rd class FCC Radio Telephone License examinations. RCA Institutes money-back agreement assures you of your money back if you fail to pass the FCC examination taken within 6 months after completing the course.

9 CONVENIENT PAYMENT PLANS

You get a selection of low-cost tuition plans. And, we are an eligible insti-

tution under the Federally Insured Student Loan Program.

10 RCA INSTITUTES IS FULLY ACCREDITED

RCA Institutes is an accredited member of the National Home Study Council. Licensed by N. Y. State—courses of study and instructional facilities are approved by the State Education Department.

**VETERANS: TRAIN
UNDER NEW GI BILL**

SEND ATTACHED POSTAGE PAID CARD TODAY! FREE DESCRIPTIVE BOOK YOURS WITHOUT OBLIGATION!

If reply card is detached, send this coupon today.

RCA INSTITUTES, INC.
DEPT. 758-007-1
320 W. 31 ST.
NEW YORK, N. Y. 10001

Please send me FREE illustrated career catalog. I understand that I am under no obligation.

Name _____

Address _____

City _____

State _____ ZIP _____

Age _____

Veterans: Check here

Construction of Multimeter.

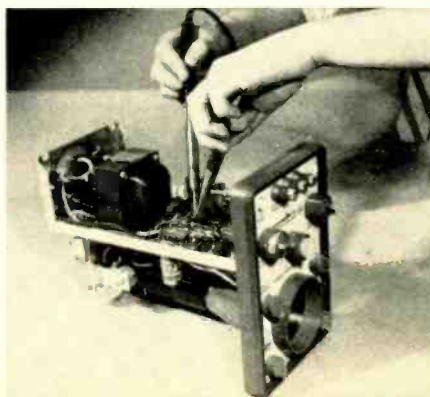

Construction of Oscilloscope.

Temperature experiment with transistors.

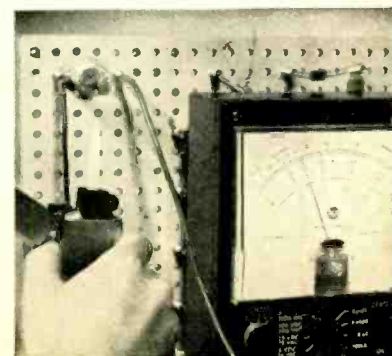

RCA

Tune up your stereo: build a TONE-BURST generator

A very special piece of test gear that's a must for your audio test bench. Use it to check out speakers, amplifiers, preamps and other audio equipment. You can build it for about \$100.

by TOM ANNES

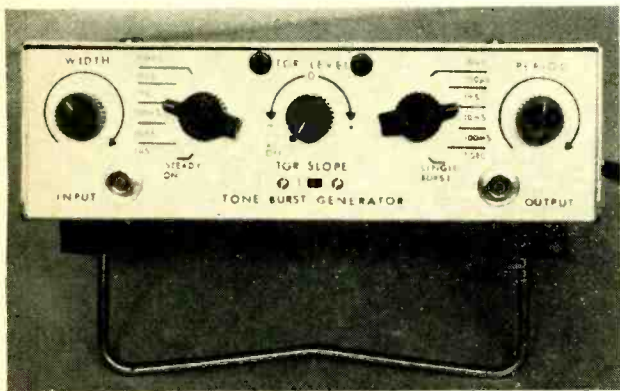

AMPLIFIERS, SPEAKERS, AND OTHER SOUND COMPONENTS WERE first tested using sine waves, dc transient response checking followed. This is usually done with a dc pulse or square waves. Today, testing with ac transients or tone bursts is becoming more common. After all, a tone burst more closely approximates musical sounds than a square wave.

A tone burst is generated by switching a steady tone on and off with an electronic gate. The control mechanism for this gate must determine how long the gate is open and closed. The bursts should be phase coherent. For example, each burst must start at the same point of a cycle of the gated signal. To do this, we must be able to control the switching of the gate. Commercial units that can do this have been available for several years, but cost \$500.00 or more.

Several construction articles have also been published on simple tone-burst generators; however, these units lacked the flexibility to be a really versatile unit. The tone-burst generator in this article is a flexible, high-frequency, high-performance unit that can be built for about \$100. It has features that are not available in commercial units. Little goodies like remote single-burst reset, 2-MHz bandwidths at the 3-dB point (the prototype operates to 7.5 MHz), and it can feed coax lines down to 50-ohm impedance.

As with any design, there is a trade off between cost, versatility, and operator convenience. A simple switch or pushbutton can be used as a tone-burst generator but it really isn't very versatile. On the other hand, you can build in every feature you could possibly dream of but who could afford it? This unit was designed and built to give maximum flexibility and versatility per dollar spent. With this economy in mind, all calibration adjustments were eliminated. The features of counted pulses in the burst was deleted from the design because it didn't offer enough versatility for the extra cost. Transistors are used where they give better performance per dollar and ICs where they have performance cost advantage. The proof of the pudding, so to speak, is best told by the specifications and oscilloscope trace photographs.

Tone-burst generators have many more uses than checking acoustics of auditoriums and loudspeaker distortion. When

it comes to amplifiers, they are used to check overload recovery characteristics. The newer hi-fi amplifiers that have a music-power rating must be checked with a tone-burst generator because they are unable to sustain full output. I have found this unit great for measuring the bandwidth of tuned amplifiers and the Q's of tuned circuits. It is also ideal as a burst generator in ultrasonic experiments.

This tone-burst generator, because of its wide frequency response and excellent transient response, will find applications in pulse work. For example, it can gate a pulse generator to produce bursts of pulses. If the burst width is reduced to two pulses, you have a pulse-pair generator; a needed item when experimenting with pulse spacing decoders. The uses that this unit can be put to is only limited to the ingenuity of the person using it. For complete details on how to use the tone-burst generator see the August 1971 (next month's) issue of *Radio-Electronics*.

Construction fundamentals

To reduce the chance of error, the following points should be reviewed before you start to build the generator.

1. All $\frac{1}{2}$ -watt resistors (except R50) have 0.700" lead spacing. Use a lead bending jig, such as a Triad MK-2, slot No. 8, if possible.
2. All 33-pF capacitors have a 0.250" lead spacing.
3. All components and jumpers are mounted parallel with an edge of the board. No parts are mounted on a diagonal.
4. All transistors (except Q1 and Q2) have their leads in a TO-5 configuration. Q7 will fit the board without bending leads. All other transistors must have their leads bent. The center lead, which is the base lead, will have to be offset from the other two leads by bending it towards the flat on the transistor case.
5. The four JFET's are in the same style case as the other plastic transistors. Bend their leads the same way.
6. Q1 and Q2 are held together (thermally) by a clip. This requires keeping their leads closer together and bending the center or base lead of these transistors away from the flat on the transistor case. NOTE: Because of the tight lead spacing of Q1 and Q2, be very careful not to short them when soldering.
7. All plastic cased transistors have the flat part of the case parallel with an edge of the board. The bottom of the cases should be about $\frac{1}{4}$ " above the board.
8. IC1 through IC6 have eight leads each, and can be inserted eight different ways. Seven of them are wrong. These IC's have a flat spot on the case next to pin 8. Pin 8 is marked for identification on the board by a dot on the inside of the lead pattern. Space them about $\frac{3}{16}$ " or $\frac{3}{8}$ " above the board.
9. IC7 has a circle on the top of the case next to pin 1. The board has a dot next to pin 1.
10. IC7 is shown in a socket in the photographs. The IC may be soldered directly into the board. The socket was used in the prototype for convenience.
11. All potentiometers and rotary switches are secured to the panel with a trim washer and a small ($\frac{1}{2}$ " across the flats) nut on the outside of the panel.
12. On potentiometers with $\frac{1}{4}$ " long bushings, bend over

the locating lugs and put on a lock washer before inserting it in the panel. On the rotary switches and potentiometers with $\frac{3}{8}$ " long bushing, use a nut (large or small) behind the lock washer. Adjust the position of this nut on the bushing to permit only one or two threads to extend beyond the outside mounting nut. If you do this, the locating lug may not have to be bent over.

The unit is built into a custom-made case $8\frac{1}{2}$ inches wide, $2\frac{1}{2}$ inches high, and 7 inches deep. If you choose to build your own case, use .040 inch thick, quarter hard aluminum for the front, back, and bottom. Threaded inserts pressed into the bottom, front, and back permit bolting the front and back to the bottom and attaching the lid. The lid can be made from a softer alloy .063 inches thick. If you make or adapt a case, use the printed circuit board as a template to locate four bolt holes in the bottom of the case to mount the feet and the circuit board.

Start assembling your generator by mounting the feet on

the bottom. Secure the screws that come up through the bottom with a lock washer and *two* nuts. The second nut gives added spacing between the circuit board and the bottom plate. The front feet used with the tilt bail require a second bolt which should be just long enough to allow one nut and lock washer on the inside.

Start wiring the printed circuit board by installing the uninsulated jumpers. Use No. 20 or 22 tinned copper wire here. Next, install the diodes, capacitors, resistors, and fuse block. Use lead-bending jigs if you have them to speed the work and make a neater job. Install Q7 with a mounting pad between it and the board. Clip Q1 and Q2 together and then insert them into the board. Install the rest of the transistors and IC's. Q7 and Q16 have heat sinks. Install them last. Install the insulated jumper. Use sleeving over the same type size wire you used for the other jumpers.

Install all wires listed in Table 1. Points 4, W, X, and Y have solder terminals. Wires will be soldered to these points

TONE-BURST SPECIFICATIONS

OUTPUT SIGNAL

A gated replica of the input signal without phase inversion.

INPUT IMPEDANCE

10,000 ohms

OUTPUT IMPEDANCE

About 2 ohms when operating within the dynamic range of the amplifiers. Capable of driving any resistive load from infinity to 50 ohms. Output is short-circuit proof.

INSERTION LOSS (Output On)

Less than 1 dB at 1 kHz when working into 50 ohms.

INSERTION LOSS (Output Off)

Greater than 60 dB, dc to 2 MHz, any load.

BANDWIDTH (50 ohms load)

Dc to 2 MHz (3 dB point) usable to 5 MHz.

TRANSIENT RESPONSE (10% to 90% points)

170 nanoseconds rise and fall time.

OVERSHOOT AND RINGING

Too low to measure.

DELAY (Input to Output)

70 nanoseconds.

BURST WIDTH

Adjustable from 1 microsecond to 100 millisecond, plus steady-on provision to allow adjusting external equipment.

PERIOD (Between commencement of bursts.)

Adjustable from 10 microseconds to 1 second, plus single-burst provision.

GATE SWITCHING

Switching level and slope selectable with front panel controls. Switching is phase coherent with input signal or external sync.

GATE STATUS

Indicated by red and green "traffic lights" on front panel.

SYNC OUT

Plus 3.6 volts from a source of 640 ohms with output on. About 0.2 volts with output off.

TERMINALS

BNC connectors used for all signal and sync connections, making it compatible with modern equipment.

PHOTO 1

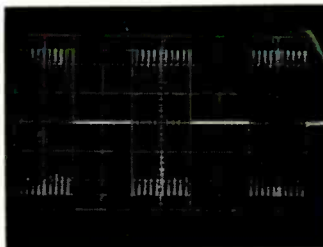

A 10 kHz signal gated 10 cycles on and 10 cycles off. (Sweep speed 500 μ sec/cm.)

PHOTO 2

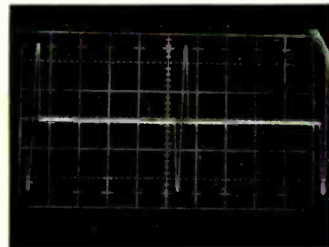

One cycle of a 1-MHz signal gated on every 10 microseconds. Note the clean switching. (Sweep speed 2 μ sec/cm.)

PHOTO 3

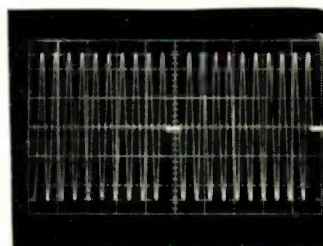

10 cycles of a 1.1-MHz signal gated on every 11 cycles. This photograph shows that the duty cycle of the burst can exceed 90% for some period settings. At least 80% duty cycle is obtainable at any period setting. (Sweep speed 2 μ sec/cm.)

PHOTO 4

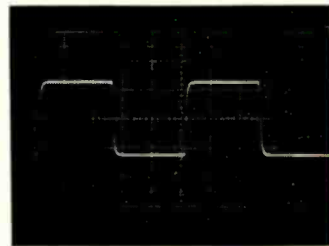

A 100-kHz square wave out of the unit. The rise and fall times (10% to 90% points) is about 170 nanoseconds. Note the clean response, free of overshoot and ringing. (Sweep speed 2 μ sec/cm.)

PHOTO 5



A sawtooth waveform gated 3 cycles on and 4 off. This photograph proves the low distortion of the unit. It also gives an idea of its flexibility.

PHOTO 6



10-microsecond pulses spaced 50 microseconds. This signal was gated by the tone burst generator to produce these pulse pairs every 400 microseconds. (Sweep speed 50 μ sec/cm.)

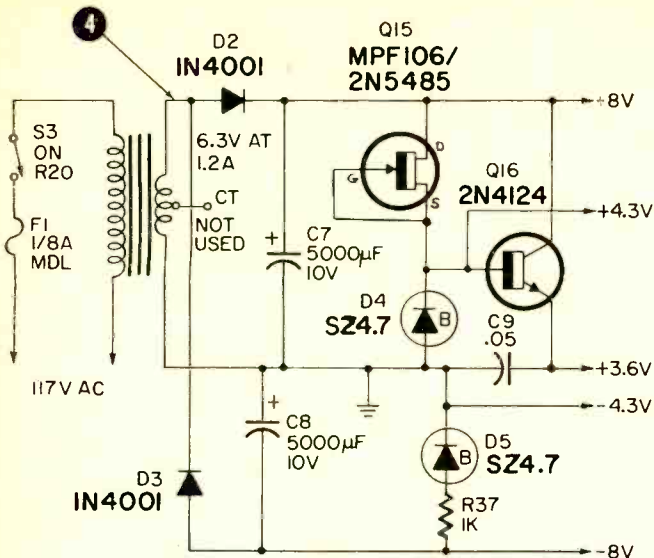

HOW IT WORKS

The input amplifier Q1 and Q2 is a buffer amplifier. The output of this amplifier drives the output amplifiers Q6 and Q7 providing Q3, Q4, and Q5 in the shunt gate are back-biased. At zero bias, these JFET's shunt the signal to ground. Each JFET gives 20 dB of attenuation. This gate is back-biased (or zero biased) by the gate driver Q8. Q9 supplies a neutralizing signal for the switching transients.

IC1, IC2, and IC3 form the trigger circuit. With S5 in the internal (INT) position, the input signal is converted into a string of pulses. These pulses toggle the control flip-flop IC4 when IC4 is enabled. The output of IC4 drives the gate driver, the sync out amplifier, and the status-lamp drivers, Q10 and Q11.

Let us start with IC4 in the 1 state. This will turn the output at J2 off. The width and period multivibrators are in their stable state. This disables the lockout transistors Q13 and Q14. A pulse from the trigger circuit causes IC-4 to flip to the 0 state. This back-biases the JFET's in the gate, letting the input signal through to the

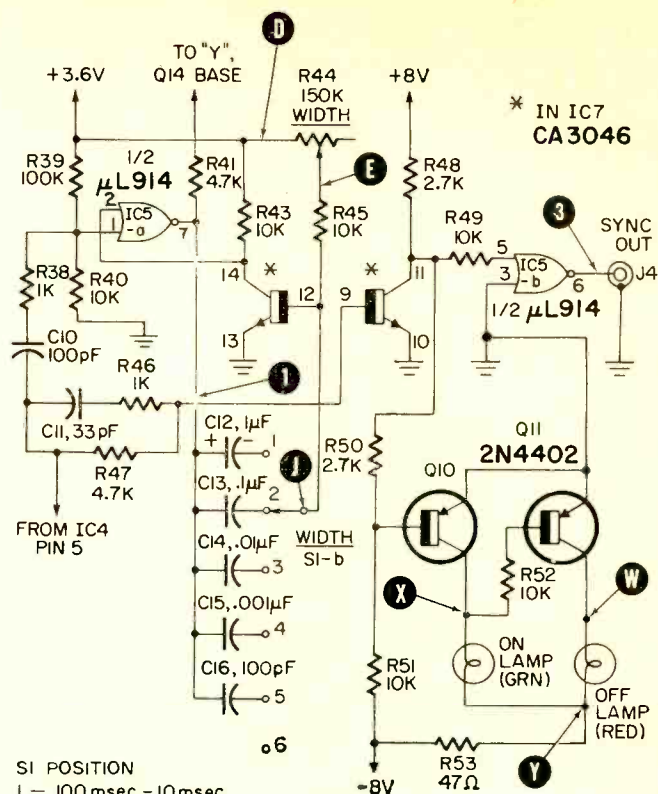

- SI POSITION
- 1 - 100msec - 10msec
 - 2 - 10 - 1msec
 - 3 - 1msec - 100µsec
 - 4 - 100µsec - 10µsec
 - 5 - 10µsec - 1µsec
 - 6 - STEADY ON

output. This triggered both the width and period multivibrators. The lockout transistors Q13 and Q14 are now energized and IC4 stays in the 0 state. When the width multivibrator times out, the next trigger from the trigger circuit causes IC4 to flip to the 1 state. The signal at J2 is now turned off. When the period multivibrator times out, IC4 will be enabled. The next pulse from the trigger circuit will cause IC4 to flip and start the same sequence over again.

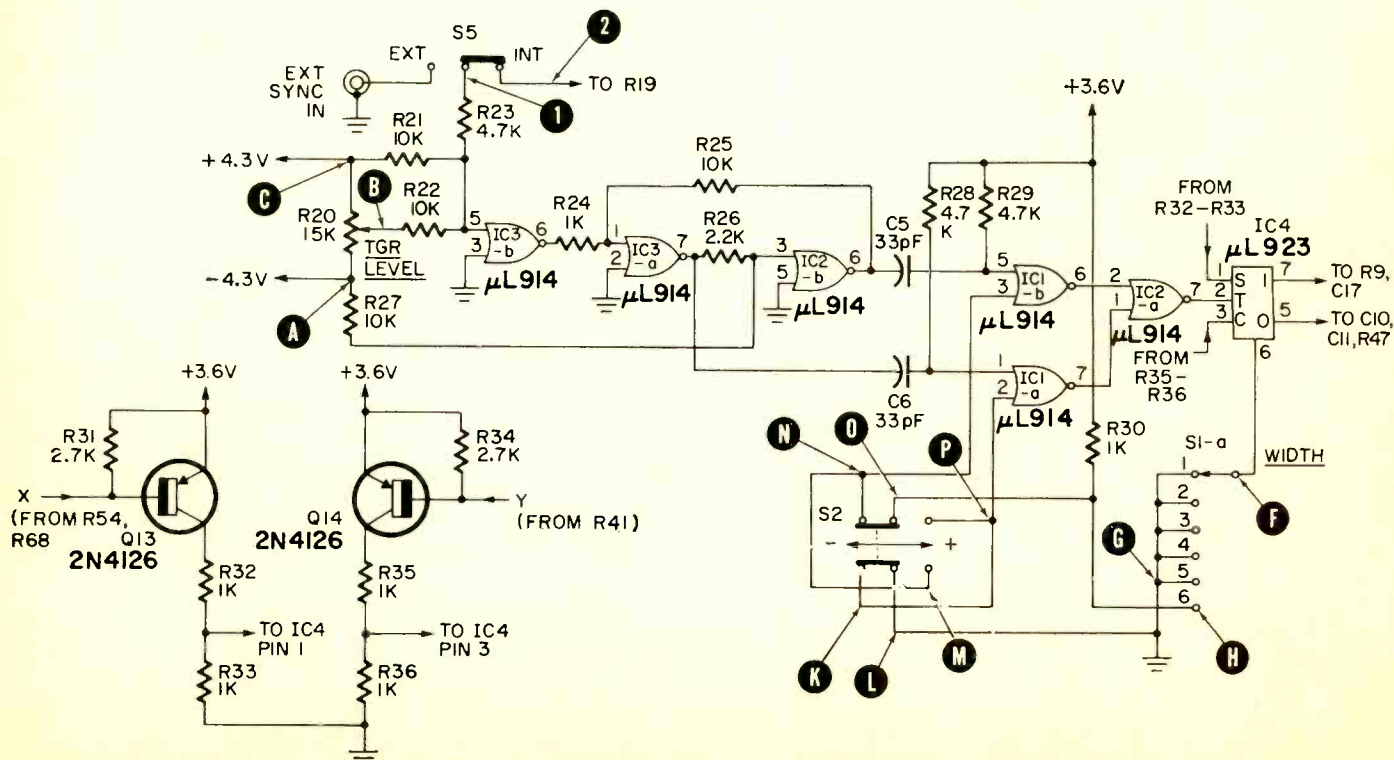

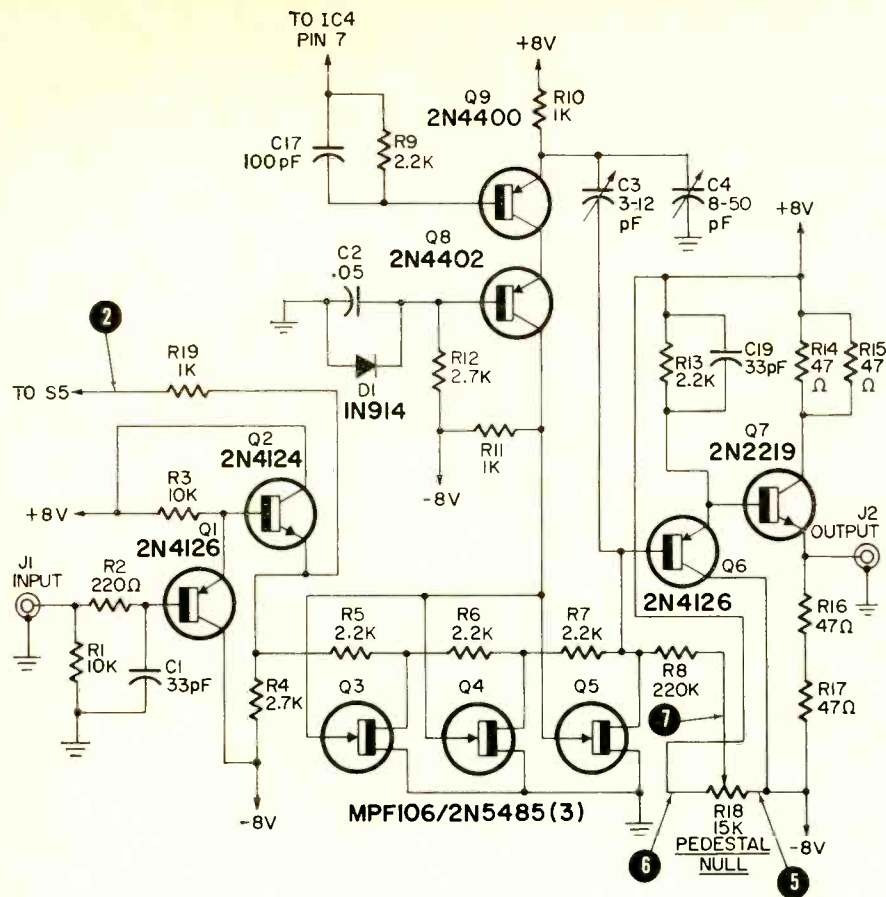

PARTS LIST

- Resistors 1/2-watt 10% unless noted**
 R1, R3, R21, R22, R25, R27, R40, R43, R45, R49, R51, R52, R57, R60, R65, R69—10,000 ohms
 R2, R66—220 ohms
 R4, R12, R31, R34, R48, R50, R70—2700 ohms
 R5, R6, R7, R9, R13, R26—2200 ohms
 R8, R71—220,000 ohms
 R10, R11, R19, R24, R30, R32, R33, R35, R36, R37, R38, R46, R55—1000 ohms
 R14, R15, R16, R17—47 ohms, 2 watts
 R18—pot, 15,000 ohms, 1/2 watt, linear
 R20—pot, 15,000 ohms, 1/2 watt, linear, with spst switch
 R23, R28, R29, R41, R47, R58, R59, R68—4700 ohms
 R39, R56, R61, R62, R64—100,000 ohms
 R44—pot, 150,000 ohms, 2 watts, linear
 R53—47 ohms
 R63—pot, 1.5 megohms, 2 watts, linear
 Note: Resistors R42, R54 and R67 were removed from the circuit during development, and, for this reason, do not appear on the schematic and parts layout.
 C1, C5, C6, C11, C19—33 pF disc
 C2, C9, C32—.05-μF 20-V disc
 C3—3-12 pF Trimmer
 C4—8-50 pF Trimmer
 C7, C8—5,000-μF 10-V electrolytic (Sprague 39D or equal)
 C10, C16, C17, C18, C24, C25, C26—100 pF disc
 C12, C20, C28—1-μF 35 or 50-V electrolytic (Sprague 196D or equal)
 C13, C21, C29—1μF 200-V Mylar (CD WMF201 or equal)
 C14, C22, C30—.01-μF 200-V Mylar (CD WMF2S1 or equal)
 C15, C23, C31—.001-μF 200-V Mylar (CD WMF2D1 or equal)
 C27—220 pF disc
 Q1, Q6, Q13, Q14—2N4126
 Q2, Q12, Q16—2N4124
 Q3, Q4, Q5, Q15—MPF106/2N5485
 Q7—2N2219
 Q8, Q10, Q11—2N4402
 Q9—2N4400
 IC1, IC2, IC3, IC5, IC6—μL 914
 IC4—μL 923
 IC7—CA3046

- Diodes**
 D1, D6, D7—IN914
 D2, D3—IN4001
 D4, D5—SZ 4.7, 4.7-V, 1-W Zener (Schauer)
 S1, S4—2-pole 6-position rotary (Centralab PA-2003 or equal)
 S2, S5—dpdt slide switch
 S3—on R20
- Other Parts**
 Dual Transistor Clip, Wakefield—239-M
 Heat sink, Wakefield—292-A
 Heat sink, Wakefield—296-4
 1 TO-5 transistor mounting pad
 3 insulated terminals tapped 4-40
 1 fuse, Buss, MDL 1/8 A
 1 fuse holder
 2 lamps, Sylvania 6ES
 1 lamp cover, red, Sylvania 38001
 1 lamp cover, green, Sylvania 38004
 1 power cord
 1 power cord, strain relief.
 1 transformer, Stancor P-6134
 1 lug type terminal strip, Cinch-Jones 51B
 5 BNC connectors (J1-J5) to mate with holes punched in case
 1 fiberglass printed circuit board
 4 round pointer knobs
 2 bar knobs
 1 case

THE FOLLOWING PARTS ARE AVAILABLE FROM:
TOOLS FOR ELECTRONICS
 P. O. BOX 2232
 DENVER, COLORADO 80201
 1 printed circuit board, drilled, with solder terminals—\$14.50
 Set of semiconductors and heat sinks—\$24.00
 Finished case with lettered front and rear panel, knobs, tilt bail, lamp mount, feet and hardware—\$29.50
 Set of electronic parts (switches, resistors, capacitors, etc.) less semiconductors—\$45.00
 Complete kit of all parts—\$105.95
 Colorado residents add 3% tax.
 Prepaid orders sent postpaid within the 50 states.

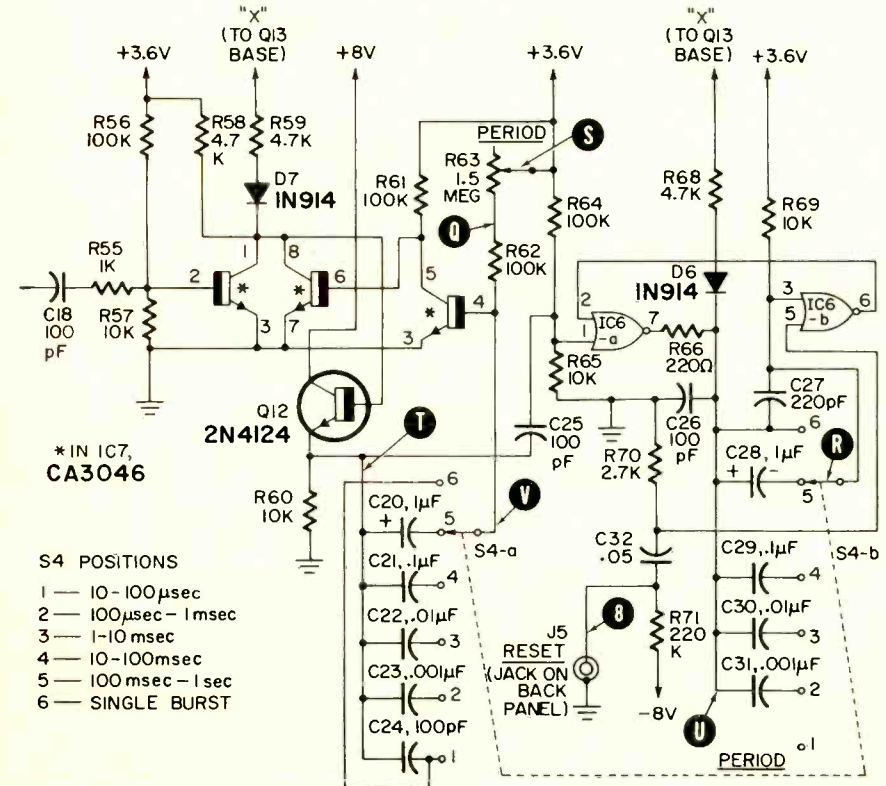

THESE FIVE SCHEMATICS comprise the various sections of R-E's Tone-Burst Generator. The schematic has been divided into sections for the constructor's convenience. A description of how the circuit works is on the facing page. Note capacitor C18 in the schematic directly above. The dangling lead at the left connects to

IC4, pin 5. After you have built and are using your Tone-Burst Generator, drop R-E's editors a note and tell them how you are using your generator. The information will be of value to other readers and we will pass it along in our correspondence columns. Applications are limited only by your ingenuity.

during final assembly. Check your work. If you are satisfied, mount the board on the bottom plate by placing it over the screws and securing it with No. 6 nuts without lock washers. Set this assembly aside for now and start on the front panel.

Front panel assembly

Start the front panel assembly by mounting J1 and J2. Next, mount R44 and R63. Make sure you use the **150,000-ohm** potentiometer for the WIDTH control and the **1.5-megohm** pot for the PERIOD control. Mount S2 with No. 2 screws, nuts and lock washers. Insert the GATE STATUS lamps into the clips on the mounting bracket. Place the colored lens caps over the lamps, with green on the left, as seen from the front. Now position this assembly on the front panel with the lens cap protruding from the front panel. Next, mount R20 to secure this lamp assembly.

Rotary switches S1 and S4 have six positions; numbered 1 through 6. Position 1 is full counterclockwise on S4 and fully clockwise on S1.

Prepare S1 by mounting an insulated terminal on the upper strut bolt. Use this for a tie point for mounting C12 through C16. C12 is a polarized electrolytic. The positive side must go to the tie point. Strap switch contacts 1-a through 5-a together, then mount S1 on the front panel.

Prepare S4 by mounting an insulated terminal on each strut bolt. Mount the timing capacitors C20 through C24 on the "a" section and use the lower insulated terminal as a tie point. NOTE: Positive side of C20 must go to the insulated terminal. Jumper switch terminal a-1 to a-6. Mount C28 through C31 on the "b" section. Use the upper insulator as a

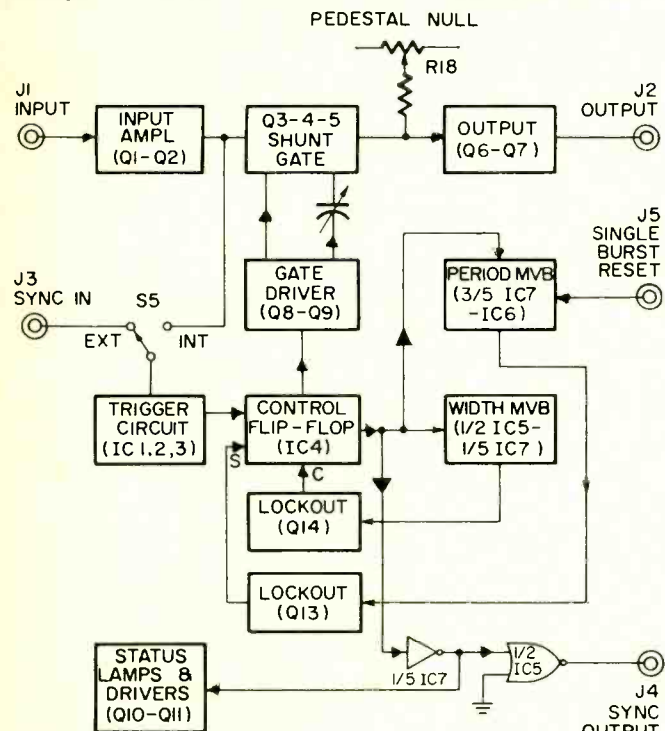

BLOCK DIAGRAM OF THE GENERATOR shows how the various circuits interconnect and which semiconductors are in each section.

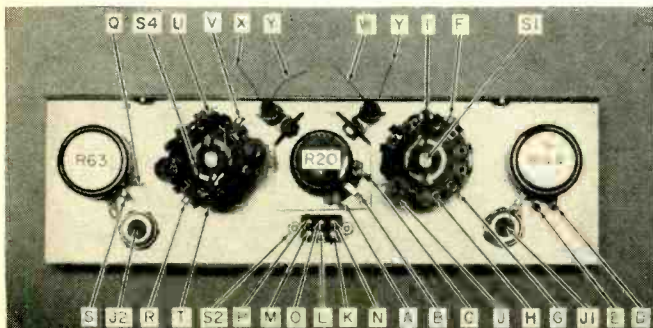

INSIDE THE FRONT PANEL. Letter codes are keyed to the schematics and printed-circuit board diagrams to simplify construction.

tie point. NOTE: Positive side of C28 must go to the insulated terminal. Mount S4 on the front panel and mount the front panel to the bottom with No. 6 screws. Put on the knobs.

Wire the front panel to the printed circuit board. The lettered points on the circuit-board overlay match the lettered points on the front panel photo. The leads connected to J1 and J2 should have a hairpin loop in them. This permits raising the board off the mounting screws to free the bottom of the case for removal for servicing the finished unit. The lead dress of wire "V" which goes to the wiper of S4-a is critical. It should lie parallel with the board just above R57 and then be bent 90° so it goes straight up to the switch. Insulate this wire with sleeving. Splice 7" leads on the lamp leads and insulate the splices with sleeving. Connect the leads of the left lamp to points "W" and "Y" and the right lamp leads to points "X" and "Y". Now start on the rear panel.

Mount J3, J4, J5, and S5 on the rear panel. Mount the power transformer with the primary leads out the side facing up. Install a 1-lug terminal strip (Cinch-Jones 51B) under the right-hand transformer mounting nut. Install the power cord with a strain relief. Connect the white lead and a transformer primary (black) lead to the insulated terminal of the terminal strip. Connect the green safety ground and a transformer secondary (red) lead to the grounded mounting lug of the terminal strip. Mount R18. Then attach the rear panel to the bottom with No. 6 screws. Mount a knob on R18.

Wire the rear panel to the printed circuit board. The numbered points on the rear panel interior photo match the numbered points on the printed circuit board overlay. Connect the black lead in the power cord to one side of the fuse holder. Connect the free transformer primary lead to the power switch S3 (part of R20) on the front panel. Now install the final wire. Install an insulated wire from the other lug on the power switch to the fuse holder.

Check your work. If you are satisfied, put a fuse in the fuse holder, put the heat sinks on Q7 and Q16, and start checkout.

Alignment and checkout

The only adjustments in the unit are switching transient neutralizing capacitor C3 and shaping capacitor C4. These are adjusted to minimize switching transients in the output signal when the input is shorted. To do this, short the input. Feed the tone-burst output to the vertical input of an oscilloscope. Use coax, and terminate it at the scope.

Feed a signal (about 1 MHz) into EXT SYNC IN jack J3 with S5 in the EXT position. Set WIDTH controls for about 5 μsec and PERIOD controls for about 10 μsec. Sync the scope from SYNC OUT jack J4. Adjust PEDESTAL NULL control R18 to eliminate the change in output dc voltage between gate open and gate closed. Adjust C3 and C4 to minimize switching transients in the output. They can be reduced to about 100 mV.

The next thing to check is the centering of TRIGGER LEVEL control R20. Do this by feeding in a sine wave of about 1 to 10 kHz, 5 volts peak-to-peak. Set S5 to INTERNAL and TRIGGER SLOPE to PLUS. Adjust R20 for switching at the 0 volts crossover and note the position of the pointer on the knob. Repeat this with the trigger slope control set to minus. The average position of the pointer should be at 0 on the dial. If it is very far off, you may want to correct it by changing the value of R21. This resistance depends upon the beta of the transistor in IC3-b. (10,000 ohms is about right for units with low betas). Increase the value of R21 if necessary.

The range of adjustment of the WIDTH and PERIOD con-

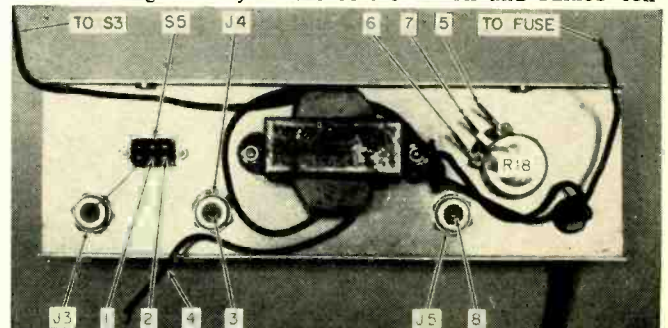

INSIDE THE REAR PANEL. Here too, letter and number codes shown are keyed to the other diagrams to clarify construction details.

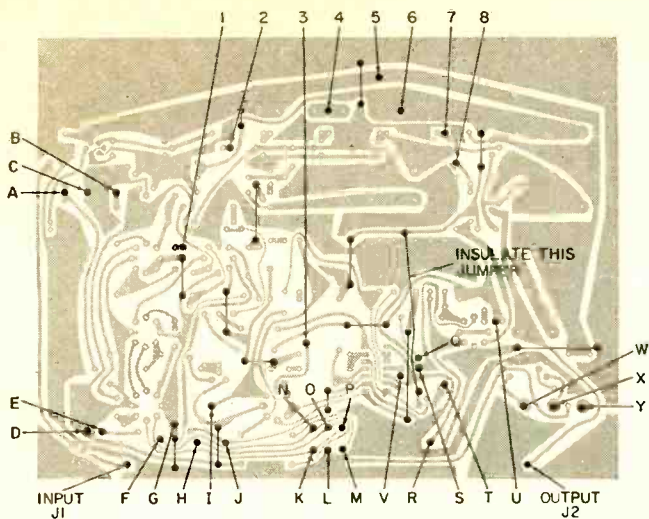

TABLE 1—JUMPERS

A	9" Insulated	M	7/16" Tinned	X	Solder Terminal
B	9" Insulated	N	13/16" Tinned	Y	Solder Terminal
C	9" Insulated	O	13/16" Tinned	J1	1" Tinned
D	1" Tinned	P	13/16" Tinned	J2	3 3/4" Ins.
E	1" Tinned	Q	3" Insulated	1	1" Tinned
F	2" Tinned	R	1" Tinned	2	2 3/4" Insulated
G	1" Tinned	S	3" Insulated	3	5 1/2" Insulated
H	3/4" Tinned	T	3/4" Tinned	4	Solder Terminal
I	2" Tinned	U	2 1/2" Insulated	5	3 1/2" Insulated
J	3/4" Tinned	V	Tinned	6	3 1/2" Insulated
K	7/16" Tinned	W	3" Sleeving	7	3 1/2" Insulated
L	7/16" Tinned		Solder Terminal	8	3 1/2" Insulated

controls should be checked for each position of switches S1 and S4. Do this by feeding in a 1-MHz signal and viewing the output on an oscilloscope. The calibration of these controls is not exact. However, you should have adequate overlap on all ranges. If one range is off, it indicates an off-value capacitor. On S4, the capacitors on the "a" side are the critical ones. **NOTE: When making these checks, make sure the PERIOD controls are set for a longer time than the WIDTH controls.**

The STEADY ON position on the WIDTH control locks the gate open permitting the input to appear at the output. In this mode of operation, all switching and timing is eliminated and no sync pulses are available at J4. Your oscilloscope will have to be synced from this output signal itself. The output should be no less than 5 volts peak-to-peak before clipping starts at 1-kHz input. The input should be greater than the output by no more than 0.5 volt. The green "traffic light" should also be on.

The SINGLE BURST position should turn on the red "traffic light." When J5 is grounded, one burst should appear at the output. The width is dependent upon WIDTH control settings. If the WIDTH controls are set for a long burst, the "traffic lights" will blink; red going off and green coming on for the duration of the burst.

With the output off, residual hum should be about 5 mV peak-to-peak. This hum will have a waveshape resembling a square wave. With the output on and the input shorted, hum will be about 15 to 20 mV peak-to-peak.

The calibration of this unit depends upon the value of the capacitors on S1 and S4-a. They must have the right capaci-

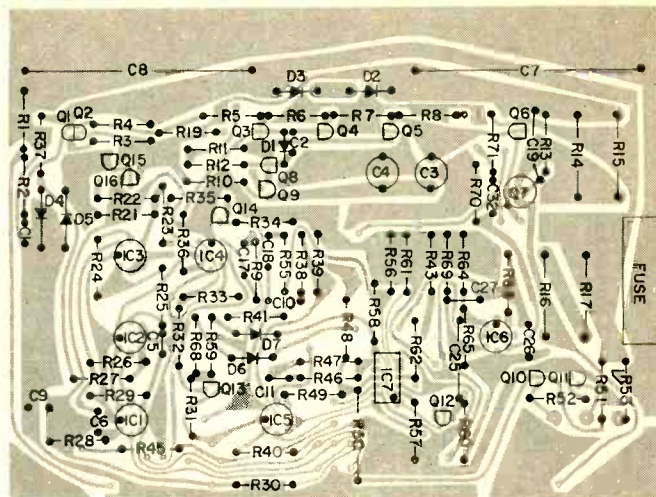

PRINTED-CIRCUIT BOARD DETAILS. Diagram at the top left shows the locations of jumper wires on the circuit board. The table at the left presents jumper details. Above is a diagram of parts positions on the circuit board. Follow it precisely. Below is the circuit board itself, as seen from the foil side. Actual size is 8-inches wide.



tance and they must be physically small to minimize stray capacitance. The 1.0- μ F capacitors are tantalums for very low leakage. Don't use conventional electrolytics. Changing the value of R44 or R63 is another no-no!

The most critical part is the printed circuit board. Parts placement and ground paths have to be just right to prevent stray triggering and parasitic oscillations. Switches and controls purchased from parts houses will have to have the shafts cut to length. For 1/4 inch long bushings, shaft length is 3/8 inch. For 3/8 inch long bushings, shaft length is 3/4 inch. These shaft lengths should be satisfactory for most knobs.

Operating hints

The tone-burst generator adds about 15-mV hum to the gated signal. This is a smaller percentage of 5 volts than of 0.5 volt. For this reason, the tone-burst generator should be run at around 5 volts. Use an attenuator on the output if necessary.

Always terminate the coax cable hooked on the output. The output will work into anything from 50 ohms on up. However, an unterminated coax cable is a very high Q resonant circuit. The fast switching of this unit tends to shock excite unterminated coax. If you must work into unterminated coax or shielded cable, insert a pad (6 or 10 dB) between the output and the unterminated cable.

When setting the PERIOD and WIDTH controls, always have the period greater than the width. No permanent harm will be done if this is not observed; however, the output will not make much sense.

R-E

If You Were the BOSS and Had to CUT BACK, **WOULD YOU FIRE YOU?**

If you were the boss, how would you choose who to let go?

1. You'd probably fire the man who never completed his electronics education. This man may have a solid foundation, but he *quit learning* before he went far enough.
2. You'd probably fire the man who is only a "tinkerer" because his electronics education went *far enough* but *not deep* enough. A specialist must really understand before he can really perform.
3. You'd probably fire the man who has been in electronics for many years but has *not kept up to date* in this rapidly changing industry. Nothing becomes obsolete so quickly as the man who does not study.

Who Will YOUR Boss Fire When He Has To Cut Back? **DON'T BE THE MAN TO GET THE AXE!**

Investigate *now* the Grantham college-level program in electronics engineering, offered (by correspondence) to working technicians while they remain on their jobs. Grantham lessons place heavy stress on fundamental concepts of logic and mathematics (taught so you can understand them), and build from there in a systematic manner, covering physics, circuits, and systems. The lessons are easy to understand because they are carefully written, with step-by-step explanations and consistent review and regrouping of ideas.

Now is the time, not only to protect yourself from unemployment, but also to *prepare yourself for the greater demand in engineering* which is sure to come. You can't become an engineer in a few short weeks; it takes many months. You can be upgrading yourself in your present job while the economy is "slow", and then *be ready to move into engineering* when the national economy gets going again. Yes, now is the time to prepare, so that *you* will be ready to take advantage of opportunity when it presents itself.

Upgrading in your career begins when you begin studying the very first lessons of the Grantham ASEE Degree program in Electronics Engineering. You may very well move up *from* electronics technician to electronics *engineering* technician upon completion of the first 100 lessons (out of a total of 400 in the entire program). Upon completion of the program and receiving your ASEE Degree, you are then ready to work as an *electronics engineer*.

Accreditation and G.I. Bill Approval

Grantham School of Engineering is *accredited* by the Accrediting Commission of the National Home Study, is *approved* under the G.I. Bill, and is *authorized* under the laws of the State of California to grant academic degrees.

Not For Beginners

The Grantham educational program in electronics engineering is *not for beginners*. Every point is explained just as carefully as if you were a beginner, but this program is designed, written, and taught *for* and *to* experienced technicians; beginners are not accepted for enrollment. As a technician, you already know the "hardware" side of electronics, and you can upgrade from technician to engineering technician, and then to engineer, while you continue your employment in electronics.

Grantham School of Engineering

- Established in 1951 •

1505 N. Western Ave.
Hollywood, Calif. 90027

Telephone:
(213) 469-7878

For complete details, mail postcard or coupon.



ELECTRONICS TECHNICIANS:

If you really want
to go places in this
Age of Electronics...

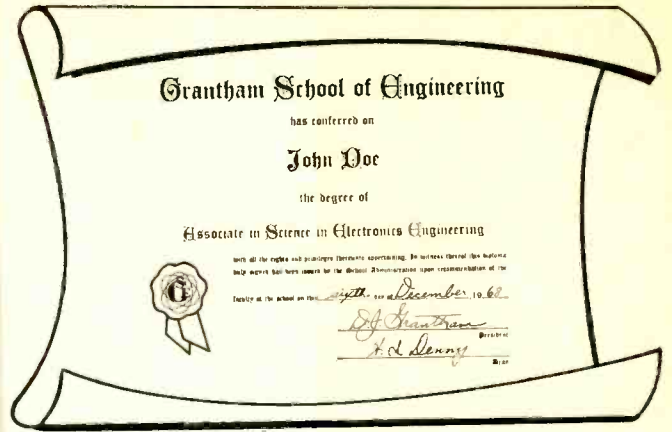

EARN YOUR DEGREE

AND GET INTO ELECTRONICS ENGINEERING!

Advance beyond the technician level. Become an engineer. If you are a high school graduate and have a good aptitude for electronics and mathematics, you can earn the Degree of Associate in Science in Electronics Engineering

MOSTLY BY STUDYING AT HOME

while you remain on your present job. Grantham School of Engineering (GSE) offers a home-study program, followed by a two-week class, for the ASEE Degree. This degree is accredited by the Accrediting Commission of the National Home Study Council.

In this college-level program (presented at the same level as resident-college engineering courses), the lessons have been prepared especially for *home study*. They have been written, revised, added-to, revised, expanded, revised, re-oriented, revised, etc., over a period of many years, by home-study experts in the teaching of engineering, with the one objective of providing a *better way* for technicians to learn engineering.

This *accredited* ASEE Degree program includes a review of basic electronic circuits and systems, a thorough coverage of applied engineering mathematics (including algebra, trigonometry, and calculus), classical and modern physics, technical writing, computer science, electrical networks, and semiconductor circuit analysis and design.

We award the *associate* rather than the bachelor's degree because our educational program covers only engineering and engineering-related subjects and does not cover general subjects such as English, History, Foreign Languages, etc. Notice, however, that the ASEE is a degree in *engineering* rather than the usual junior-college kind of associate degree.

We Teach Better Because We Specialize

The main purpose of the GSE educational program is to *upgrade* electronics technicians to the *engineering level*. Therefore, as a GSE student, you are not, for example,

studying math with accounting students or studying physics with medical students. Instead, all of the lessons covering all subjects are written for students just like yourself — for electronics technicians upgrading to the engineering level. This method allows electronics engineering examples and applications to be tied in with the study of all subjects in the curriculum.

Since all of our students have backgrounds similar to yours and the same professional objective as yours, we can teach all of the required subjects more directly to the point — the way they should be taught (for maximum advantage) specifically to electronics technicians who are upgrading to the engineering level — not generalized to the extent that they apply equally well to a dozen different professions! So *our way* of teaching electronics engineering is more applicable to *your need*.

— G.I. Bill Approved —

For complete details, mail postcard or coupon.

Grantham School of Engineering RE-7-71
1505 N. Western Ave., Hollywood, Calif. 90027

Gentlemen:

I have been in electronics for _____ years. I am interested in the Grantham degree program in Electronics Engineering. Please send me your free bulletin.

Name _____ Age _____

Address _____

City _____ State _____ Zip _____

take it off neat and quick



NEW WIRE STRIPPER-CUTTERS

3 MODELS TO CHOOSE FROM. Made in USA to highest quality standards, these tools cleanly strip and cut all commonly used solid and stranded insulated wire.

Features include adjustable screw stop or unique, patented cam for adaptation to different wire sizes. Self-opening handles have slip ring or thumb-operated catch to keep them closed in tool box. Blades are hardened and ground, cut with a smooth shearing action. Handles have comfortable Cushion Grips.

WRITE FOR DESCRIPTIVE LITERATURE.

nationwide availability through local distributors



XCELITE, INC., 10 Bank St., Orchard Park, N. Y. 14127
In Canada contact Charles W. Pointon, Ltd.
Circle 5 on reader service card

HOME APPLIANCE ELECTRONICS

by JACK DARR
SERVICE EDITOR

ELECTROSTATIC AIR CLEANER

CLEAN AIR HAS BECOME A VERY popular slogan lately. And in many localities, there's no doubt that there is a need for it. Our air is often loaded with particle matter of all shapes, sizes and degrees of toxicity! This contamination must be removed before the air is circulated through the building, whether this is a home or a huge office building.

In the past this has been done by plain old sticky-filters; shallow boxes filled with porous materials, coated with some kind of oil, etc., that catch the dust particles. The efficiency of such a system is fair. However, there is a better way, with electronics.

If a high-intensity electrical charge is put on a particle, by passing it through an electric field, it will then be attracted to any object with an opposite-polarity charge. So if we put a high positive charge on the dust particles by forcing them through a metal grid with a high-voltage charge, they will then be highly attracted to a negatively-charged grid.

They will be precipitated out of the air. Air-cleaners that work on this principle are known as precipitators. In use, the air passes through the two grids, made of thin metal rods, etc. These are mounted very close to either side of a standard filter. Particles are charged as they pass through the first grid and precipitated onto the second.

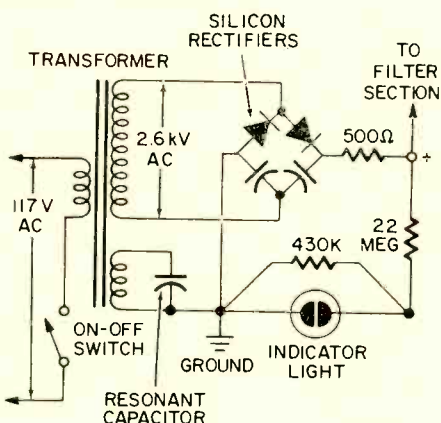

FIG. 1

This makes cleaning simple. Nothing holds the particles to the second grid, except the charge. If it is discharged, the grid can be shaken or tapped lightly and the dust falls off. The grid is then ready for use again. In some of the more elaborate units, periodic discharging and jarring are done automatically so the unit remains at high efficiency at all times.

Circuitry

Once again, here's a plain, standard electronic circuit. A power transformer supplies 2.6 kV ac to a full-wave (symmetrical) voltage-doubler rectifier circuit (see Fig. 1). The doubler capacitors are connected as usual, with the other end of the power transformer secondary to their mid-point. A 500-ohm surge resistor is connected between the high-voltage output, at 5.2 kV and the lines to the filter grids. This protects the rectifiers against accidental shorts between the grids.

A 22-megohm loading resistor is connected from the high-voltage terminal to ground (negative side of the circuit). There is a 430,000-ohm resistor between the ground-end of the big resistor, and the actual ground. The 100-volt drop across this resistor lights a neon indicator lamp. There is no normal current in this circuit, of course. It uses the high electrostatic fields. Current is limited to a 5.0 mA maximum, by a special resonant protection circuit on the power transformer.

It consists of a tertiary winding with a capacitor across it. If the current goes over 5.0 mA, the capacitor and tertiary winding act to over-saturate the core, thus holding the current down. This circuit is used in units made by the Carrier Co.

If the filters become clogged with dust or dirt, so that there is a leakage between the positive and negative grids, the high voltage will drop, and the indicator neon lamp will go out, showing that the unit is no longer working. When the precipitator is turned off, the resistors discharge the high voltage, so the grids can be taken out for cleaning without a shock-hazard to the technician. Even while it is working, the 5.2 kV voltage can give you an annoying bite, but as there is little current, not a dangerous one.

Replacement parts

All electronic parts used are now standard, outside of the power transformer. The rectifiers could be replaced by stock color-TV focus rectifiers, since the applied voltage is well within their ratings. High-voltage capacitors are available in all sizes now. The doublers are tubular types. The resonating capacitor is a bathtub type.



In this unit, the power transformer is a specially-encased type, probably an epoxy case. The case has wells for the doubler capacitors and grooves for the
(continued on page 77)

Kwik-Fix™ picture and waveform charts

© Forest H. Belt & Associates*

SCREEN SYMPTOMS AS GUIDES

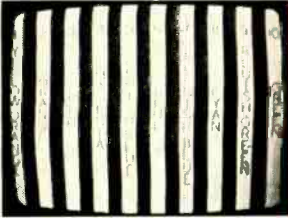
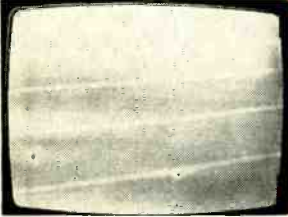
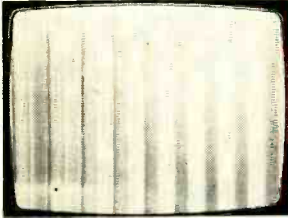
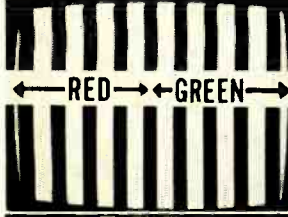
WHERE TO CHECK FIRST

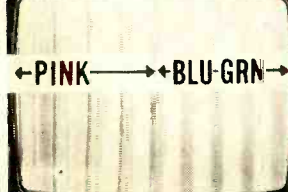
SYMPTOM PIC	DESCRIPTION	VOLTAGE	WAVEFORM	PART
	Normal color bars			
	Screen all blue and out-of-focus; fuzzy retrace lines visible	Q1 collector	WF1	R2, R3
	Screen all blue; bars visible but poorly defined	Q1 collector	WF2	R1, R3
 <p>← RED → ← GREEN →</p>	Blue missing; retrace lines may be visible	only partial help	WF2 WF4	R1, R3, R5, R7, R8
 <p>← ORG → ← R → ← M → ← BLU → ← GRN →</p> <p>E D G</p>	Blue weak; too much green	only partial help	WF3	C1, R5, R6, R7
	No black bars; they're red, on a field of out-of-focus yellow	Q1 base	WF1	C1
 <p>← PINK → ← BLU-GRN →</p>	Colors weak; hues maybe wrong; black bars are bluish; blue retrace lines may be visible	only partial help	WF3	R4, R7

an Easy-Read™ feature by FOREST H. BELT & Associates © 1971

SCREEN SYMPTOMS AS GUIDES

WHERE TO CHECK FIRST

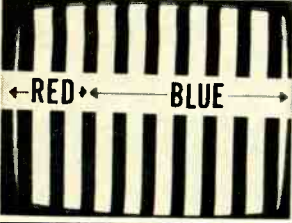
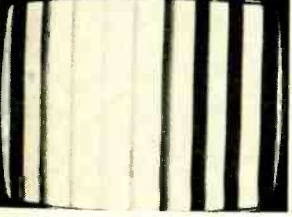
SYMPTOM PIC	DESCRIPTION	VOLTAGE	WAVEFORM	PART
	Green weak	not much help	WF2	R8
	Blues smeared; blue drive control ineffective	only partial help	WF3	R4, R6

NOTES:

Use this guide to help you find which key voltage or waveform to check first.

Feed a keyed rainbow bar signal into the antenna terminals of the receiver.

Study the screen and the action of the HUE, COLOR, and BLUE GAIN controls.

The most helpful clues for the symptom are found at the key test points listed.

Make voltage or waveform checks as suggested.

Use the Voltage Guide and Waveform Guide to analyze the results of those tests.

For a quick check, test or substitute the parts listed as the most likely cause of the symptom.

DC VOLTAGES AS GUIDES

Voltage change	to zero	very low	low	slightly low	slightly high	high
Q1 base Normal 16.3 V	C1 shorted		R1 v. low	R1 low C1 leaky	R3 open	R1 open R2 open, high
Q1 emitter Normal 16 V			R1 v. low	R1 low C1 leaky C1 shorted		R1 open R2 open, high
Q1 collector Normal 160 V		R3 shorted	R1 open R2 open, high R3 low	R1 high R7 open	R4 open R6 shorted R8 open	R1 low R3 open
CRT-cathode pin 11 Normal 190 V		R3 shorted	R1 open R2 open, high R3 low	R7 open	R4 high R8 open	R1 low R3 open

NOTES:

Use this guide and the Waveforms Guide to help you pinpoint the faulty part.

Measure each of the four key voltages with your vtvm or fetvom.

For each voltage, move across to the column that best describes whatever change you can find.

Notice which parts might cause that change.

Finally, notice which parts are repeated in the combination of voltage changes you found.

Test those parts individually for the fault described, or try a substitution.

THE STAGE

This stage, from a 1971-model Zenith transistor/IC color set, is typical of the color output stages in all-transistor chassis. A similar version is used in some imported brands.

The stage charted here is for blue. The red and green are just like it. As you can see from the diagram, all three share coil L1 in common and all three receive Y signal from the same

video connection.

These charts, too, apply to the other two stages. Where a symptom description involves a color, you can just substitute the color of the stage you're interested in.

Waveforms for the red and green stages differ from these for blue. They differ in amplitude and in which "bar" is highest positive (WF1 and WF2) or negative (WF3 and WF4). If you

keep those factors in mind, you can adapt these blue-stage charts for other color output stages.

This stage is not a color-difference amplifier. The input waveform (WF1) is a color-difference signal—blue minus Y. Video or Y signal is added in the emitter circuit. The whole color video signal is developed in the collector output. (In tube color chassis, color-difference is applied to the CRT cathode, while Y signal goes separately to the CRT grid.)

SIGNAL BEHAVIOR

A color-difference preamp precedes this stage. Its signal, the amplified output of the B-Y demodulator, finds a path through R2 to the base of Q1. Resistor R1 is the input load.

C1 and L1 make a trap for 7.16 MHz (twice the 3.58-MHz CW frequency). That's in case the balanced demodulator doesn't cancel the subcarrier perfectly. The effect on color bars if C1 or L1 opens is virtually unnoticeable. You can't tell much difference in waveforms either, unless you watch them while bridging a new C1 or L1 across a defective one.

A video or Y signal is fed to the emitter of the transistor through R8. Similar resistors carry the same video signal to the emitters of the other two color output stages.

With the two signals combined, the transistor amplifies a color-video signal, not color-difference. The mixed signal is boosted in amplitude some 30 dB (about 32 times) in this stage. (Gain may be slightly less in the other stages.)

You can consider R4 the collector output load, although R7 has some bearing. Capacitor C2 and resistor R6 introduce some frequency compensation into the output circuit.

Gray-scale tracking in the color picture depends on the right mixture of all three color video signals. So each color output stage has a gain control. It is R4 in this blue stage. The slider of R4 is set to pick off the right proportion of output color signal and feed it through R5 to the blue cathode of the CRT.

DC DISTRIBUTION

A 250-volt dc line is the chief source of operating voltage for this npn transistor. Supply resistor R7 is the dc path from collector to the 250-volt source. R6 and R4 form an alternate path. If R7 opens up, operating voltage still reaches the collector.

The base of Q1 is biased by R3-R2-R1. Voltage for this divider comes from the junction of R4 and R6, having reached

there through R4-R7 in parallel with R6. R1 and R2 are the ground leg of the divider, with R3 the series part.

The emitter dc path for Q1 is through R8. It includes the video stage (not shown) from which Y signal is brought.

Voltage on the emitter is a few tenths of a volt less positive than on the base. That's forward bias for an npn transistor. The collector, as it should be, is far, far positive with respect to emitter.

SIGNAL AND CONTROL INFLUENCES

Of course, station signal strength can affect waveforms in this stage. But it doesn't bother dc much. Without station signal, only a little bit of blanking gets through the video stages; there's no real Y signal.

For troubleshooting, a rainbow generator is used. The signal it puts out affects the waveforms. Changing the CHROMA SATURATION knob (or whatever it's labeled) on the generator raises or lowers their amplitude in this stage.

For that matter, so does varying the COLOR control on the front panel of the TV receiver. And the HUE control; at hue midrange, the sixth bar of the keyed rainbow waveform should be the most positive (WF1 and WF2) or the most negative (WF3 and WF4).

The BLUE GAIN control in this stage turns the amplitude of output waveform WF4 up and down.

The conditions for waveforms in these charts are this: Rf signal from rainbow color-bar generator strong enough that the receiver agc eliminates snow. COLOR SATURATION control on generator slightly above 100%. COLOR control on receiver about two-thirds up; HUE control centered.

QUICK TROUBLESHOOTING

Waveforms probably prove more than dc voltages do. Just make sure the two input signals are applied. Then check WF2 and WF3.

The defect may be fairly obvious if a waveform is missing. What's much more tricky are the subtleties of waveform symptoms. Study the waveforms in the chart carefully. Phase shift is an important clue. Watch which waveform bars point furthest in one direction or the other. Count them from the sync pulse (blanking).

As already hinted, the best way to see if either of the components in the 7.16-MHz trap (C1-L1) is open is substitution. The same is true for C2. (Waveforms on following pages)

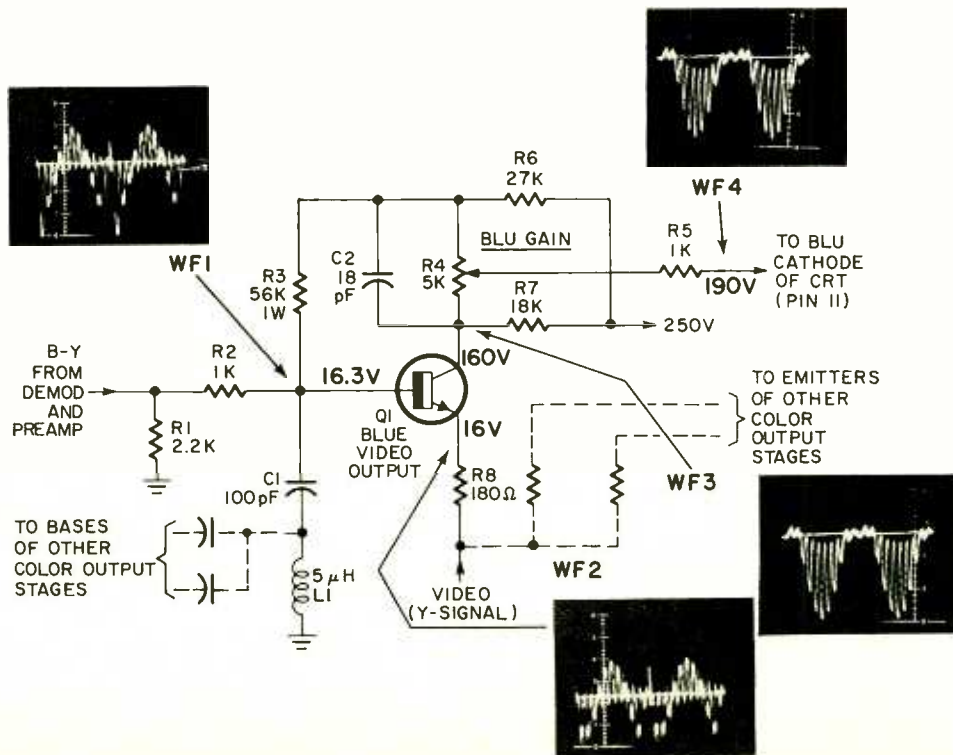

WAVEFORMS AS GUIDES

V p-p low V p-p high V p-p zero Changed Shapes

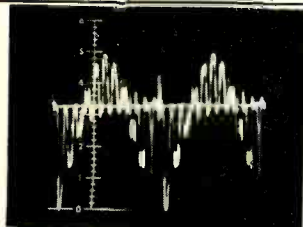

WF1 Normal 5.0 V p-p

This input waveform is taken at the base of Q1. It's a color-difference signal. It is what's recovered in the B-Y demodulator when a keyed rainbow signal is fed to the color receiver. The waveform in this chart was preamplified by some stages inside an IC. The most important characteristic is phase, which is easily evaluated. If phase is proper, the sixth pulse (bar) has the highest positive-going amplitude.

R1 low
R2 high
R8 low

R3 open
R4 open
R6 shorted
R8 open

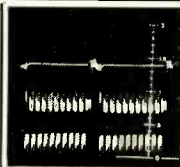

1.5 V p-p
R1 open

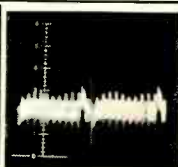

0.4 V p-p
R2 open

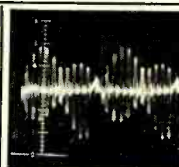

0.6 V p-p
C1 shorted

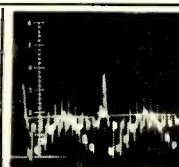

4.0 V p-p
R3 low

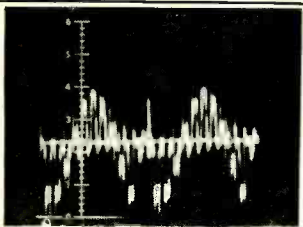

WF2 Normal 4.0 V p-p

Taken at the emitter of the transistor, this waveform combines the blue color-difference signal of WF1 with a video (Y) signal from the video amps of the set. Adding video does change the appearance of the bars—they look over-peaked, for one thing. The amplitude ratio between bars and blanking pulse is changed, too. The sixth bar remains the highest positive one. There is a slight amplitude loss from the base to the emitter.

R2 high

R6 shorted
R8 high

R3 shorted

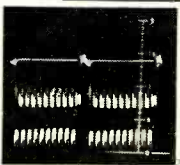

1.5 V p-p
R1 open

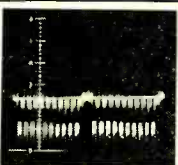

3.0 V p-p
R1 low

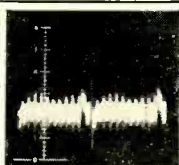

0.4 V p-p
R2 open

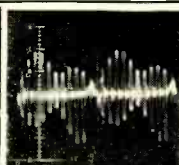

0.6 V p-p
C1 shorted

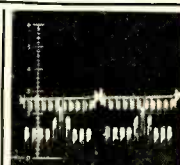

3.0 V p-p
R3 open

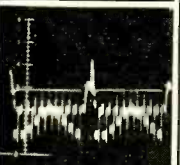

4.0 V p-p
R3 low

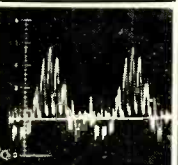

5.0 V p-p
R4 open

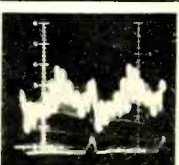

4.0 V p-p
R8 open

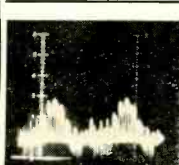

3.0 V p-p
R7 open

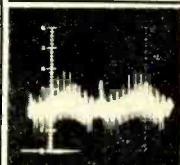

3.0 V p-p
R8 shorted

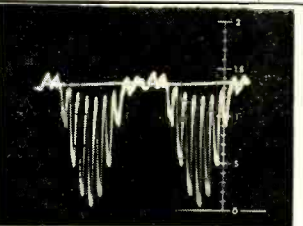

WF3 Normal 150 V p-p

Taken at the collector, this waveform is the blue color signal after Y has been added and the combination amplified about 30 times. Polarity is reversed through normal action of a common-emitter amplifier; the sixth bar now has the highest negative amplitude. The parabolic downward bowing of the "zero average" line through the waveform is from the brightness (Y) component that has been added from the video stages. The Y component is not part of the color-difference (B-Y) signal recovered by the demodulator.

R1 low

R2 open
R8 open

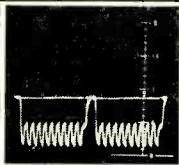

70 V p-p
R1 open

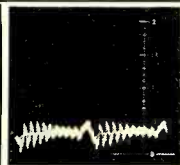

5 V p-p
R1 low
C1 shorted

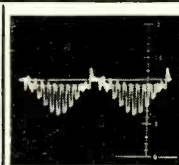

70 V p-p
R2 high

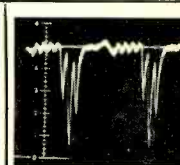

50 V p-p
R3 open



220 V p-p
R4 open

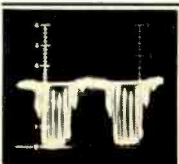

300 V p-p
R4 open



120 V p-p
R6 open
R7 open

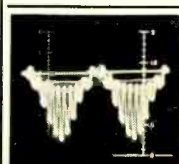

120 V p-p
R6 shorted

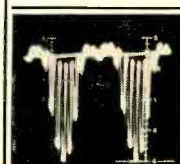

200 V p-p
R8 low

WAVEFORMS AS GUIDES

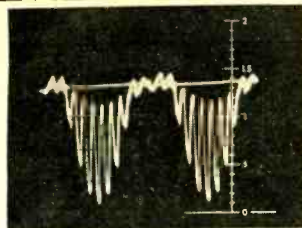

WF4 Normal 150 V p-p

This is the output waveform of this blue video output stage. It is what's fed to the blue cathode of the CRT (pin 11). Amplitude is slightly variable with R4. The difference between this blue output and the output from the red and green output stages is phase and amplitude. Red video output amplitude is usually only 80% as much as blue, and its third bar is the "tallest" negative one. Green waveform is only about 35% the size of blue—about 50 volts p-p in this chassis; its ninth and tenth bars are tallest. This waveform is a duplicate of WF3. The symptom photos for WF3 apply to WF4.

V p-p low R1 low R5 low		V p-p zero R2 open R5 open R4 open				
--------------------------------------	--	--	--	--	--	--

Use this guide and the Voltages Guide to help you pin down fault possibilities.

Feed a keyed rainbow bar signal into the antenna terminals of the color set. Set the generator COLOR knob above 100%. Turn the receiver COLOR knob two-thirds up and the HUE knob to midposition.

Use the direct probe of your scope. Set the scope sweep for

7875 Hz, to display two full cycles of each signal. External sync works best, with the lead draped or clipped near the horizontal output stage.

Check the four waveforms at the four key test points. Note amplitude. If one is low or high, check the parts listed under those columns.

Note waveshape, particularly positions of the bars. If there's a change that matches one shown, check the parts indicated.

Don't Throw Good Power Diodes Away

by **J. COLT**

Been throwing away those power transistors that turn up bad in home projects or in equipment coming into the shop? If you have, here's betting you'll think twice before you junk those 3-15-amp (or higher) jobs from now on.

The next time you run across an obvious clunker, use an ohmmeter to check which junctions are still good. The more desirable junction to have intact is the collector-base. This is because most power transistors in use today have the collector physically connected to the case for ease of heat dissipation. If the emitter-base junction happens to be the good one, you still have a usable diode, but you won't be able to get rid of internally generated heat as easily.

By the way, all the rules of the power-transistor mounting game still apply. It is a good idea, therefore, to salvage mounting hardware along with the transistor when you can.

As to the reverse voltage rating of your new-found diode, use the BV_{ceo} rating when utilizing the collector-base junction, and the reverse breakdown rating of the emitter-base when operating with that junction. The breakdown rating of the emitter-base junction for silicon transistors is usually fairly low, typically 5 to 10 volts.

Fig. 1 gives a comparison of I-V characteristics for a silicon power diode and a germanium power transis-

tor using its collector-base junction as a diode. Obviously, and particularly at lower currents, the power transistor makes a more efficient rectifier because of lower voltage drop.

It is safe to say that all germanium power transistors you use will be of the pnp type, while most of the silicon transistors will be of the npn variety. Fig. 2 shows how these different

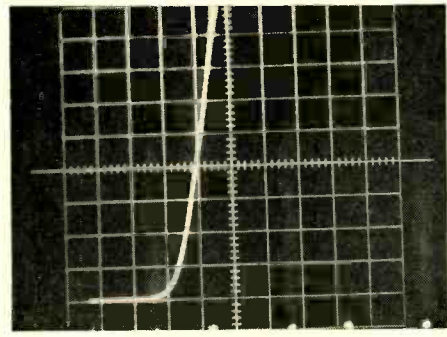

SILICON DIODE

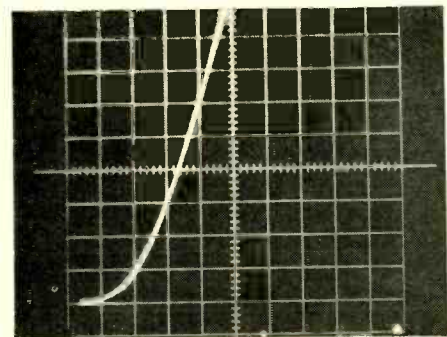

GERMANIUM TRANSISTOR

Fig. 1

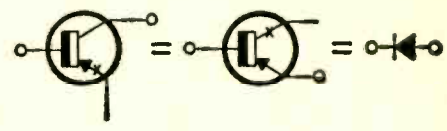

PNP TRANSISTORS

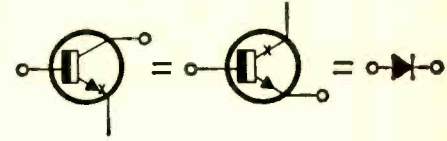

NPN TRANSISTORS

Fig. 2

transistors compare electrically with a diode for the two differing bad-junction cases.

You won't gain much in efficiency by using a silicon transistor as a diode, because the bulk resistance of silicon is higher than that of germanium. However, if you're in need of a power diode and the only thing available is a silicon transistor, it'll make a mighty good diode.

The only drawback in using power transistors as diodes is their relatively low breakdown voltages—although some silicon transistors these days have BV_{ceo} 's on the order of 250-400 volts. You can, however, hook up a mighty efficient low-voltage, high-current power supply using otherwise bad transistor. And, considering the fact that you were going to throw the transistors away, at a rectifier cost of zero. It would be cheap at twice the price.

R-E



24 easy-to-build burglar alarms

Five more burglar-alarm circuits you'll want to breadboard and use. They're not all simple, but they are effective

by R. M. MARSTON

TO MAKE A BURGLAR ALARM FOOLPROOF IS probably impossible. But there are ways to make it more difficult to crack. Self-latching and delayed-latching circuitry are two steps in that direction. These additions to last month's basic circuits are presented here.

Various degrees of sophistication can be added to the basic alarm circuits. The most important of these is known as the "delayed self-latching facility." In the alarm circuits that we've looked at so far, the alarm sounds as soon as any input switch is operated. As a result, if the owner turns the alarm system on while inside a protected building, it is impossible for him to leave that building without triggering the alarm. This is overcome by the delayed self-latching facility, which insures that the alarm system does not go into the self-latching mode until some fixed time (variable between 10 seconds and 2 minutes) after the system is initially put into the "standby" condition.

Figure 10 shows a practical example of a delayed-latching circuit connected to a simple alarm system of the type shown in Fig. 6. Here, C2 and R5-R6 are connected as a time-controlled voltage divider, with the C2-R5 junction taken to the base of emitter follower Q2. The emitter current of Q2 is fed into the base of common-emitter amplifier Q1 via R3, and Q1 collector is taken to the positive supply line via the SCR's latching resistor, R2. The R2-Q1 collector junction is taken to the SCR anode via D2. Fig. 9 is a tamperproof version of Fig. 8 (last month).

Now, when the supply is initially connected to the circuit (by throwing S4 to the **STANDBY** position) C2 is fully discharged. At this instant Q2 base is effectively shorted to the positive supply, and Q1 is driven to saturation by the resulting emitter current of Q2. Since Q1 is saturated under this condition, the Q1-collector end of R2 is virtually shorted

to the zero volts (ground) line. Consequently, if any of the input alarm switches (S1 to S3) are opened at this stage, the SCR operates and sounds the alarm. But the SCR will not self-latch, since all of the available latching current of R2 is taken by the collector of Q1, and none is left over to flow into the SCR anode.

As soon as S4 is thrown into the **STANDBY** position, C2 starts to charge exponentially via R5 and R6, and the voltages on the base and emitter of Q2 start to decay slowly towards zero. After a period of between ten seconds and two minutes (depending on the setting of R5), the emitter current of Q2 falls to such a low value that Q1 comes out of saturation and, eventually, turns off. Q1 then draws zero collector current from latching resistor R2. Thus, if any of the alarm switches are opened at or after this stage, the SCR and alarm will turn on and self-latch, since a latching current then flows into the SCR anode via R2 and D2.

Thus, the delayed-latching circuit enables the owner to turn the alarm system on to standby from within a protected building, and then to leave that building via a protected door. As the owner passes through the protected doorway, the alarm will sound, indicating that the system is operative, but the alarm will turn off as soon as the owner closes and locks the door behind him. A short time later, the alarm system automatically sets itself into the self-latching model. Now if any of the input alarm switches are opened, the alarm switches are opened, the alarm will operate and self-latch in the normal way.

The delayed-latching unit draws a typical standby current of only 5 μ A (in addition to the normal alarm circuit current) when set in the normal standby mode, and thus places negligible drain on supply batteries.

When constructing this circuit,

make sure that C2 is a reasonably low-leakage type (most low-voltage electrolytics will perform adequately). To check this, set R5 to its maximum value, place a voltmeter across R2, and then check that the voltmeter reading falls to zero after a couple of minutes, i.e., once C2 is fully charged.

The charge time can be reduced, if required, by placing a short across R5, but this short must be removed when the final voltmeter reading is taken. In the circuit, D2 and D3 can be any general-purpose silicon diodes. D3 prevents supply line transients from causing the circuit to unlatch itself when the alarm is operating. R7 is used to rapidly discharge (and thus reset) C2 when S4 is moved to the **OFF/RESET** position, and is a half-watt resistor.

Another useful circuit that can be used in conjunction with a normal alarm system is the "automatic turn-off" facility. It makes a self-latching alarm automatically unlatch some time after it is initially triggered, so the alarm sounds for only a limited period. Figure 11 shows a practical circuit of this type, connected to a simple "close-to-operate" alarm.

The auto turn-off circuit works in a similar way to the delayed self-latching circuit of Fig. 10. C1 and R5-R6 are wired as a time-controlled voltage divider, that is connected to the base of emitter follower Q2. Q2 emitter current feeds directly into the base of common-emitter amplifier Q1, which uses latching resistor R3 as its collector load. Normally, the SCR is off, so zero voltage is developed across the auto turn-off circuit, which is thus inoperative. C1 is fully discharged under this condition.

When any of the alarm input switches (S1 to S_n) are momentarily operated, the SCR is driven on in the normal way and the alarm starts to operate. The SCR saturates under this condition, so a supply voltage appears across the auto turn-off circuit. At this instant C1

9.

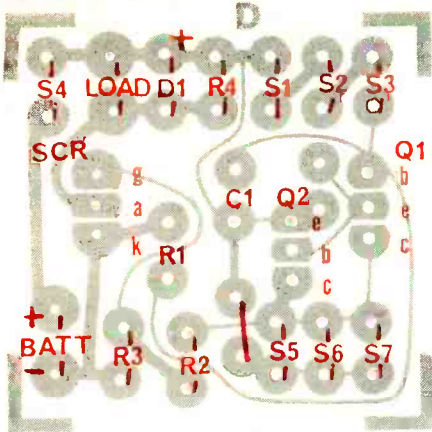

PARTS LIST

- R1—4.7 megohms, 1/2 watt
- R2, R3—1000 ohms, 1/2 watt
- R4—470 ohms

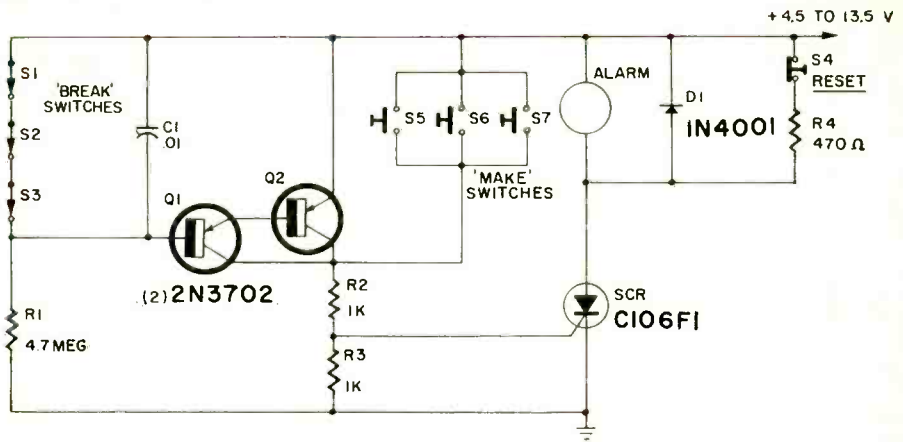

- C1—.01-μF ceramic
- D1—1N4001
- Q1, Q2—2N3702
- SCR—C106F1
- S1, S2, S3—spst normally closed
- S4—spst normally closed

- S5, S6, S7—spst normally open
- Alarm device
- Circuit board D
- For non-interrupting alarms switch S4 should be moved and inserted in the battery-supply line as indicated in the circuit board diagram.

10.

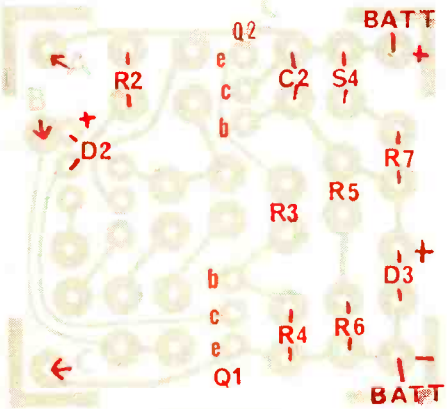

PARTS LIST

- R1—12,000 ohms, 1/2 watt
- R2—470 ohms, 1/2 watt
- R3—3300 ohms, 1/2 watt
- R4—10,000 ohms, 1/2 watt
- R5—potentiometer, 500,000 ohms
- R6—33,000 ohms, 1/2 watt
- R7—47 ohms, 1/2 watt

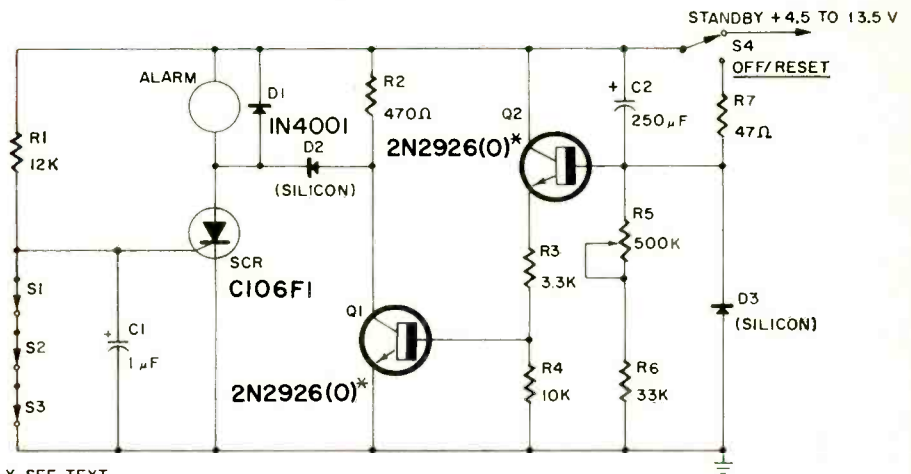

- * SEE TEXT
- C1—1 μF, 25 V
- C2—250 μF, 25 V
- D1, D2, D3—1N4001
- Q1, Q2—2N2926(O)*
- SCR—C106F1
- S1, S2, S3—normally closed spst
- S4—spdt

- Alarm device
- Circuit boards D and A
- Points A, B, C on circuit board D (at left) connect to circuit board A as set up in circuit 6 (last month's article) Point A connects to the cathode of D1; point B to the anode of D1, Point C to the ground.

11.

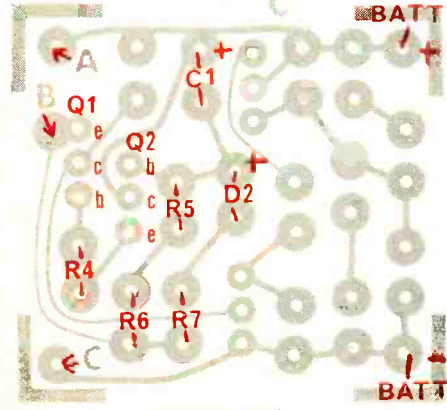

PARTS LIST

- R1, R2—1000 ohms, 1/2 watt
- R3—470 ohms, 1/2 watt
- R4—3300 ohms, 1/2 watt
- R5—potentiometer, 500,000 ohms
- R6—33,000 ohms, 1/2 watt
- R7—120 ohms
- C1—250 μF, 25 V
- D1, D2—1N4001

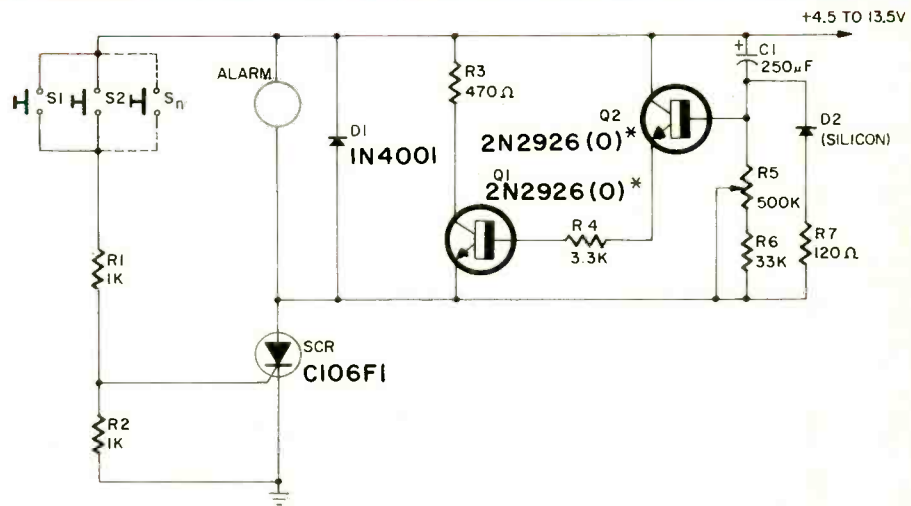

- * SEE TEXT
- Q1, Q2—2N2926(O)*
- SCR—C106F1
- S1, S2, S_n—spst normally open
- Alarm device
- Circuit boards C and A

- Points A, B and C on circuit board C (at left) connect to circuit board A as set up in circuit 5 (last month's article). Point A connects to the cathode of D1; point B to the anode of D1; point C to ground.

12.

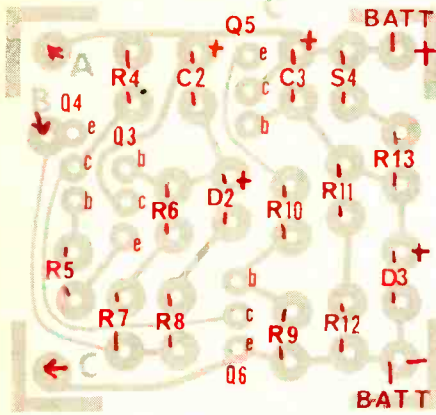

PARTS LIST

- R1—4.7 megohms, 1/2 watt
- R2, R3—1000 ohms, 1/2 watt
- R4—470 ohms, 1/2 watt
- R5, R10—3300 ohms, 1/2 watt
- R6, R11—potentiometer, 500,000 ohms
- R7, R12—33,000 ohms, 1/2 watt
- R8—120 ohms, 1/2 watt
- R9—10,000 ohms, 1/2 watt
- R13—47 ohms, 1/2 watt
- C1—.01-μf ceramic
- C2, C3—250 μF, 25 V

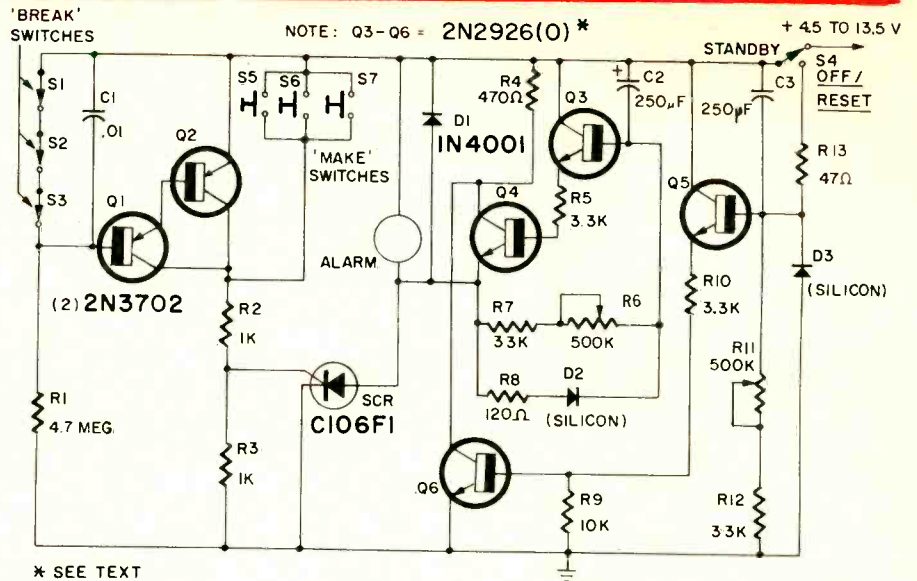

* SEE TEXT

- D1, D2, D3—IN4001
- Q1, Q2—2N3702
- Q3, Q4, Q5, Q6—2N2926 (0)
- SCR—C106F1
- S1, S2, S3—spst normally closed
- S4—spdt
- S5, S6, S7—spst normally open

Alarm device
Circuit boards C and D
Points A, B and C on circuit board C (at left) connect to circuit board D as set up in circuit 9 of this article. Point A connects to the cathode of D1; point B to the anode of D1; point C to ground.

13.

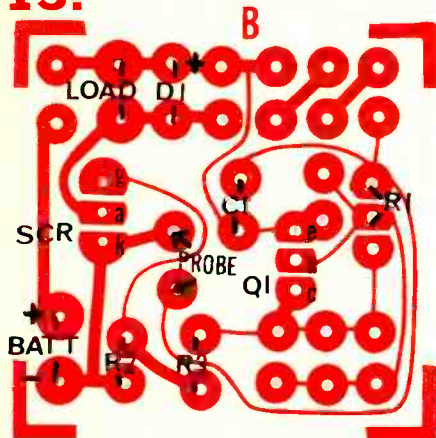

PARTS LIST

- R1—3300 ohms, 1/2 watt
- R2—220 ohms, 1/2 watt
- R3—1000 ohms, 1/2 watt
- C1—.05-μf ceramic
- D1—IN4001
- Q1—2N3702
- SCR—C106F1
- Alarm device
- Metal probes
- Circuit board B

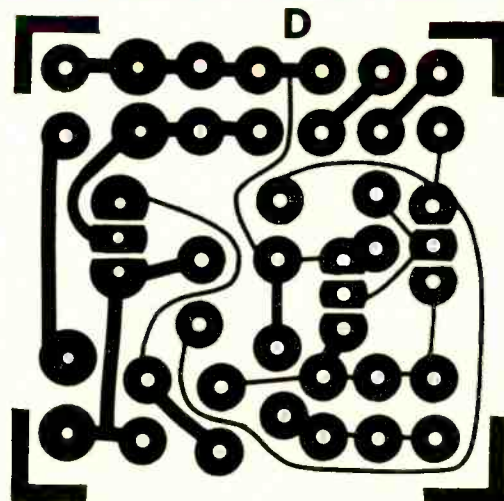
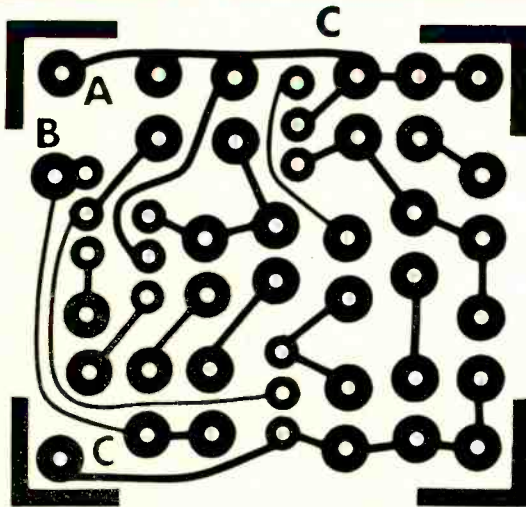
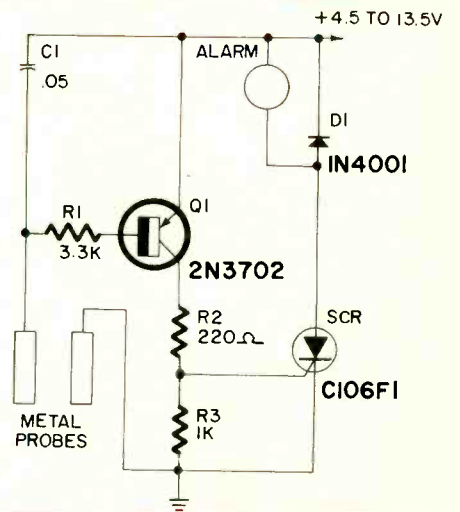

FULL-SIZE CIRCUIT BOARD patterns for boards C and D. Use these patterns to make your boards

The following parts are available from Photolum Corp., 118 E. 28 St., N. Y. N. Y. 10016

Kit RE671-PC consisting of 1-panel of 4 alarm circuit boards; 1-panel of 3 com-

ponent mounting strips; 100 plug-in connectors . . . \$6.25, postpaid.

Kit RE671-T consisting of 1 SCR; 1 diode; 4 Transistors (2 npn, 2 pnp) and 1 photo cell . . . \$3.75, postpaid.

is fully discharged, so the base of Q1 is effectively shorted to the positive supply line. A heavy current thus flows into Q1 base via Q2, and Q1 is thus driven to saturation. The Q1 saturation current is limited by latching resistor R3, and flows directly into the anode of the SCR. Consequently, this current causes the alarm to self-latch as soon as an input switch is initially operated.

As soon as the SCR self-latches, C1 starts to charge exponentially via R5 and R6, and the Q2 emitter current starts to decay slowly towards zero. After a period of between ten seconds and two minutes (depending on the setting of R5), this current falls to such a low value that Q1 starts to turn off, and the R3 current falls below the holding current of the SCR. At this stage, therefore, the SCR automatically unlatches, and the alarm turns off (assuming that the alarm input switch is no longer being operated at this time). As soon as the SCR turns off, the supply is automatically removed from the auto turn-off circuit, and C1 then rapidly discharges via the alarm and R7-D2. The circuit is then ready to operate again the next time one of the input switches is activated. The automatic turn-off circuit draws zero current when it is in the normal (standby) condition, since any current that it does draw must flow to ground through the SCR anode, and the SCR is always blocked when the alarm is in the standby mode.

The automatic turn-off circuit of Fig. 11 is shown connected to a simple "make-to-operate" alarm of the type in Fig. 5 (last month). It can be used equally well with any of the other alarm circuits shown in this article. It can, if required, be combined with the delayed self-latching circuit of Fig. 10, by using the connections shown in Fig. 12. This circuit is a high-performance burglar alarm that can be operated by either "make" or "break" input switches, and has both delayed self-latching and automatic turn-off facilities. The circuit draws a typical standby current of only 5 μ A, and thus places a negligible drain on the supply batteries.

In this circuit, R4 is the self-latching resistor, and the auto turn-off circuit is made up of Q3, Q4, R5, R6, R7, R8, D2 and C2. The delayed self-latching circuit is made up of Q5, Q6, R1, R10, R11, R12, R13, D3 and C3; Q4 replaces D2 of the basic delayed self-latching circuit of Fig. 10. The circuits give maximum delays of about 2 minutes. These periods can be increased, if required, by increasing the values of electrolytic capacitors C2 or C3. These capacitors must, however, be low-leakage types.

The transistors used in this and the earlier circuits are Texas 2N3702 pnp types, and General Electric 2N2926 (orange) npn types; it should be noted that the specified 2N2926 transistors are gain-coded in orange, as indicated by the (O) suffix in the type number. This indicates a h_{FE} range of 90-180. The diagram on this page shows the lead connections.

All of the circuits that we have looked at so far are outstandingly useful

and versatile, particularly when used as burglar alarms. The following list suggests some of the many different ways in which they can be used as protection devices in the home and in industry.

1. **Normally-open** or normally-closed Microswitches or reed-and-magnet switches can be connected to doors, etc., so that the alarm sounds whenever a door, window, drawer, or hatch is opened.

2. **Pressure switches** can be placed under rugs or carpets, so that an alarm sounds if an intruder steps on a protected area.

3. **Mercury or trembler switches** can be fixed to the back of paintings or other works of art, so that the alarm sounds as soon as the object is tilted or moved.

4. **A lattice of fine fuse wire** can be series-connected and drawn tight across window glass, etc., and used as a break-to-operate switch, so that the alarm sounds if the glass (and thus the wire) is broken.

5. **A lattice of insulated wire**, series-connected, can be bonded to ceilings, etc., and used as a break-to-operate switch, so that the alarm sounds if the intruder tries to enter a building by cutting through ceilings, walls, or floor.

6. **Push-button switches** can be installed in bedrooms, etc., so that the alarm can be remotely operated if an intruder is heard in the protected building.

7. **Thermostatic switches** can be connected to the alarm, so that the alarm sounds automatically in the event of a fire.

2N3702 and 2N2926(O) transistors that are used in the projects to be described; note that the specified 2N2926 transistors are gain-coded in orange, as indicated by the (O) suffix in the type number.



BASING ARRANGEMENTS for the transistors and SCR used in the alarms in this article.

Water and steam operated alarms

All of the alarm projects shown in the previous article relied for their operation on the resistance of a pair of contacts changing from near-zero (switch closed) to near-infinity (switch open), or vice versa. A development of this type of circuit is that in which the contact resistance switches from a high to a low value, but does not necessarily fall to near-zero. The best known circuit of this latter type is the water-operated alarm, in which the resistance across a pair of metal probes falls abruptly from a high value to a moderately low one when water or some other conductive liquid comes into contact with the probes. Fig. 13 shows a practical circuit of this type.

Here, the SCR is wired in the non-latching mode, and has its gate current derived from voltage divider R2-R3 in the collector circuit of common emitter amplifier Q1. The SCR turns on only

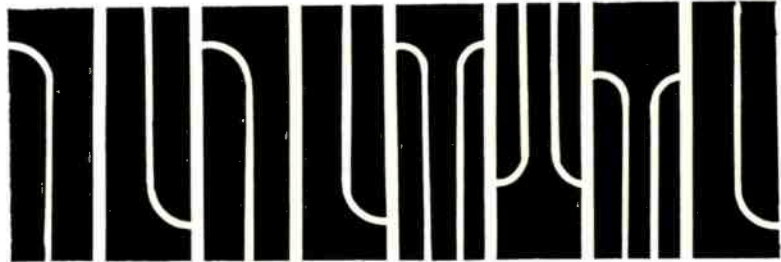

COMPONENT MOUNTING STRIP. Each strip contains 3 sections for diodes, capacitors or resistors, 1 transistor section and 1 SCR section.

So far in this series of articles we have shown how the sensitive C106F1 silicon controlled rectifier (SCR) could be used as the basis of a number of electronic alarm systems, and gave the practical circuits of nine contact-operated alarm projects. In this article we go on to show a further fifteen alarm projects that can be built around the C106F1. These projects include alarms triggered by light-beam, smoke, fire, over-temperature, frost, under-temperature, and by contact with water or steam.

In these projects, the actual alarm device can be any low-voltage (3-12 volts) self-interrupting bell, buzzer, or siren that draws an operating current less than 2 amps. The alarm circuits should be operated from supplies roughly 1.5 volts greater than the normal operating voltage of the alarm device used. The diagram shows lead connections of the C106F1, and the

when the Q1 collector current exceeds 1 mA or so. The base current of Q1 is derived from ground via R1 and the effective resistance between the metal probes. Normally, a near-infinite resistance appears between these probes, so negligible base current flows in Q1. Only a small leakage-current thus flows in the collector of Q1, and the SCR and alarm are therefore off under this condition.

When a resistance is connected across the metal probes, a current flows in Q1 base, and an amplified version of this current appears at Q1 collector. If the probe resistance is reduced to a value of roughly 220,000 ohms or less, sufficient current flows in Q1's collector to turn the SCR on. The alarm thus operates whenever a resistance of less than 220,000 ohms is placed across the metal probes.

For more alarm circuits join us next issue where this article continues. **R-E**

ELECTRONICS HELIX

by JAMES R. KIMSEY

This helix is a fun puzzle. The definitions are keyed to the numbered puzzle boxes. The last letter of each word is the first letter of the next. Try your skill at following this square circle to its center. If you get stuck, you'll find the right answers on page 77.

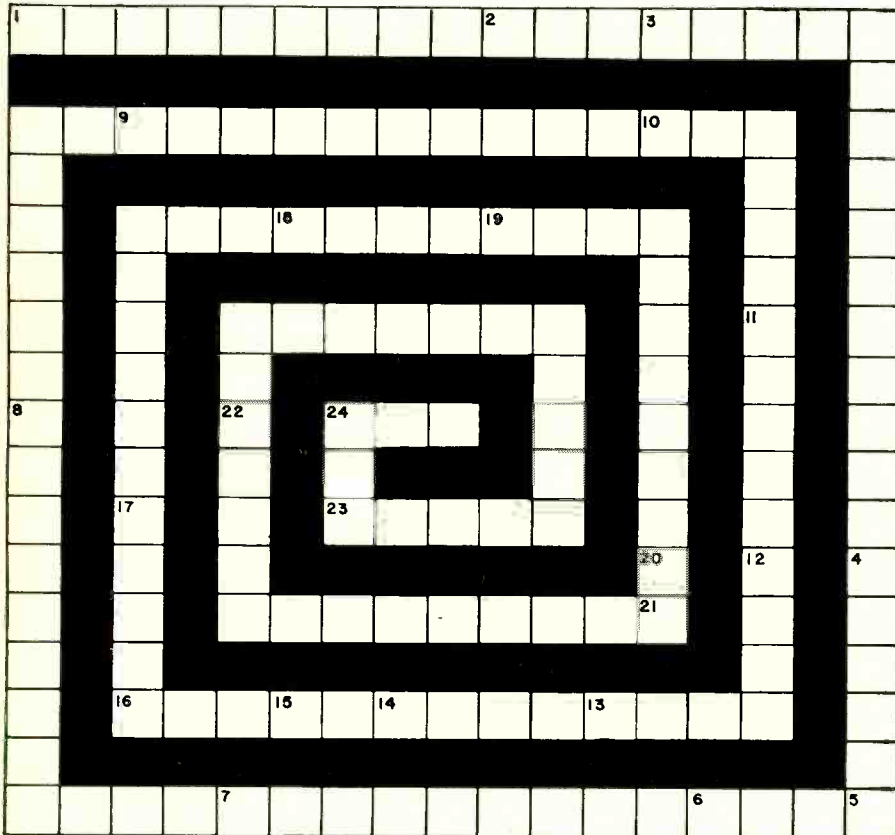

- | | | | |
|----|--|----|---|
| 1 | One joule. | 12 | Aerial. |
| 2 | Mechanical device for indicating on scale value to which pointer or knob is set. | 13 | Smallest units of any chemical element. |
| 3 | Family of plane curves described by point having two simple harmonic motions at right angles, various phase relations and integral frequency ratios. | 14 | Single sideband (abbr.). |
| 4 | Mechanical device for completing, interrupting or changing a circuit connection. | 15 | Range of frequencies. |
| 5 | Certain kind of electrical noise often caused by vibrators. | 16 | Component of two elements— anode and cathode. |
| 6 | Synonym for beat. | 17 | Device that supplies current and voltages normally obtained from batteries which device replaces. |
| 7 | Coil of wire, usually on an iron core, which produces strong magnetic field when current is sent through it. | 18 | Proportion. |
| 8 | Fittings for making electrical connections. | 19 | Recorder trace or permanent record produced by oscillograph. |
| 9 | Type of mounting and feed used to move cutting head at uniform rate across recording disc in some inexpensive disc recorders (2 wds). | 20 | Millivolt (abbr.). |
| 10 | CGS electromagnetic unit of magnetic flux. | 21 | In TV, downward movement of scanning beam from top to bottom of picture being televised (2 wds). |
| 11 | Name of Greek letter used to designate wavelength measured in meters or fractions thereof. | 22 | General term applying to any cell whose electrical properties are affected by illumination (2 wds). |
| | | 23 | Small strip of metal placed on terminal screw or riveted to insulating material to provide convenient means for making soldered connection. |
| | | 24 | Portion of magnetic circuit in which there is no ferromagnetic material; distance between poles. |

SERVICE NOTES

HEATHKIT FM-3 AND FM-3A TUNERS

One service complaint that has shown up as these units have become older is a sudden major reduction in volume while the tuner is playing or perhaps it will not come on to full level for a long time after it is switched on.

On those units having a severe drift problem which has not been cured by the addition of an afc modification, this symptom may at first be mistaken for "drift." In most cases, however, it can be traced to a breakdown of the fixed capacitors located inside the i.f. and discriminator cans. This seems most likely to occur if the tuner has been located in a dusty atmosphere.

The remedy is just to demount the three cans and replace the 5 capacitors with mica units. It is recommended that all five be changed at the same time in order to avoid call-backs. Be sure to bend up and cut off both overlapping metal strips (separated by the mica dielectric) which form the built-in capacitors, otherwise tuning may not be possible.

Measurements taken on transformers from several operating FM-3A's disclosed that the 4 capacitors across the primary and secondaries of the two i.f. transformers each measured 90 pF while the one across the discriminator secondary was 40 pF. Values of 82 pF and 39 pF respectively were substituted and resulted in adequate range on the slugs for tuning purposes.—G. Neal

DRIFTING CAPACITORS

Here are two methods that help you spot a drifting capacitor, in vertical or horizontal circuits. Put a large pointer knob on the hold control, then carefully mark the upper and lower limits of hold control range when set is first turned on.

Heat the suspected capacitor with the solder gun noting any changes in hold range. If any definite change has occurred, reverse these tactics and blow a jet of cold air onto the capacitor through a piece of plastic tubing. If you're working on the culprit, you'll soon notice the area of hold returning to your cold set markings.

The knob idea is also good to check the hot and cold ranges with set operating under normal self-heat conditions. You can mount a piece of cardboard to provide a panel on which to make the markings. This kink takes the guesswork out of knowing the exact range of hold.—H. Josephs

R-E

Design for STEREO

by MANNIE HOROWITZ*

how to design your own solid-state audio amplifier

Determining bias and stability parameters for small-signal amplifier stages

THE ULTIMATE GOAL OF AN AUDIO AMPLIFIER is to provide gain for the input signal. However important the bias and stability considerations are, a circuit must be designed so the amplifier stage furnishes voltage, current and/or power amplification. At the output, the signal delivered to a load should be an enlarged and unadulterated replica of the input.

The three most commonly used transistor circuits are the common base, common emitter and common collector arrangements. The important information we must have about a circuit built around each of these arrangements consists of the current, voltage and power gains and the input and output impedances.

These factors can be determined by plotting the appropriate circuit information on collector characteristic curves. Procedures of this type are quite accurate for any one transistor, but are cumbersome.

Small-signal amplifiers are more readily analyzed using equivalent circuits. These circuits involve the semiconductor device and the associated components. Two different equivalent circuits are widely used—the *hybrid equivalent* and the *equivalent-T*. Both circuits have been previously exploited, although they may not have been recognized as such in the text. We will briefly discuss the hybrid equivalent as some important parameters are based on this method of analysis. Greater emphasis will be placed on the T-equivalent circuit as low-frequency design requirements are easily satisfied using these procedures. Relationships will be established between the two sets of parameters.

Hybrid equivalent circuit

The hybrid model of the circuit assumes the transistor, in any configuration, has a pair of input terminals and a pair of output terminals. In Fig. 1, the input voltage and current fed to the transistor are V_1 and I_1 respectively. After amplification, the output current, I_2 , flows through load resistor R_C , developing a voltage V_2 across this load. Four important



FIG. 1—HYBRID PARAMETERS are developed with this circuit. R_C is collector resistor in the transistor circuit.

*Chief Project Engineer, EICO Electronics Instrument Co. Inc.

ratios have been evolved from this block representation:

1. When a short is placed across R_C , V_2 is zero. A ratio of short circuit output current to the input current, I_2/I_1 , is assigned the symbol h_f or h_{21} . In the common-emitter circuit in Fig. 2, this is refer-

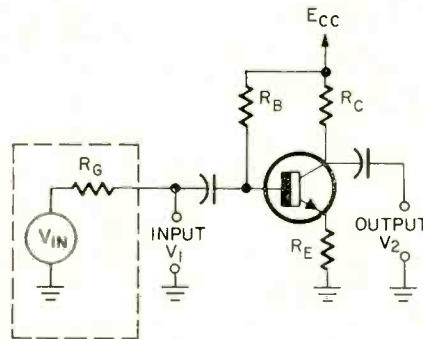

FIG. 2—COMMON-EMITTER amplifier complete with input and output circuits and equivalent input signal generator.

red to as the β_{ac} of the transistor. For the common-base circuit (discussed later in this article) the ratio is $-\alpha_{ac}$. (In future discussion, we will drop the ac subscripts after the alpha and beta symbols. Should dc conditions be considered, the dc subscript will be employed.) These current gain factors were discussed thoroughly in previous articles.

2. Maintaining a shorted output circuit, we can establish the relationship V_2/I_1 . The symbols for this ratio are h_i and h_{11} . These symbols represent the input impedance of the transistor—but only when the output circuit is shorted.

3. The output impedance can be determined from the condition when the input is open circuited and $I_1 = 0$. It is the ratio V_2/I_2 . The reciprocal of this ratio, I_2/V_2 , the output admittance, has been assigned the symbols h_o and h_{22} .

4. The final symbols, h_r and h_{12} also assume the input circuit is open and $I_1 = 0$. They are equal to V_1/V_2 , where V_1 is the voltage fed back through the transistor from the output circuit to the input and V_2 is the output voltage.

A circuit describing the transistor by using each of these relationships, is shown in Fig. 3. All circuit arrangements are represented by the same equivalent circuit and similar h-parameter symbols. In all cases, subscripts are added to the symbols to indicate the circuit involved. Thus h_{re} refers to h_r for the common-emitter mode

of operation. Similarly, a "b" added to the subscript indicates a common-base parameter is involved while the addition of a "c" means the parameter is for a common-collector circuit.

In the common-emitter circuit in Fig. 2 the signal-voltage source, V_{in} , feeding the base-emitter circuit has an internal impedance R_G . R_C is the collector load resistor. Compare this with the equivalent circuit in Fig. 3. Here, only the transistor is represented in the equivalent circuit. The impedance looking into the base of the transistor is h_{ie} , modified by the presence of $h_{re}V_2$. Similarly, the output impedance is $1/h_{oe}$ in parallel with the current source $h_{fe}I_1$. The voltage, current and power gains can also be determined from the two loops in Fig. 3.

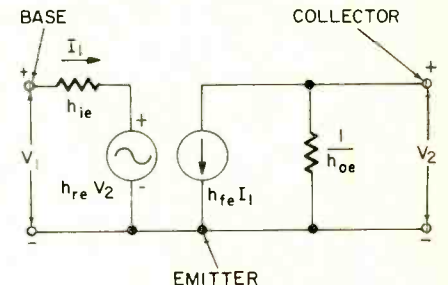

FIG. 3—HYBRID EQUIVALENT of a common-emitter transistor. Polarity markings show relative phase at any one instant.

We will now pause in our discussion of the hybrid equivalent circuit and turn to the equivalent-T network. Once this has been defined, we will tie in the two groups of analyses.

Equivalent T circuit

In Fig. 4-a, the equivalent-T model of the transistor is shown. It looks more like the actual transistor than does the hybrid equivalent network. Advantageously, it is easier to use in design and analysis procedures than is the hybrid model.

In Fig. 4-b, the input source and output load have been added to the transistor network. The input is applied between the base and emitter while the output from the amplifier stage is developed between the collector and emitter.

An ac resistor representing the internal resistance of each transistor element, is in series with each terminal inside the device. A current source due to the gain of the device appears across the collector resistor r_c ; b' is a point inside the transistor. All resistances from the ele-

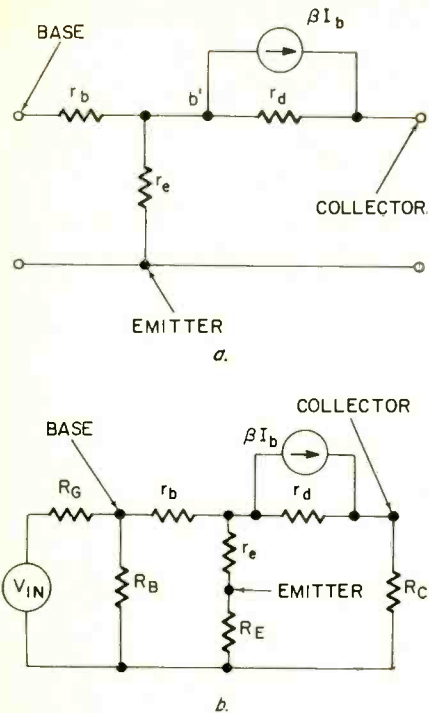

FIG. 4-a—T-EQUIVALENT of transistor in common-emitter circuit. Input and output have been added to transistor (b) for a complete equivalent of Fig. 2.

ments are connected to this point. The various resistors have been discussed in previous articles. Emitter resistor r_e , is $26/I_E$, where I_E is the quiescent emitter current expressed in milliamperes. Element r_b is the base resistance usually ranging from 200 to 800 ohms. The collector resistance is r_d for common-emitter and common-collector circuits, usually assuming values between 10,000 and 100,000 ohms. The collector resistance for the common-base circuit is r_c . It is about equal to beta multiplied by r_d . The resistors are large when the input impedance to the transistor is small.

The various bits of data about the circuit in Fig. 2 can be determined by analyzing the T-equivalent circuit when it is connected to all resistors and sources in the associated circuit, as in Fig. 4-b. The voltage source sees an impedance when looking into the transistor. It is equal to the base resistor, r_b , in addition to the sum of the emitter resistance, r_e , and the external emitter resistor, R_E , when the latter two are multiplied by beta. (As discussed in a previous article, all resistors when reflected from the emitter into the base circuit, appear in the base circuit as the emitter resistors multiplied by the beta of the transistor.) Consequently the total transistor input resistance seen by the generator is

$$R_{IN} = r_b + \beta (r_e + R_E) \quad \text{Eq. 1}$$

R_{IN} is shunted by the bias resistors R_B in Fig. 2. The source feeding the transistor sees R_B in parallel with R_{IN} .

In the drawing, $R_C + r_d$ (the collector load resistor and the internal collector resistance, respectively) are shown as shunting $r_e + R_E$. However, they do not appear in Equation 1 as they are much larger than all emitter resistors. The effect of R_C and r_d on the parallel combination is indeed minor.

In a similar manner, with similar considerations, all the other statistics for the common-emitter arrangement can be determined using the equivalent-T model. Assigning R_{OUT} to represent the impedance the collector load resistor sees by looking back into the transistor, while A_v is the voltage gain of the circuit in Fig. 2, and A_i and G are the current and power gains, respectively, of the circuit, the approximate equations derived for the common emitter arrangements are:

$$R_{OUT} = \frac{r_d [(r_b + R_C) + \beta(r_e + R_E)]}{r_b + r_e + R_C + R_E} \quad \text{Eq. 2}$$

$$A_v = \frac{\beta R_C}{r_b + \beta (r_e + R_E)} = \frac{R_C}{R_E} \quad \text{Eq. 3}$$

$$A_i = \beta \quad \text{Eq. 4}$$

$$G = A_v A_i = \frac{\beta R_C}{R_E} \quad \text{Eq. 5}$$

In Equation 2, if resistor R_B in the bias circuit is less than ten times the size of source resistance R_s , then the R_C stated in Equation 2 should be modified to $R_C R_B / (R_C + R_B)$. This is the expression for R_C in parallel with R_B .

Now let us return to the hybrid parameters we discussed earlier. Some transistor manufacturers supply only these parameters in their databooks. How can we substitute the various impedances into equations 1 through 5 if only h-parameters are provided? Simple! Let us set up equations relating the hybrid parameters to those in the equivalent-T circuit, as follows.

$$r_i = \frac{h_{re}}{h_{oe}} = h_{ie} - \frac{h_{re} h_{re}}{h_{oe}} \quad \text{Eq. 6}$$

$$r_o = \frac{1 - h_{re}}{h_{oe}} = \frac{h_{re}}{h_{oe}} = h_{re} r_d \quad \text{Eq. 7}$$

$$r_e = h_{ib} - \frac{h_{re}(1 + h_{re})}{h_{oe}} = \frac{h_{re}}{h_{oe}} \quad \text{Eq. 8}$$

$$a = -h_{re} = \frac{h_{re}}{1 + h_{re}} \quad \text{Eq. 9}$$

$$\beta = h_{re} = \frac{-h_{re}}{1 + h_{re}} \quad \text{Eq. 10}$$

Next calculate the various equivalent-T elements from the relationships in Equations 6 through 10. Substitute the calculated values of r_b , r_e , r_d , r_c and β into the T-equations 1 through 5. Now calculate the various bits of statistics about a particular circuit using T-model parameters.

The various h-parameters vary with emitter current and collector-to-emitter voltage. Curves such as those shown in Figs. 5 and 6 are normally supplied by manufacturers to describe how these parameters vary. As an example, assume the values for the h-parameters are given for $I_E = 1 \text{ mA}$ and $V_{CE} = 5 \text{ volts}$. If the value of h_{oe} at these quiescent conditions is $5 \times 10^{-5} \text{ mhos}$, and it is required to know the h_{oe} at 10 mA and 10 volts, I_E and V_{CE} , respectively, the following gymnastics must be performed.

1. From Fig. 5, the ratios of the actual h_{oe} at 10 mA to h_{oe} at 1 mA is 10. Then due to the current deviation from the specified value, h_{oe} is $10 \times (5 \times 10^{-5}) = 5 \times 10^{-4} \text{ mhos}$.

2. From Fig. 6, the ratio of the actual h_{oe} at 10 volts to the h_{oe} at 5 volts is 0.7. Multiply this by the solution found in step 1 and the required h_{oe} is $0.7 \times (5 \times 10^{-4}) = 3.5 \times 10^{-4}$.

3. Repeat this procedure for the other hybrid parameters before substituting these factors into equations 6 through 10. The vital statistics for the common-

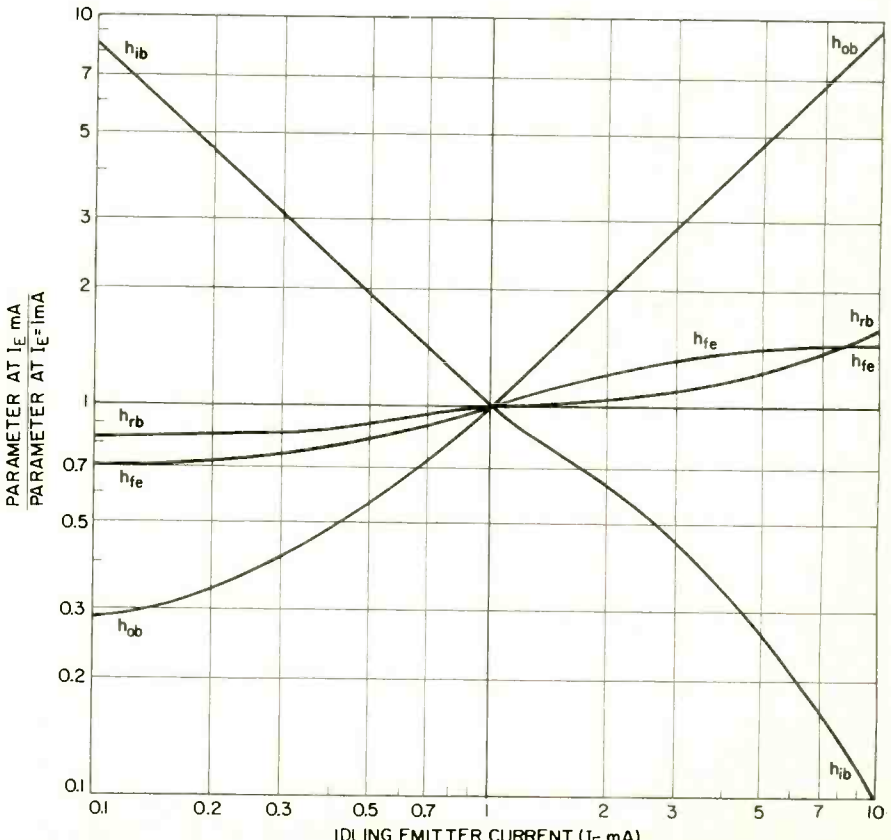
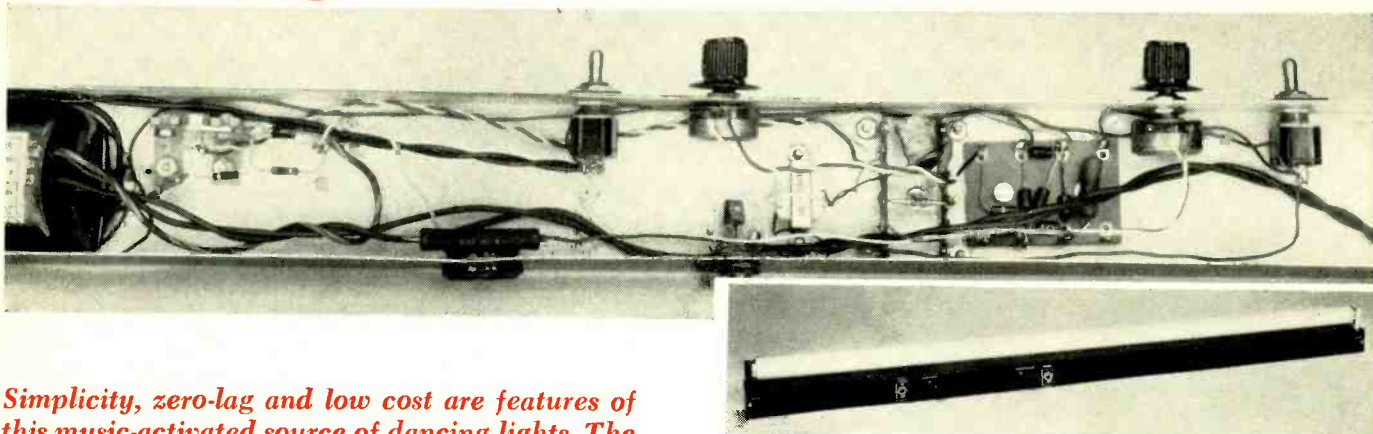

FIG. 5—HOW H-PARAMETERS VARY with changes in idling emitter current.

dancing fluorescent strobe



Simplicity, zero-lag and low cost are features of this music-activated source of dancing lights. The circuit is capable of driving up to 10 fluorescent tubes.

by CHARLES L. ANDREWS

THE FLUORESCENT LIGHT STROBE AND Music Display is the answer to a lot of problems that plague conventional light displays.

In incandescent displays you always feel that the display is "behind" the music, because of the lag inherent in all incandescent bulbs. This does not happen with fluorescent tubes, since they are basically a mercury arc with switching times in tenths of microseconds.

With this characteristic, fluorescent tubes are ideal for strobing with music, especially in tubes with a low-persistence phosphors such as blue, daylight, cool white, and blacklight. Although the bright red, green and yellow tubes have a longer persistence than the ones just mentioned, they have a much higher intensity and give a superior strobe effect many times brighter and better than an incandescent bulb.

Another problem with typical 150-watt colored spot lights is that their normal life of 2000 hours is decreased in music displays by as much as 35%. Fluorescent tubes last almost 7500 hours in flashing applications. Another consideration is the vividness of the colored light and the number of colors available. Fluorescent tubes come in 22 different phosphors going thru many shades of red, green, blue, yellow, white, and two types of blacklight. Their intensity and purity of color is unequaled by any spotlight.

Cost of the new tubes ranges from \$2.00 to \$3.00, with the exception of filter-type black light which is \$10.00. This is a considerable reduction from \$6.00 for a 150-watt spot light. It's a real bargain when you consider the

average lifetimes of the lamps.

Fluorescent tubes are better for certain types of environmental lighting displays—cove lighting, poster displays, direct viewing and floor-mounted stage lighting. Fluorescent tubes are also quite an effective complement to incandescent lighting in many areas.

Circuit operation

The General Electric dimming ballast provides filament voltage (approximately 3.5–4.5 volts) to the tubes at all times, which allows rapid starting of the tube. When the triac turns on (see Fig. 1) it fires into a typical resonant L-C-R circuit that delivers a pulse of approximately 600 volts to the tube. The width of this pulse is around 120 μ sec and will start the lamp. The voltage then drops to 200 volts or less, depending on the conduction angle of the triac at the time.

At low light levels the current flowing thru the lamp is much less than the holding current of most triacs (10–15 mA). Thus, to get smooth dimming with full range, a resistor or lamp must be a part of the triac load to keep the triac conducting. Switching this load out of the circuit causes a brilliant strobe effect.

The firing circuit is conventional. A bridge rectifier provides full-wave rectification. The Zener diode clips the full-wave pattern at 20 volts. Since a 117-volt wave form is clipped, there is a much greater percentage of the waveform at 20 volts, which allows a much wider range of control than might be possible with a 24-volt transformer.

The 200,000-ohm BACKGROUND

control allows full dimming and shut-off of the lamp with no signal applied. It is useful in music and music-strobe applications to set the depth of effect desired.

Input transformer T1 steps up the voltage taken from the speaker terminals. This voltage is rectified by diode D6. This voltage is applied to the 0.1- μ F capacitor and charges it to the firing potential of the unijunction transistor. When the unijunction fires, a positive pulse is applied to the triac through the isolating pulse transformer.

Two alternate diodes are in series with the triac along with a voltage divider to help share any transient voltage during turn-on.

Using the circuit

Begin by connecting the power and closing switch S2. Now you can vary the 200,000-ohm BACKGROUND control from full-on to full-off with no music input. Next, connect input jack J2 across the speaker terminals. Adjust the sensitivity to the point where there is a fluctuation in light intensity corresponding to the intensity of the music. You may wish to set the "depth" of this effect by adjusting the background control, which will bias the circuit at some level of illumination.

In the MUSIC-STROBE position (S2 open), sensitivity is adjusted so the light flashes with the higher sound levels. In some cases you might want to bias the light in conduction at some minimum level to cut down on the intensity of the strobing action.

A female socket on the back of the fixture allows control of a 100-watt

Lightning and color TV sets

Lightning can literally destroy parts of a TV set. Here's a way to protect the TV and your customer

by **EUGENE CUNNINGHAM**

A BOLT OF LIGHTNING IS A LARGE group of electrons going somewhere in a terrible hurry—or a heavy current. Heavy currents create big magnetic fields and all color TVs are extremely allergic to magnetic fields. They are also not too fond of having assorted bits and pieces of circuitry blown apart, arced-over and otherwise disrupted.

So if you run into a color set which shows very odd symptoms, check to see if it has been visited by a thunderbolt. Here are a few things to look out for.

Impurity. If the screen shows "all kinds of colors all of a sudden" this is a pretty good sign. A "near-miss" in the vicinity can magnetize a color tube so badly that you may not even be able to see color on a color program. Not in the right places anyhow. There will be lots of color, but all in the wrong places. This could even be interpreted as a complete loss of color signals, but watch out. Don't dig into the color circuits until you have demagnetized that tube. I have seen this bring the color back to "perfect".

You can see some oddballs, too. One set I know of always shows a bright pink spot about 6 inches in diameter right in the middle of the screen, every time lightning hits anywhere nearby! I ought to know—it's *mine*. Degaussing clears this up completely until the next time.

If the screen is badly impure, but responds to degaussing and the impurity creeps back in, after it's been turned on and off several times, check the auto-degaussing coil and its associated thermistor and VDR (voltage dependent resistor). The VDR may have been damaged which will make the degausser work "in reverse". For a good test simply disconnect the coil and let it play for about a week. If the screen remains pure, that's it. Try a new VDR, since it is the most likely cause.

Blowups and flashovers

You'll find all the normal symp-

toms of lightning damage too, of course. Balun coils burned up, line-bypass capacitors, circuit breakers and fuses blown to bits, rectifiers shorted are just a few examples. After clearing up these problems, check all nearby printed-circuitry.

In a few cases, a hard hit has been known to blow the delicate conductors clean off the boards. In one rare case, the bolt apparently jumped from the antenna terminals to the convergence board (on the back of the cabinet about 3 inches away). Here it completely stripped off the ground conductor running all the way around the outer edge of the board!

Antenna problems

Antenna boosters, especially the top-mounted types, are vulnerable to lightning damage. The early transistor boosters were particularly "touchy" about lightning, but the newer versions can take it as well as the tube types. On a direct hit, any type will blow.

One very odd problem came up in a lightning-damage case. It was apparently a direct short across the

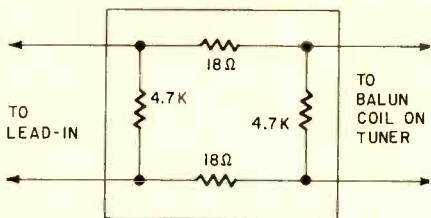

A RESISTIVE PAD added between the antenna lead-in and tuner input terminals will reduce potential lightning damage.

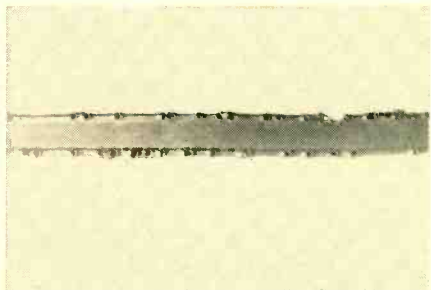

BLOWN LEAD-IN WIRE was the result of a lightning strike on the TV antenna.

antenna insulators! With the construction of folded-dipole antennas, this is difficult to test without a lot of drilling out of rivets, etc. However, the best clue here is the signal strength: if this is far below normal, check the antenna and lead-in.

A good "hard hit" may blow the lead-in see the photograph below. Here, the conductors have vanished completely, vaporized by the current. This will show up on an ohmmeter check from the set, of course.

One thing will often help to prevent heavy damage to the color set: add a small resistive pad between the antenna lead-in and the tuner input terminals, (see diagram). This won't cause a great loss of signal, if the series resistors are small and the shunt resistors fairly big. Be sure to use the smallest-wattage resistors available. Never more than ½ watt—less if possible. The idea here is for the resistors to vaporize instantly, saving the balun coil. This has been known to happen in several instances.

The mast or tower must be very well grounded and a good lightning arrester connected to the lead-in at the point where it goes into the house. We can't *stop* ("arrest") lightning, but with luck we can keep it out of the house. On the arrester, use a first-rate ground connection right below the unit itself.

General hints

Finally, if you still have trouble after you've found and fixed all of the obvious things, look out for what is called "streak" damage. This is a carbonized path across any kind of *insulator* (pc boards, terminal strips, even tube sockets). The clue is the faint dark streak across light-colored insulating material. In one real-dandy type of case, we found one on the socket of the rf amplifier tube. This did nothing at all for the grid bias.

There's no way to *stop* lightning from striking, but with a little forethought, and the correct techniques, you can reduce the damage that it does.

R-E

POWER SUPPLIES

using the μ A723

Regulated power supplies can be easy to build if you design them around available IC's. Here are two circuits for low-current low-voltage designs

by WALTER G. JUNG

To some people power supplies are quite unexciting. Others find them intriguing. Regardless of your own personal viewpoint they are a necessary evil, something you must have before power can be applied to any circuit no matter what its type. But with the IC's we'll be discussing here you can build a power supply as good as any home experimenter will ever need. In this initial circuits discussion we'll develop a family of power supplies based mainly on the μ A723 regulator. You'll see how to tailor the output voltage to your exact requirements, how to build in the power capability for higher current outputs (up to several amps). How to provide a current limiting feature to protect your experimental projects (as well as the supply itself) and provide multiple output voltages. We'll cover both standard voltages for specific applications and a wide range "general purpose" circuit. The standard circuits you can use over and over on individual projects with the confidence of good performance. The general purpose supply you may want to build as a shop tool for powering circuits in the experimental stage.

The standard voltages these supplies will deliver are +5 volts (for IC logic projects), +12 volts, -12 volts and a symmetrical + and -12 volt supply for op-amp circuitry. We also show you how to build an extended range supply that will put out ± 3 to ± 15 volts. With this wide range supply you can power any experimental circuit within this voltage range. The negative output is made to track the positive output, so by set-

ting in a value of positive voltage (+6 volts for instance) the negative output automatically becomes equal and opposite. All supplies have current limiting and a standby mode, if desired, allowing temporary shutdown. (The first two circuits are presented this month.)

Let's start off by looking at a basic +12 volt regulator. In Fig. 1 we see the 723 being used to supply a regulated 12 volts at 100 mA. D1, D2 and C1 form a fullwave rectifier, supplying raw unregulated dc to the 723. Since the 723 contains all necessary voltage reference, amplification and series control transistors, a simple two-resistor divider on the output is all we need for a fixed output voltage. The internal reference of the 723 is 7 volts, so for a 12-volt output we need to "scale up" the divider. By using this 12-volt supply as an explanatory example now, you'll see how you can change the output voltage of this basic circuit to suit your own purposes.

The internal control amplifier of the 723 is a differential amplifier. One side of this differential amplifier is fed a reference voltage (in this case the nominal 7.15 volts on pin 3 of the metal-can TO-5 package) and the opposite side senses the output through the divider, this feedback action providing the regulation and control. Since a balanced differential amplifier will have both input bases at very close to the same potential, the tap (R2-R3 junction) on the divider will also be at 7.15 volts. If we set a nominal bleeder current in the divider of about 1 mA, this makes R3 6800 ohms. Then R2 must make up

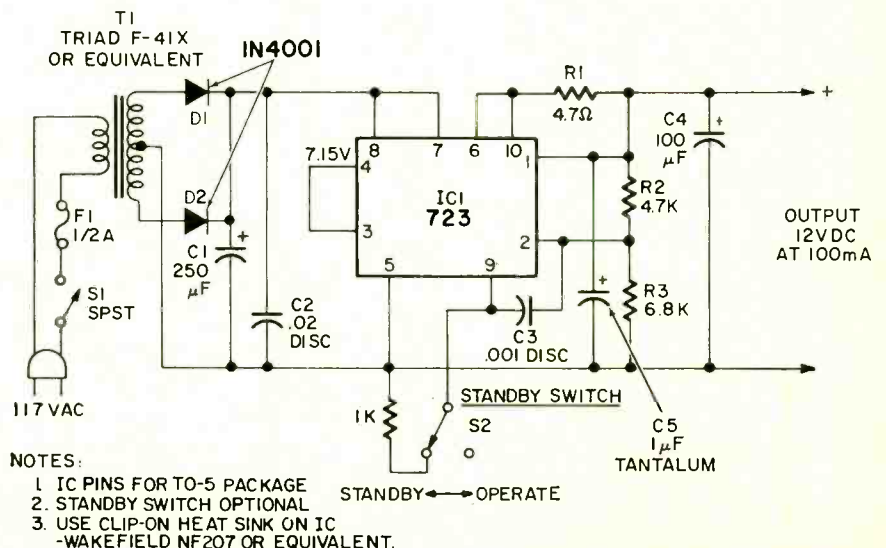

FIG. 1—BASIC REGULATOR delivers 12 at 100 mA. Resistor divider sets output.

the difference for 12 volts, and the voltage across it will be $12 - 7.15$ or 4.85 volts. By Ohm's law, $R_2 = \frac{4.85}{1.05} = 4.7K$

(since 7 volts across 6800 ohms will be slightly more than 1 mA, or 1.05 mA). It's as simple as that—set 1 mA in the divider and select R_2 to make up the difference in voltage between the desired voltage and 7 volts. You can set the output to values other than 12 volts by choosing different values of R_2 with R_3 remaining as 6800 ohms. For instance, if you wanted a 10-volt regulator, the procedure would be as follows:

E across $R_2 = E_o - 7.15$ or $10 - 7.15 = 2.85$ volts. Since $I =$ constant of 1.05 mA, $R_2 = \frac{2.85}{1.05}$ or 2.7K in this case.

If this procedure is not exact enough and you want to set the voltage precisely at some value, insert a 2000-ohm pot between R_2 and R_3 and feed pin 2 of the 723 from the arm. Then you'll be able to trim out the tolerances of the resistors and the 7-volt reference, and set your output to precisely the desired value.

By either method the output remains stable once set, due to the inherent stability of the IC chip. Use quality resistors for R_2 and R_3 if possible; well derated, deposited carbon or film types if available.

As for the rest of the circuit, C_3 provides internal frequency compensation for the IC's control amplifier. Two more capacitors are used on the output, C_4 and C_5 . C_4 is a fat electrolytic to provide energy storage for current peaks and keep the regulator's output impedance low at higher frequencies where the 723's gain falls off. C_5 provides more insurance against this high-frequency impedance rise, taking over where the internal inductance of C_4 begins to kill its effectiveness. The combination of these capacitors and the load regulation of the IC combine to make truly effective regulation. The remaining capacitor, C_2 , is a ceramic disc used as a high-frequency bypass on the

input lines. This capacitor should be placed directly across the IC's input leads to stop any tendency towards the 723 believing it's an rf oscillator.

The remaining circuit component is R_1 , the short-circuit limit resistor. Since it is in series with the circuit's output current, it develops a voltage drop proportional to the load drawn at the output. This voltage is used to turn on an internal transistor at a predetermined output current, thus protecting both the IC and the external load. This operation is automatic, and normal operation is restored as soon as the output load is reduced to normal limits. The value shown will current limit at about 150 mA, a reasonable figure for the 723 without a booster stage. When we see some really powerful regulators (1 to 2 amps in future articles) this resistor will reduce proportionately. To calculate a new value of R_1 (for a different short-circuit current maximum) the formula is simple. Since the voltage drop across it is $1 V_{io}$

(about 0.7 volt) it is $R_1 = \frac{0.7}{I_{max}}$. Should you want to protect this 12-volt circuit at a lower limit, say 70 mA; R_1 would be $\frac{0.7}{.07} = 10$ ohms. In any case the short-circuit current should be about 25% greater than the maximum load current.

So much for all the talk on what the circuit components do. How well does it work? A regulated 12 volts can be supplied with load regulation better than 0.1%. Line regulation is even better than this, and ripple less than 1-mV peak to peak. The current-limit feature can be used to protect against those inevitable load short circuits very effectively, preventing destruction of valuable components. This circuit will be more than adequately precise to power any positive voltage requirement we will be discussing here; and by using a current booster modification, with up to several amps of output current. To scale the output voltage and for different current limit capability, follow the guidelines given above.

For output voltages higher than 12 volts the procedure for R_2 selection is exactly the same. The power transformer output voltage must be raised to accommodate the extra voltage, however. The Triad F-41X specified here is fine for regulated outputs up to 12 volts. But since the 723 needs about 3 volts minimum difference between its input and the regulated output, the unregulated dc must be high enough to suit this requirement.

For a 20-volt regulator you need about 23 Vdc minimum at pins 7 and 8 of the IC. And of course, you'll have to up the voltage ratings on the capacitors to suit your higher working voltages. A good choice in flexibility which gets around this dc requirement are the variable tap rectifier transformers which allow you to set the unregulated voltage output closely to what the regulator requires and minimize the power the 723 has to drop in accomplishing its regulation. Remember, the price of regulation is power dissipation and if the voltage drop across the IC gets high enough at substantial load currents it can get hot. Its power dissipation is roughly $(E_{in} - E_{out}) \times (I_{out})$, and should be kept below 800 mW for safety's sake and longevity. Later on in the high power regulators we'll see how the IC's dissipation can be effectively reduced to a negligible minimum.

Low-voltage 723 regulator

By now it has probably occurred to the reader that the circuit in Fig. 1 makes no provision for output voltages below the 7-volt reference. But don't give up yet! To do this we use the circuit of Fig. 2, a +5 volt example suitable for powering IC logic devices such as gates and flip-flops. In this version, instead of connecting the 7-volt reference voltage (developed in the IC at pin 4) directly to 3, it is divided down to the desired output level (in this case 5 volts) and then applied to pin 3. No divider is used on the output and pin 2 senses the output through isolation resistor R_4 . Using the 723 in this manner causes the output voltage to exactly duplicate the potential applied to pin 3 from 2 up to the maximum of 7.15 volts (reference voltage). If a fixed 5-volt output is not desired, a variable 2 to 7 volts can be obtained by making R_2 and R_3 a variable divider.

The lower regulation limit of the IC is 2 volts, and you should not try this circuit below this limit. This arrangement covers all of the most often used lower supply voltages; 3.6 volts, 5 volts and 6 volts.

This makes this regulator hookup quite attractive as a logic power supply, where current demands can very quickly get up into the hundreds of milliamps or even ampere region. To use this circuit as it stands would be inefficient for a large scale project, but it is fine for applications requiring less than 70 mA. The reason behind this limited current drain is one of efficiency, because at the lower output voltages the IC dissipates the bulk of the input power when feeding a load. This is the reason why a clip-on heat sink is recommended. **R-E**

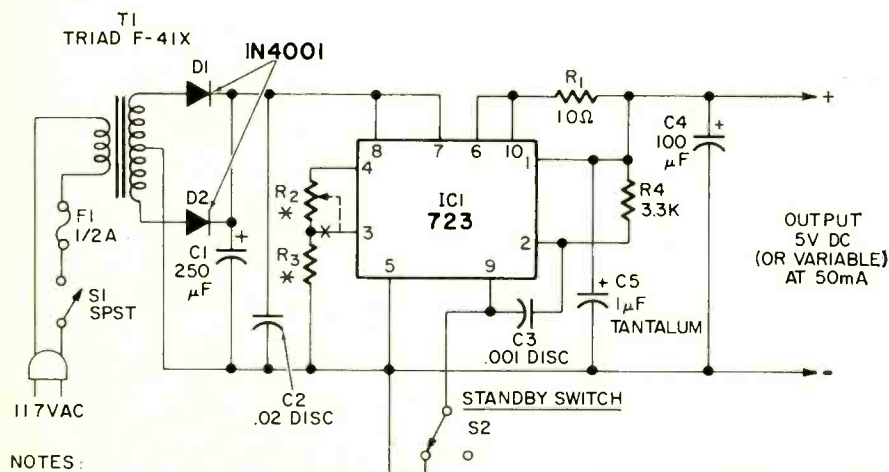

NOTES:

1. IC PINS FOR TO-5 PACKAGE
 2. STANDBY SWITCH OPTIONAL
 3. USE CLIP-ON HEAT SINK ON IC - WAKEFIELD NF207 OR EQUIVALENT.
- FIG. 2—VARIABLE OUTPUT VOLTAGE or 5 Vdc is delivered by this circuit.**
- * FOR FIXED 5 VOLT OUTPUT $R_2 = 2.2K$, $R_3 = 5.1K$. FOR VARIABLE 2-7 VOLT OUTPUT $R_2 = 5K$ POT (CONNECTED AS SHOWN DOTTED) AND $R_3 = 2.2K$

GETTING THE MOST

FROM YOUR TAPE CASSETTES

Cassette recorders are tricky machines. How you select, use and handle the tape cartridges that go with them can make a big difference in how they sound. Try the easy-to-use tips presented here.



Photo courtesy Magnavox

JULY 1971

by **MATTHEW MANDL**
CONTRIBUTING EDITOR

UNDOUBTEDLY THE FASTEST-GROWING area in home entertainment is the cassette tape player and recorder. The popularity of this tape-recording method includes the inexpensive cassette monaural portable player-recorder units, the stereo decks you can add to your present hi-fi system, plus the higher-priced changers which run through a stack of cassettes as easily as a record changer goes through its motions.

The enthusiastic acceptance of the cassette system stems from the advantages cassettes have over the reel-to-reel processes. Since we still are involved with the electronic problems of recording on tape, however, some precautions are necessary to obtain the best results possible. In addition, if you want to improve performance or upgrade your system, you must become familiar with the basic aspects of cassettes and the avenues open for getting the most out of your system.

Instead of open take-up and feed reels, the tape is totally enclosed in the cassette. Internally, only hubs are used for mounting the tape, with the container sides replacing the reels as tape holders. Thus the cassette makes a neat compact package measuring $\frac{1}{2}$ " x $2\frac{1}{2}$ " x 4", that requires no tape threading or handling.

Cassettes can be wound fast forward or reverse just like open-reel tapes. They can be interrupted easily and stored conveniently since no rethreading is required to get the tape on one reel as with open-reel tapes.

Another feature is compatibility between monaural and stereo recordings—a condition not present for the open-reel recorders. Thus, you

can play your stereo cassettes on a portable monaural machine, or play mono tapes on a stereo deck. There are several differences between the recording process for the cassette and the open-reel type. First, in the cassette, left- and right-channel tracks for a given direction are side by side, thus permitting playing such a recording on a mono machine. For the open-reel process, however, the tracks are interlaced, preventing their being played on mono machines. Cassette tapes are available with playing times of 30 minutes (15 minutes each side), 90 minutes (45 minutes per side), and 120 minutes (one hour each side). A big feature is erasing, a problem which often plagued open-reel machines. The erase protection has been standardized for virtually all cassette recorders. As shown in Fig. 1, a breakout tab for each recording direction is in the rear of the cassette. Once you break these out with the end of a penknife blade, the record button on the machine is inoperative, preventing accidental erasure of recorded material.

You can, however, erase (or re-record) on cassettes which have missing tabs by pasting a piece of plastic tape over the tab opening while recording. (Make sure you remove the tape after recording to restore accidental erase protection.) Some hi-fi stores now sell plastic spring-like clips to place over the tab openings when re-recording is required.

Recording quality

Your cassette tape is about $\frac{1}{4}$ " wide (0.146") compared to open-reel tape which is about $\frac{1}{4}$ " wide (0.246"). The cassette tape speed is only $1\frac{1}{8}$ " ips while open-reel tape recorders have a variety of speeds.

The higher the speed, the better the frequency response and the lower the noise.

Since cassette tape is so narrow, squeezing four stereo tracks in, reduces each track to 0.024", with 0.012" separation between left and right channels of a particular pair, and 0.026" separation between stereo pairs. Such narrow tracks, together with the slow tape speed, limit the amplitude and frequency response of the signals that can be placed on the tape. Since the amplitude is low, additional stages of audio must be provided to raise the gain, and background noise rises. Frequency response in older machines was between 60 Hz and 100 Hz at the low end and around 10 kHz at the high end. Improvement in heads and tapes, however, has pushed the response of most newer machines to an acceptable hi-fi range between 30 Hz and 12 kHz.

In open-reel tapes, the least costly is acetate which is suitable for most general purposes and is widely used in the bargain-priced 1.5- and 1.0-mil tapes. Polyester tape is considered to have the best quality base material since it is many times stronger than the acetate and does not break too readily under stress. (The Dupont polyester is called *Mylar*.) The polyester base material is used for the 0.5-mil (triple play) open-reel tapes, thus assuring the required strength for this very thin tape. It is also used in the cassette tape units, and is a must for the extended play C-90 (90 minute tapes) and C-120 (two-hour tapes).

Noise reduction

In any signal-amplifying system, the signal-to-noise ratio is an impor-

tant factor. The more you can raise the signal above the noise level, the less noise interference you will hear at the output. If, however, the noise level is fairly high, it becomes difficult to raise the signal above it for complete noise elimination. Thus, for the critical noise factors in cassettes, it is important to use high-quality magnetic materials on the tapes and employ top-performing heads and amplifiers.

It is easy to check tape sensitivity differences. Record the same selection from a record on several of your blank tapes, using the same control settings. Now listen to the differences on playback. You'll find that the more expensive cassette tapes with better quality magnetic materials are much louder on playback. Thus, by reducing the output level of such tapes to an acceptable listening level, we reduce the noise factor compared to cheaper tapes. If your playback machine has level meters showing playback amplitudes the differences are even more noticeable.

Buying a cassette recorder

If you are in the market for a new cassette unit, read the specifications carefully and select one which provides the most for your money. Frequency response alone is not the total answer to good quality—harmonic distortion, even tape movement, low noise, and a crisp response, are all factors. With good tape and a high-quality recorder-playback machine, the reproduction is surprisingly close to what you'd expect from a good system for hi-fi disc playback.

For the ultimate in noise reduction, you can buy a machine with the Dolby noise-reduction system built in, or you can buy a separate Dolby-system unit (see *All About Dolby*, **Radio-Electronics**, June 1971). High-frequency noise and hiss are reduced substantially by the Dolby process. Functionally, it boosts signals which fall below a predetermined level and reverses the process during playback. The boost is about 10 dB, determined by the specific frequency involved, and during playback the decrease is the same amount. Because the boost lifted the weak signals above the constant-level noise, the signal-to-noise ratio is improved dramatically.

Tapes made with the Dolby system can be played on an ordinary machine, but you'll have to turn down the treble to make them sound right. Since the Dolby system, when built in, increases the total cost by about \$50 to \$75, you will have to decide whether the increased quality is worthwhile to you.

Improving the mono unit

Portable mono cassette machines

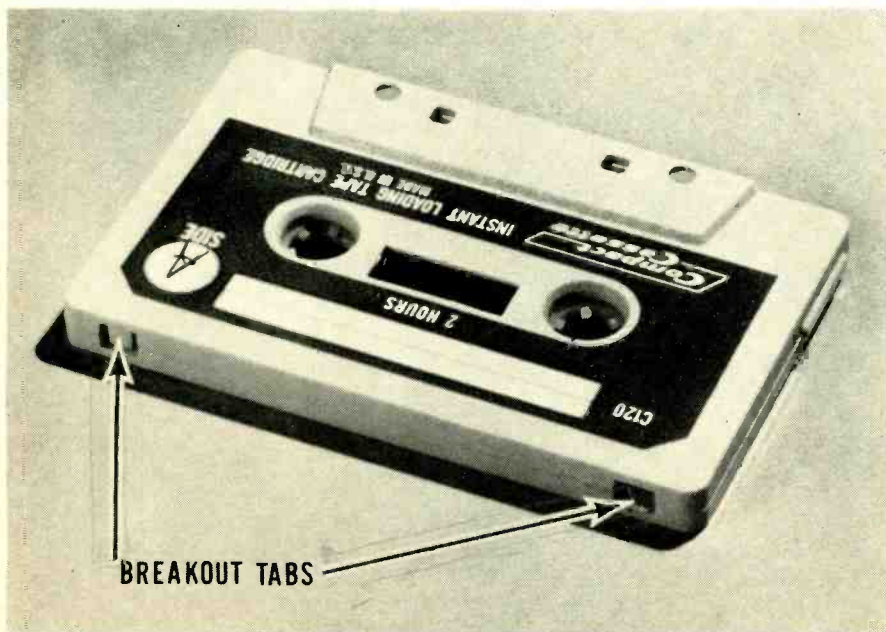

FIG. 1—BREAKOUT TABS HELP PREVENT accidental erasure of tape cassettes. Once the tab is removed, machine cannot record.

are limited in quality primarily by the small internal speaker and housing. Surprisingly, their solid-state circuitry can provide much superior sound. If you use a good tape you can improve the quality a little on the portables. When, however, you use the mono machine in a fixed location, you can get much higher quality by using an external speaker.

If you have a fairly good speaker on hand (8" or larger) you can attach a plug to the terminals and plug it into the recorder's phone output jack. Most of the portable machines omit the series resistor for phones, used in higher audio-power units. So they deliver full volume to an external speaker. While you won't get much louder results, you will get better low-frequency response and a definite improvement in output sound quality.

Keep your machine in good operation by regularly cleaning the heads. Many cleaner fluids are now available at your hi-fi center, as are special cassettes of head-cleaner tapes. In particular keep the capstan roller clean and the bearing oiled at all times. This moving part must grip the tape tightly and move it along without slipping or binding.

When tapes are not in use keep them in their container with the flanges holding the tape rollers. These flanges keep the tape from unwinding and reduce the possibility of tape wrap-around at the capstan post and roller. It is a good idea to check the cassette to make sure the tape is not slack.

Tape repairs and splicing

The lower-priced cassette tapes have the cassette cases press-molded together. These cases sometimes warp and prevent free movement of tape inside the cassette. When tape binds, it may wrap around the pinch roller or capstan post. The higher-priced cassettes are put together with screws and provide much better alignment.

If you suspect trouble in tape movement, try the cassette on fast forward and reverse. There should be no slow up of tape speed on forward or rewind. Sometimes a drop of oil at the hubs may help, as shown in Fig. 2. Be careful not to over-oil here, however, or the oil will run into the tape windings.

If trouble persists, repairs can be attempted, particularly if the cassette is held together with screws. After removing the screws, pry the two halves of the cassette apart carefully while resting the unit on a table top. The tape is not in reels, but is wound around two hubs. The sides of the cassette housing hold the tape in spool fashion.

With the top off, inspect the in-

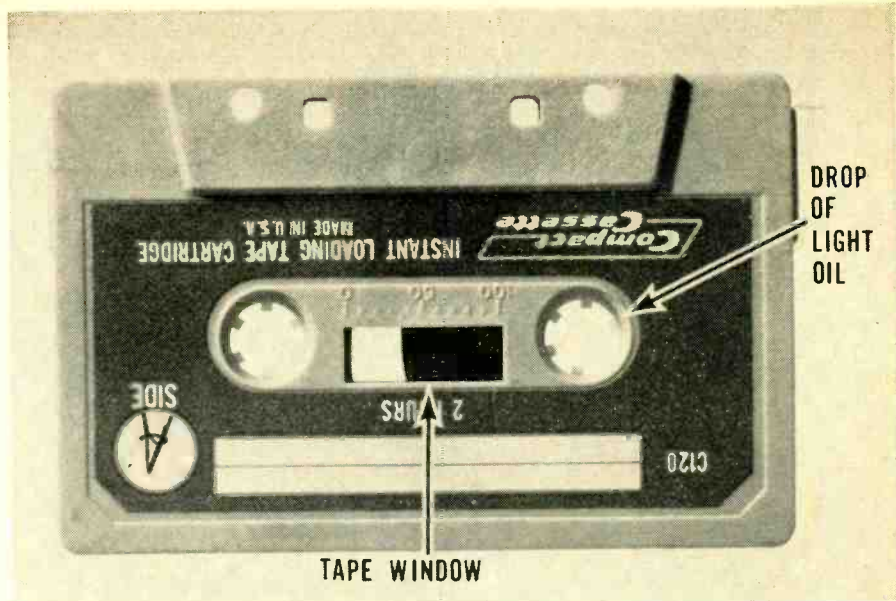

FIG. 2—A DROP OF LIGHT OIL at the hubs of tape cassette can prevent tape slowdown. Don't let any oil get onto tape itself.

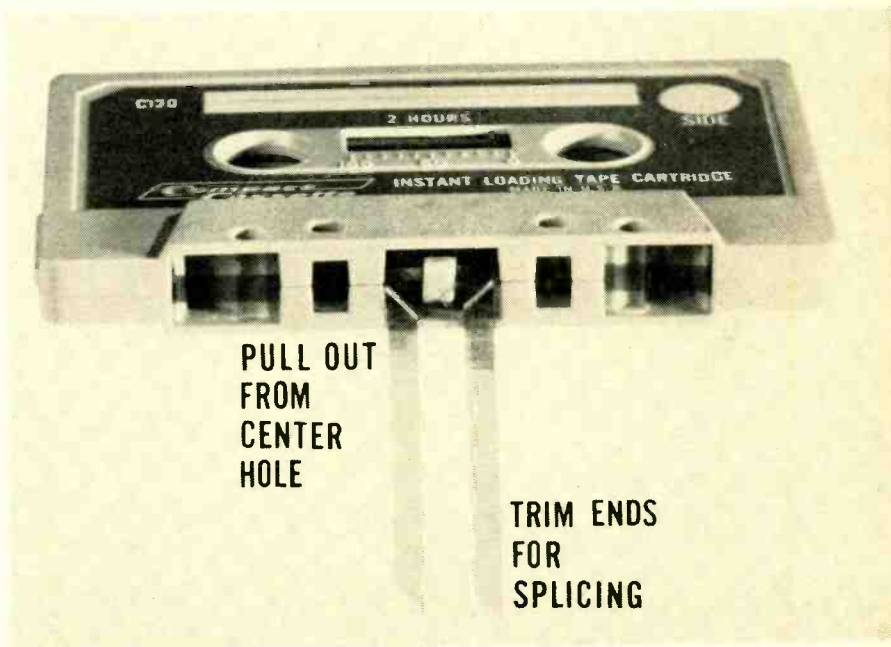

FIG. 3—TO TRANSFER TAPE from jammed cassette to new cassette, start by pulling out and cutting tape leader end. See text for full description.

side and note whether the tape has slipped off a post or is being pinched by uneven plastic glides. A small pen-knife blade, an awl, and small tweezers are handy for making corrections.

If glide posts or other internal sections are broken or warped and are beyond repair, you can still salvage the tape if you want to save some valuable program material or recordings you've made. This is done by using an inexpensive blank tape cassette.

As shown in Fig. 3, the tape is pulled out from the center hole and cut for splicing. One end of the tape from the damaged reel is spliced to one end of the new cassette, and the hub turned with a sharp-pointed tool, such as an awl, to wind the salvaged

tape onto the new cassette. When all the tape has been wound up, cut the end of the salvaged tape loose and splice it to the other end extending from the new cassette.

The work is delicate and greater care has to be taken than for 1/4" open-reel tape. Commercially available splicers are recommended, since static electricity interferes with precise handling of the narrow and thin cassette tape.

Press-molded cassettes are virtually impossible to open without damaging the casing. If the tape binds, but can still be pulled out, the best procedure is to rewind the tape on new cassettes instead of trying to make repairs.

R-E

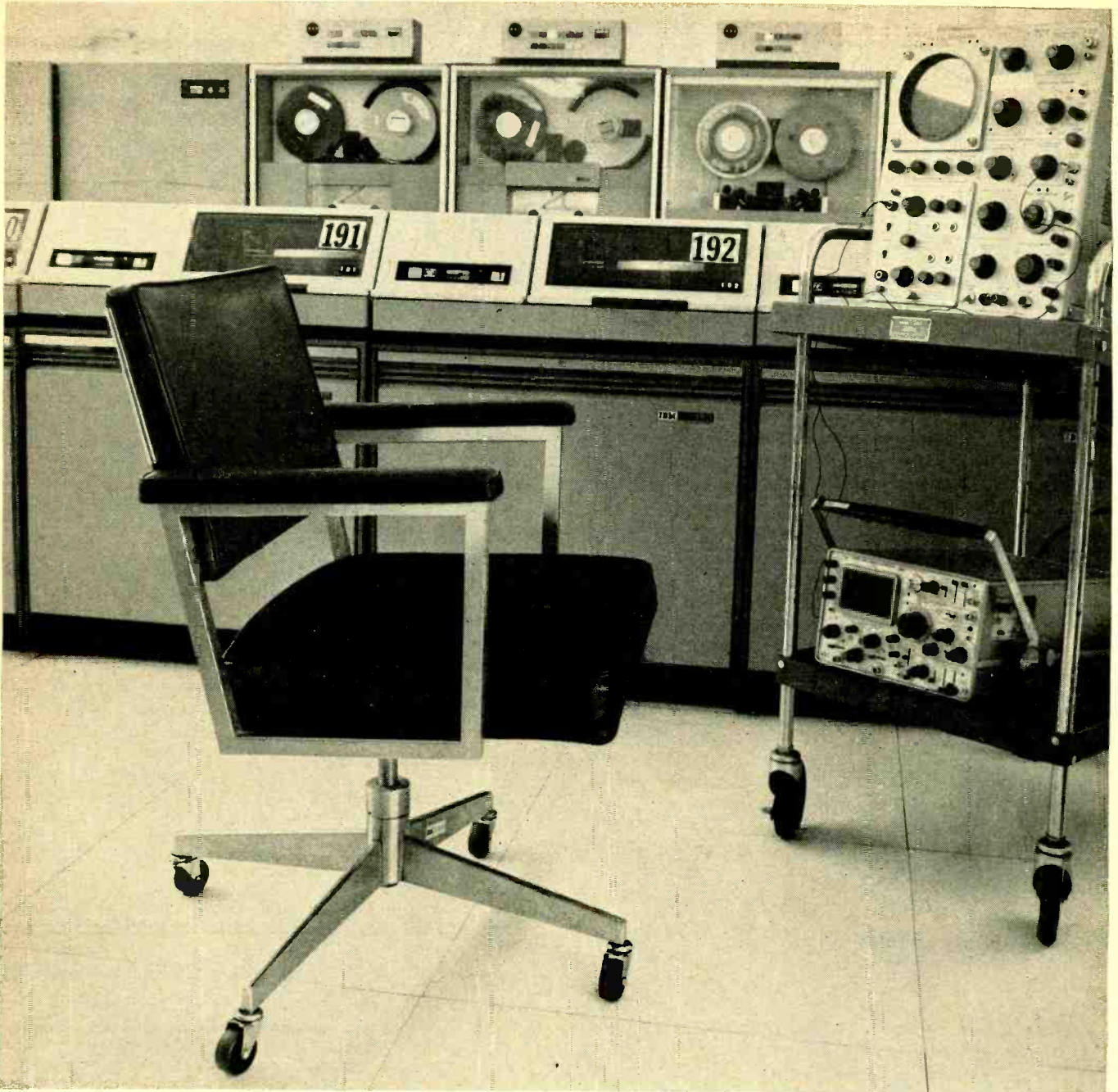

This important job (and its big income) is reserved for a qualified electronics technician. It can be you!

It's a fact. There are *thousands* of jobs like this one available *right now* for skilled electronics technicians. What's more, these men are going to be in even *greater* demand in the years ahead. But how about you? Where do you fit into the picture? Your opportunity will never be *greater* . . . so act *now* to take advantage of it. The first step? Learn electronics fundamentals . . . develop a practical understanding of transistors, trouble-shooting techniques, pulse circuitry, micro-electronics, computers and many other exciting new developments in this growth field. Prepare yourself now for a job with a

bright future . . . unlimited opportunity with lasting security . . . prestige and a steadily growing paycheck.

Cleveland Institute of Electronics courses have been stepping stones to good jobs in electronics for thousands of ambitious men. Why not join them? You can learn at home, in your spare time, and tuition is remarkably low. Read the important information on the facing page. Then fill out the postage-free reply card and drop it in the mail today. Without obligation we'll send you all the details. But act now . . . and get *your* high-paying job just that much sooner.

How You Can Succeed In Electronics ... Select Your Future From Seven Career Programs

The "right" course for your career

Cleveland Institute offers not one, but seven different and up-to-date Electronics Home-Study Programs. Look them over. Pick the one that is "right" for you. Then mark your selection on the bound-in reply card and send it to us. In a few days you will have complete details... without obligation.

1A. Electronics Technology

A comprehensive program covering Automation, Communications, Computers, Industrial Controls, Solid-State Devices, and preparation for a 1st Class FCC License.



1B. Electronics Technology with Laboratory

Includes all areas of Course 1A including 1st Class FCC License preparation. In addition, student receives 161-piece Electronics "Learning Laboratory" and 17 "lab" lessons for "hands-on" experience.



2. Broadcast Engineering

Here's an excellent studio engineering program which will get you a 1st Class FCC License. Now includes Video Systems, Monitors, FM Stereo Multiplex, Color Transmitter Operation and Remote Control.



3. First Class FCC License

If you want a 1st Class FCC ticket quickly, this streamlined program will do the trick and enable you to maintain and service all types of transmitting equipment.

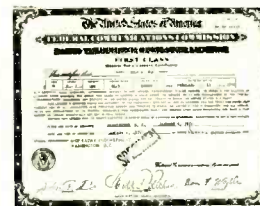

4. Electronic Communications

Mobile Radio. Microwave and 2nd Class FCC preparation are just a few of the topics covered in this "compact" program. Highly recommended for jobs with telephone companies.



5. Industrial Electronics & Automation

This exciting program includes many important subjects such as Computers, Electronic Heating and Welding, Industrial Controls, Servo-mechanisms and Solid-State Devices.



6. Electronics Engineering

A college-level course for men already working in Electronics... covers Steady-State and Transient Network Theory, Solid-State Physics and Circuitry, Pulse Techniques, Computer Logic and Mathematics through Calculus.



An FCC License... or your money back!

In addition to providing you with comprehensive training in the area indicated, programs 1A, 1B, 2, 3 and 4 will prepare you for a Commercial FCC License. In fact, we're so certain of their effectiveness, we make this exclusive offer:

The CIE courses described here will prepare you for the FCC License specified. Should you fail to pass the FCC examination after completing the course, we will refund all tuition payments. You get an FCC License... or your money back!

CIE's AUTO-PROGRAMMED® Lessons help you learn faster and easier

Cleveland Institute uses the new programmed learning approach. Our Auto-Programmed Lessons present facts and concepts in small, easy-to-understand bits... reinforce them with clear explanations and examples. Students learn more thoroughly and faster through this modern, simplified method. You, too, will absorb... retain... advance at your own pace.

Lifetime job placement service for every CIE graduate... at no extra cost

Once enrolled with CIE, you will get a bi-monthly listing of the many high-paying, interesting jobs available with top companies throughout the country. Many CIE students and graduates hold such jobs with leading companies like American Airlines, AT&T, General Electric, General Telephone and Electronics, IBM, Motorola, Penn Central Railroad, Raytheon, RCA, Westinghouse and Xerox... to name a few.

CIE Lessons are always up-to-date

Only CIE offers new, up-to-the-minute lessons in all of these subjects: Logical Trouble-shooting, Laser Theory and Application, Microminiaturization, Single Sideband Techniques, Pulse Theory and Application, Boolean Algebra and Solid-State Devices.

New Revised G.I. Bill Benefits:

All CIE courses are approved for full tuition reimbursement under new G.I. Bill. If you served on active duty since January 31, 1955, OR are in service now, check box on reply card or coupon for latest G. I. Bill information.

CIE Cleveland Institute of Electronics
1776 East 17th Street, Cleveland, Ohio 44114

If card has been removed, mail this coupon for 2 FREE BOOKS

Cleveland Institute of Electronics
1776 East 17th Street, Cleveland, Ohio 44114

Please send me without cost or obligation:

1. Your 44-page book, "How To Succeed in Electronics."
2. Your book on "How To Get a Commercial FCC License."

I am especially interested in:

- | | | |
|---|--|--|
| <input type="checkbox"/> Electronics Technology | <input type="checkbox"/> Broadcast Engineering | <input type="checkbox"/> Electronic Communications |
| <input type="checkbox"/> Electronics Technology with Laboratory | <input type="checkbox"/> First Class FCC License | <input type="checkbox"/> Industrial Electronics & Automation |
| | <input type="checkbox"/> Electronics Engineering | |

Name _____ Age _____
(please print)

Address _____

City _____ State _____ Zip _____

Veterans & Servicemen:
check here for G.I. Bill information.

Accredited Member National Home Study Council.

RE-92

Circle 6 on reader service card

CosCo does it all - - - with color organs, color-controllers and strobes



Model D 35—3 channel audio lite

Transform your sounds into a kaleidoscope of color and movement with a variety of light displays and color controllers from room-size to stage-size.



Model C 2000 A
4 channel controller, to 4000 watts



Model MS 200
commercial size strobe

Or create a visual experience of stop-action strobe bursts you'll still be feeling two days later.

Jump up and send for our free color brochure and get a peek at all the CosCo goodies.

CosCo Research, Inc.

P.O. Box 17, Colo. Springs, Colo. 80901
303/473-1950

Circle 7 on reader service card

EQUIPMENT REPORT

Kikusui "Alignment Scope" Model 5121

For manufacturer's literature, circle No. 16 on Reader Service Card.

THE KIKUSUI MODEL 5121 "ALIGNMENTSCOPE" is a specialized test instrument which could be very handy indeed. It is intended strictly for use with sweep signal generators, for displaying i.f. and rf alignment curves, etc. For the service shop with a specialized sweep-alignment position, or for production-line final alignment or testing, it would be nice.

This will probably be the biggest oscilloscope most of us will ever see! It uses a 12-inch rectangular tube (diagonal, of course.) This is actually a "white-trace" tube, type 310DMB4, but a transparent green graticule in front of it shows the familiar green line trace. If you have never seen an i.f. response curve seven inches long and four inches high, with plenty of room to spare on all sides, this is your chance!

With its big screen, the 5121 could be used in overhead, or overbench mountings, and be seen from any position in the work area. It could even be permanently connected to the sweep generator and left on. It has an "Automatic Brightness Control" feature. Unless there is a signal being fed into the horizontal input, the trace is extinguished. When the sweep is turned on (external or line sweep/internal) the trace appears.

The vertical amplifiers in this instrument have ample sensitivity for this type of work. They go from dc to 10 kHz, at 3 dB. Sensitivity is 5 mV/cm peak-to-peak. A three-step vertical attenuator is used: DIRECT, 1/10 and CAL (ibrate). When the step attenuator is in CAL, a 100-mV p-p square-wave calibrating voltage is applied to the vertical input. The variable vertical attenuator can then be set for any desired pattern height. After this calibration is made, p-p voltages can be read directly from the graticule at any point on the curve.

The horizontal sweep has a similar attenuator; one 3-step switch, DIRECT, 1/10 and LINE SWEEP, using 60-Hz sine-wave sweep, internal. The last has a phasing control for proper adjustment of the curves, on the front panel. A variable attenuator allows the length of the trace to be set to any size needed, or expanded for closer examination of trap-notches, etc. The DIRECT and 1/10 positions are used with an external horizontal sweep, from the sweep-generator.

The ON-OFF switch, INTENSITY, and FOCUS controls are at the top of the front panel. The VERTICAL and HORIZONTAL position controls are placed in their respective areas on the front panel.

The 5121 has provisions for using an internal amplitude-modulated marker signal. This can be used for time measurement, calibration of unknown frequencies, etc., by feeding it into the Z-axis of the tube. Marker signals can be controlled in amplitude; this control is also on the front panel.

You'll notice one slightly unusual

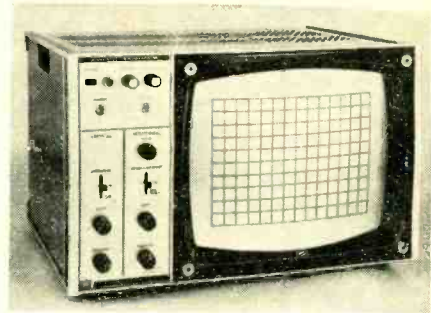

thing in the patterns on this scope; the markers. Apparently due to the reduced vertical-frequency response, the "birdie" crystal-controlled markers will not show up as a comparatively wide diamond-shaped pip as they do on wider-band scopes. They'll show only two or three "wiggles"! A full-zero-beat pattern actually starts at about 30 to 40 kHz, drops to zero, then goes back up and out. This scope actually shows only the "zero-beat" portion of the marker, but it is easy to identify and locate.

Horizontal and vertical input jacks, together with the MARKER INPUT, are BNC connectors, placed on the rear apron of the chassis. A novel and very useful feature in certain applications, is also located here. A slide switch allows selection of INTERNAL or REMOTE vertical positioning of the trace. By connecting a 5000-ohm potentiometer to the jumper plug provided, and setting the switch to REMOTE, the vertical positioning of the trace can be adjusted from any convenient location of the 5000-ohm potentiometer. This could be handy for production-line work, etc. The trace can be moved up or down, or set at a certain point for p-p readings, etc.

All circuits in the 5121 are solid state. Dc supply voltages for the amplifiers are regulated. An accelerating voltage of 8 kV is used on the CRT, giving a very bright trace. This voltage is obtained from the power transformer.

The Kikusui Alignment Scope is a product of the Kikusui Electronics Corp., Kawasaki, Japan, and is distributed in the U.S. through Marubeni-Iida (America) Inc., 200 Park Ave., New York, N.Y. 10017. **R-E**

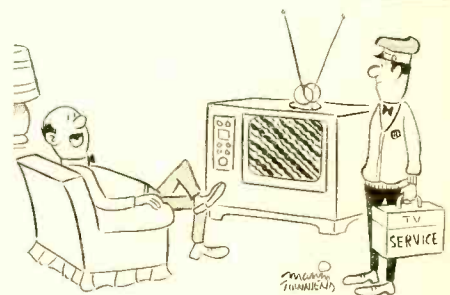

"I'm sorta' sorry you showed up so soon. It's nice watching something that's not interrupted every few minutes with a commercial!"

TRY THIS ONE

BUSINESS RADIO MIKE CHECKER

This basic microphone checker is a real timesaver for the 2-way radio technician with a heavy work load. It gives relative checks of carbon and transistorized types and, at the same time, checks the push-to-talk contacts. As the diagram shows, it consists of a meter and rectifier diode in series across the secondary of a mike transformer. Component values depend on

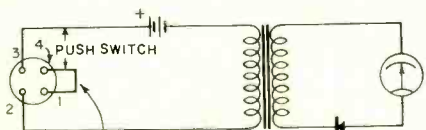

STRAP PUTS TALK SWITCH IN SERIES WITH MIKE

individual need and the availability of parts and can be determined with a minimum of experimentation. It fits in a small utility box with no switches or bothersome leads. You can add input connectors to match those on the mikes of equipment most-often-served. Strap the connector terminals so the external push-to-talk switch contacts are in series with the mike.—*David C. Black*

THEFT PROTECTION

My shop and home are together, and after the shop was burglarized once, I considered getting a watchdog, which has its disadvantages. Instead, I took one of our tape recorders and taped the vicious barks, yelps and growls of a friend's dog.

With the recorder at my bedside, at the least suspicion of prowlers, I flick it on, with full volume turned up. The recorded sounds are so convincing, from the outside, that there's a big dog on the premises, that we haven't been robbed once in the past 3 years, yet the recorder came into play four times in that period.—*H. Josephs*

SAVE THE BITS

When using hole saws to drill large holes for auto radio antennas, speakers, etc. the quarter-inch bit in the center often snaps when the bit drills through the metal.

To prevent breakage, use a quarter-inch drill and bit, drill the pilot hole in the correct spot. Then, instead of using a bit in the center of the hole saw, use a piece of quarter-inch steel rod. Taper the end slightly and drill the hole with the hole saw.—*Stanley Clark*

R-E

Clever Kleps

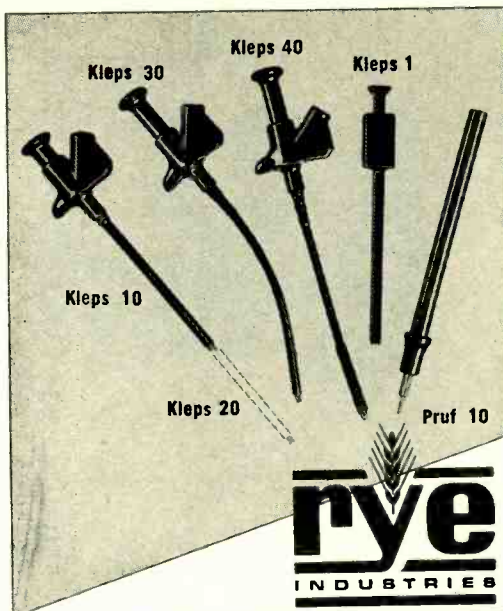

Test probes designed by your needs—Push to seize, push to release (all Kleps spring loaded).

Kleps 10. Boathook type clamp grips wires, lugs, terminals. Accepts banana plug or bare wire lead. 4¾" long. **\$1.19**

Kleps 20. Same, but 7" long. **\$1.39**

Kleps 30. Completely flexible. Forked-tongue gripper. Accepts banana plug or bare lead. 6" long. **\$1.47**

Kleps 40. Completely flexible. 3-segment automatic collet firmly grips wire ends, PC-board terminals, connector pins. Accepts banana plug or plain wire. 6¾" long. **\$2.39**

Kleps 1. Economy Kleps for light line work (not lab quality). Meshing claws. 4½" long. **\$.99**

Prof 10. Versatile test prod. Solder connection. Molded phenolic. Doubles as scribing tool. "Bunch" pin fits banana jack. Phone tip. 5½" long. **\$.79**

All in red or black — specify.

For additional information, write for our complete catalog of — test probes, plugs, sockets, connectors, earphones, headsets, and miniature components.

Available through your local distributor, or write to:
RYE INDUSTRIES, INC.

127 Spencer Place, Mamaroneck, N.Y. 10543

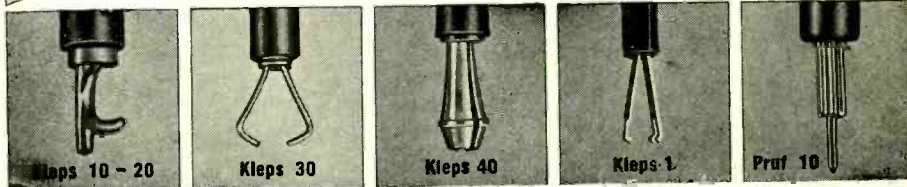

Circle 8 on reader service card

Build this pipelike Schober Recital Organ for only \$1850!*

You couldn't touch an organ like this in a store for less than \$4,000—and there never has been an electronic instrument with this vast variety of genuine pipe-organ voices that you can add to and change any time you like! All four families of formal pipe tones are present in variety to delight players of classic and religious music. Yet you can change the entire organ for popular and theatrical sounds, or plug in special voices for baroque, romantic, or modern repertoires. If you've dreamed of the sound of a large pipe organ in your own home, if you're looking for an organ for your church, you'll be more thrilled and happy with a Schober Recital Organ than you could possibly imagine—kit or no kit.

You can learn to play it—and a full-size, full-facility instrument is easier to learn on than any cut-down "home" model. And you can build it, from Schober Kits, world famous for ease of assembly without the slightest knowledge of electronics or music, for design and parts quality from the ground up, and—above all—for the highest praise from musicians everywhere.

Send right now for the full-color Schober catalog, containing specifications of all five Schober Organ models, beginning at \$499.50. No charge, no obligation. If you like music, you owe yourself a Schober Organ!

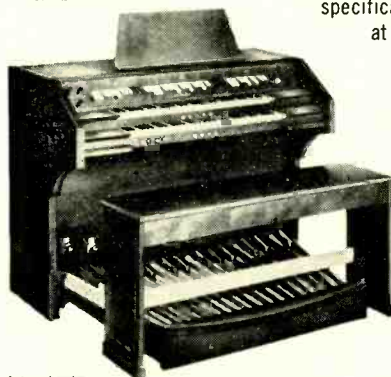

* Includes finished walnut console. (Only \$1446 if you build your own console.) Amplifier, speaker system, optional accessories extra.

Circle 9 on reader service card

The Schober Organ Corp., Dept. RE-92
43 West 61st Street, New York, N.Y. 10023

Please send me Schober Organ Catalog and free 7-inch "sample" record.

Enclosed please find \$1.00 for 12-inch L.P. record of Schober Organ music.

NAME _____

ADDRESS _____

CITY _____

STATE _____

ZIP _____

NEW PRODUCTS

More information on new products is available from the manufacturers of items identified by a Reader Service number. Use the Reader Service Card on page 81 and circle the numbers of the new products on which you would like further information. Detach and mail the postage-paid card.

SOLID STATE AMPLIFIED INDOOR ANTENNA, Chroma 1, includes vhf amplifier which makes incoming vhf TV signals 7 times stronger before they are sent to the TV set. Designed to eliminate or minimize "snow" in primary and suburban areas, the unit matches the imped-

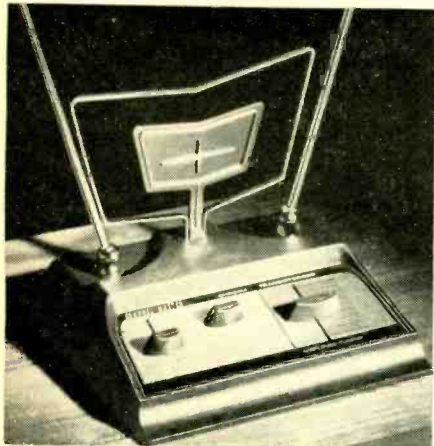

ance of the coax cable to the vhf and uhf inputs of the TV set. *Chroma 1* uses a single 75-ohm coaxial coax cable and a variable inductance tuner to trap out unwanted signals. \$21.95.—**Channel Master**, Ellenville, N.Y. 12428.

Circle 31 on reader service card

PREAMPS, models M64 and M64-2E. Two stereo preamps for operating magnetic phono cartridges and tape playback heads. Both models have single slide switch for selecting equalization for phono, tape, or flat. Positions provide RIAA for magnetic stereo cartridges,

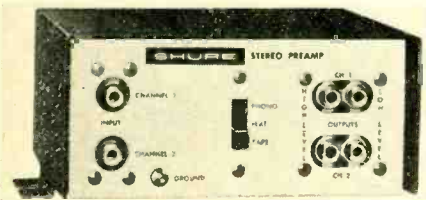

NAB for tape head equalization, and flat for microphone or for use as buffer amplifier. *M64* operates on 117 volts, 50/60 Hz power line, or from auxiliary 24 to 36-volt dc supply. *M64-2E* is identical to the *M64* except that it operates on a line voltage of 240 volts, 50/60 Hz. \$34.00 each.—**Shure Brothers, Inc.**, 222 Hartrey Ave., Evanston, Ill. 60204.

Circle 32 on reader service card

INTERFERENCE LOCATOR, model 600A, designed to detect radio-frequency sources. Unit is solid-state, with frequency range from 540 kHz to 220 MHz in 6 bands, sensitivity of 2 μ V or better, for 5% meter deflection over entire tuning range. Portable instrument measures 4- $\frac{1}{2}$ " high x 16- $\frac{1}{2}$ " wide x 11" deep, weighs

17.5 lbs., including battery. Accessories include batteries, combination dipole antenna, directional loop antenna, and carrying strap. Complete for \$688.00.—**Sprague Electric Co.**, 81 Marshall St., North Adams, Mass. 01247.



Circle 33 on reader service card

MARINE ACCESSORIES, Omniband-VI and Seacall. Multi-band radio, *Omniband-VI*, (illustrated) receives long wave, standard AM, marine, standard FM, vhf/AM aircraft, vhf/AM marine, US Weather Bureau, police, fire emergency broadcasts. *Seacall Power Hailer*, used for



voice communication between vessels, features an automatic fog horn signal, and is a listening instrument. Maximum power output of 70 watts. Both units completely solid-state.—**Unimetrics, Marine Products Div.**, 23 West Mall, Plainview, N.Y. 11803.

Circle 34 on reader service card

PA AMPLIFIERS, all-silicon, solid-state circuitry, designed for continuous operation at full output from -20° C (-4° F) to $+50^{\circ}$ C ($+122^{\circ}$ F), advanced complementary transistor circuitry. *Model C20*, 20 watts, one high-impedance microphone input. *Models C35,*

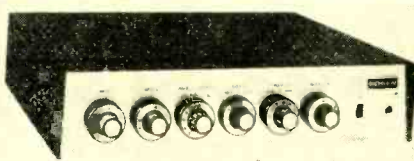

C60, and *C100*, 35, 60, and 100 watts respectively, are all identical in other features. They have two high-impedance microphone inputs. *C20*, \$132.50; *C35*,

\$162.50; *C60*, \$197.50; *C100*, \$247.50.—**Bogen Div., Lear Siegler, Inc.**, P.O. Box 500, Paramus, N.J. 07652.

Circle 35 on reader service card

ELECTROSTATIC STEREO HEADSETS, Mark III Isophase and model 5750 Dynaphase I. The *Mark III* features a protective circuit to prevent overloading, built into the system's polarizer. The headphones weigh 15 ounces and have frequency response of 20 Hz to 20 kHz. One *Mark III* headphone set and polarizer



costs \$159.95. Additional headphones are \$75.00 each. Multiphone couplers are \$9.95 each. The *model 5750* has a frequency response of 30 Hz to 18 kHz and sensitivity is 95 dB at 1 kHz for 1 mW. \$59.95.—**Stanton Magnetics Inc.**, Terminal Drive, Plainview, N.Y. 11803.

Circle 36 on reader service card

TWO-WAY SPEAKER SYSTEM, Rectilinear XI. Unit has tube-vented bass reflex; 10-inch woofer and 3-inch tweeter both extended range moving-coil types. Minimum power requirement of 10 watts (rms). Capable of handling 70 watts (IHF music power) with nearly constant 8-



ohms impedance over most of its range. Oiled walnut finish. 23" x 12" x 10 $\frac{1}{2}$ " deep. \$69.50.—**Rectilinear Research & Development Corp.**, 107 Bruckner Blvd., Bronx, N.Y. 10454.

Circle 37 on reader service card

LIGHT-EMITTING DIODE, Diode-Lite, made with gallium arsenide phosphide, a material which emits light in the red region of the electromagnetic

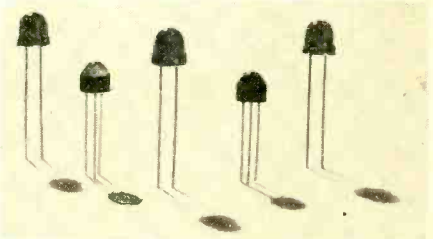

spectrum. The solid-state lights have estimated lifetimes of 100's of thousands of hours, are compatible with IC's, and shock and vibration proof. For panel

**"Hard work's
not enough...
you need more
education to
get ahead in
electronics"**

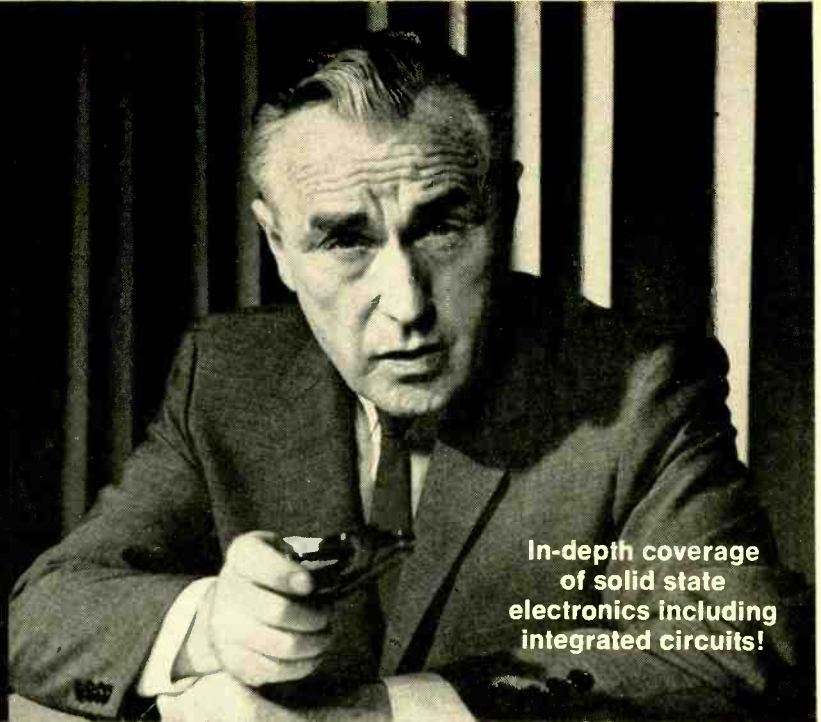

**In-depth coverage
of solid state
electronics including
integrated circuits!**

Cut along dotted line—Seal (paste or tape) and mail

Ask anyone who really knows the electronics industry. You can't hope to succeed unless you supplement your experience with specialized, up-to-date technical knowledge.

Going back to school isn't easy for a man with a full-time job and family obligations. But CREI Home Study Programs make it possible for you to get the additional education you need without attending classes. You study at home, at your own pace, on your own schedule.

CREI Programs cover all important areas of electronics including communications, automatic control, computers, even digital communications. You're sure to find a program that fits your career objectives.

FREE book gives all the facts. Mail postpaid reply coupon today or write: CREI, Dept. E1407B, 3224 Sixteenth St., N.W., Washington, D.C. 20010

Founded 1927

CREI

Accredited Member of the
National Home Study Council

**SEND FOR
FREE BOOK**

Cut out entire business reply envelope at right. Fill in coupon. Fold over, seal (paste or tape) and mail today.

NO STAMP NECESSARY.



NO STAMP NEEDED—

This entire fold-over coupon forms a postpaid envelope

Please mail me FREE book describing CREI Programs. I am employed in electronics and have a high school education.

E 1407 B

NAME _____ AGE _____

ADDRESS _____

CITY _____ STATE _____ ZIP _____

EMPLOYED BY _____

TYPE OF PRESENT WORK _____

- I am interested in: Electronic Engineering Technology
 Space Electronics Computers Nuclear Engineering Technology
 Industrial Electronics **NEW!** Electronics Systems Engineering
 NEW! Non-Technical Course in Computer Programming

Approved for training under new G.I. Bill

Do not cut here—just fold over, seal and mail—No stamp needed

FIRST CLASS
Permit No. 288-R
Washington, D.C.

BUSINESS REPLY MAIL

No Postage Stamp Necessary If Mailed In The United States

Postage will be paid by

CREI

**CREI, A Division of the McGraw-Hill
Continuing Education Company**

3224 Sixteenth St., N.W.
Washington, D.C. 20010

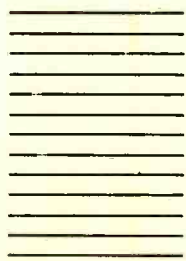

lights, film annotation, circuit-status indicators, and alpha numeric displays. Draws 50 mA at 1.8 V. \$1.55 for 1 to 9 units. —Dialight Corp., 60 Stewart Ave., Brooklyn, N.Y. 11237.

Circle 38 on reader service card

MOBILE ANTENNA SYSTEM, Rode-Master MD-1 and MD-6. Amateur system features five interchangeable coils for 10, 15, 20, 40 and 75/80 meters,

power rated for 200 watts AM; 400 watts p.e.p. SSB. Adjustable VSWR of 1.5/1 or better at any given frequency on each band. Upper mast section doubles as 6-meter whip, adjustable for

the entire band. Support mast with matching network (includes 6-meter whip), MD-1, \$18.43. Six-meter whip only, MD-6, \$5.30. Coils for 10 to 80 meters range from \$5.45 to \$13.13. —Mosley Electronics, Inc., 4610 N. Lindberg Blvd., Bridgeton, Mo. 63044.

Circle 39 on reader service card

TAPE SECURITY DEVICE. An anti-theft device, the lock kit KM26L is part

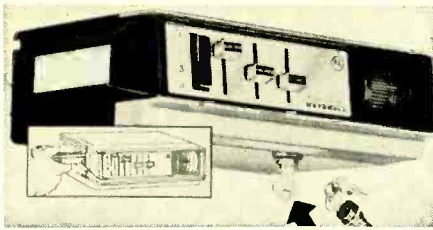

of Motorola's 1971 auto tape player line. The kit has a tubular outer casing of tool steel which cannot be readily cut or broken with ordinary tools. The lock can be inserted through Motorola's side track model TM717 (shown) or 8-track tape players to secure the unit under the dash of many autos. The locking mechanism uses a double bitted key for extra security. \$9.95. —Motorola Inc., Automotive Products Div., 9401 W. Grand Ave., Franklin Park, Ill. 60131.

Circle 40 on reader service card

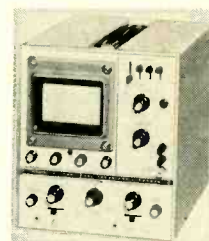

DUAL TRACE OSCILLOSCOPE, model EU70-A. Solid-state triggered sweep dc-15 MHz oscilloscope has X-Y capability. Two separate inputs can be individually displayed in Ch. 1 or Ch. 2 modes. Alternate and chopped

modes allow both signals to be displayed at once for direct comparison. Full bandwidth is provided for 20V/cm to 50 mV/cm. Features rear panel sweep gate output delivering a +5 V pulse in sync with the sweep; TTL-compatible external blanking input; 8 x 10 cm rectangular flat-face CRT with a standard camera mount on the bezel; front and rear tilt bails. \$565.00. —Heath Co., Benton Harbor, Mich. 49022.

Circle 41 on reader service card

FUSE PULLER. One-piece fuse extractor permits the user with one hand to insert and remove long or short fuses from automotive and electronic circuit

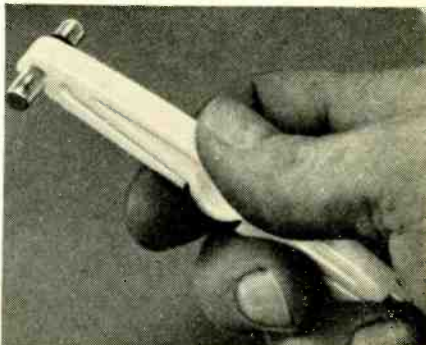

boards. The puller is molded of white nylon material, is approximately 3" long, and 1" wide at center. —Littlefuse, Inc., Dept. PR, 800 E. Northwest Hwy., Des Plaines, Ill. 60016.

Circle 42 on reader service card

CAR BURGLAR ALARM, solid state,

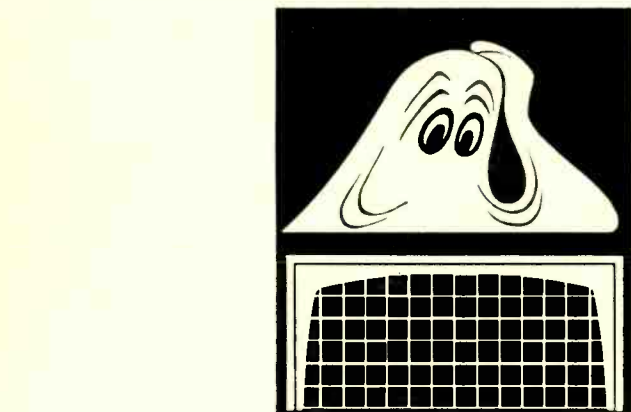
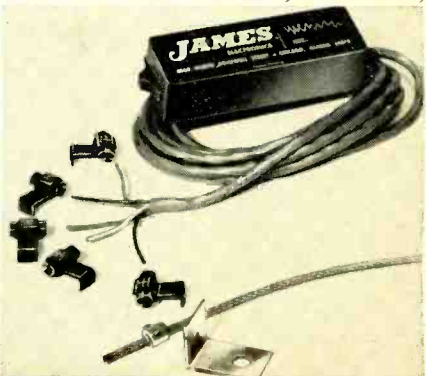

Two new B&K digitals that don't stand a chance of a ghost.

Ghosts, blurs, wiggles, jitters... whatever you call them, you won't get them with our two new digital color generators. You can converge, install or trouble-shoot color TV's quickly and accurately. Because these two units employ totally new concepts that take the trouble out of trouble-shooting.

Integrated circuit flip-flops perform all binary counting functions. Just no way they can jump a count. Result: Crisp, clean, stable test patterns.

And all IC's (nine of them) and transistors are silicon devices, which means they can withstand severe weather changes with no effect on performance.

The 1243 is a basic 6 pattern color generator. The deluxe 1246 has nine patterns, three more than the 1243, and

also features a 4½ MHz sound carrier, crystal controlled RF for channels 3 and 4, gun killers, and comes with its own instant-use case.

All the accuracy and reliability of a computer in these compact units, and they're guaranteed to be maintenance free, making your job a lot easier.

So don't get a CBG that may come back to haunt you. Get one of B&K's new digital generators: They don't have a chance of a ghost.



The new standard of stability

(Ask your distributor or write us for complete catalog)

1. B&K Model 1246 Color Generator \$149.95



2. B&K Model 1243 Color Generator \$99.95



Circle 61 on reader service card

uses existing car hardware and wiring. Unit detects any entrance and disables ignition without damaging coil. Use of supplied self-tapping electrical connectors eliminates drilling, cutting, or adjusting and makes alarm transferable from car to car. Any entrance sounds the car horn 60 times per minute for up to eight minutes and then resets. Use of car horn makes unit legal in all states. Deluxe unit has a hood/trunk cable lock assembly. *Basic alarm*, \$39.95; *Deluxe alarm*, \$49.95.—James Electronics Inc., 4050 N. Rockwell St., Chicago, Ill. 60618.

Circle 50 on reader service card

AEROSOL TAPE-HEAD CLEANER, THC-6.

Specifically formulated for cassette, video, 8-track and reel-to-reel tape recorders, this spray cleaner removes dirt, film and oxide from heads, tape guides, capstan rollers and other parts. Cleans and dries without wiping, leaving no residue. Guaranteed non-abrasive, safe for all plastics, non-flammable, non-toxic and non-conductive. Six-inch spray extender included with each 6-oz. can.—Chemtronics, Inc., 1260 Ralph Ave., B'klyn., N.Y. 11236.



Circle 51 on reader service card

(Write direct to the manufacturer for information on the following items.)

MOS/LSI/LED ELECTRONIC COUNTER SYSTEM, model 5300A, includes mainframe, choice of four functional snap-on modules including a 500-MHz counter, and a battery pack. The modules cost from \$125.00 to \$750.00, the battery pack is \$175.00, and the



mainframe is \$395.00. Autoranging, serial BCD digital output, and a high-stability crystal reference oscillator, are standard. The four modules now available are two different frequency counters, and two counter/timers.—Inquiries Manager, Hewlett-Packard Co., 1601 California Ave., Palo Alto, Calif. 94304.

CONNECTOR/POTTING KIT, model WA-3000. Using polyethylene cartridges, connector contacts and an industrial-rated heat gun with an interchangeable nozzle feature, all supplied with the kit,

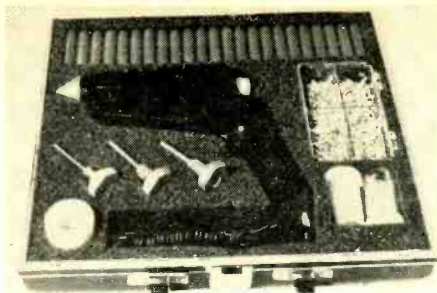

a mate can be injection-molded to most of the connector configurations that exist, in minutes, by non-technical personnel. Kit carries 48 cartridges and sufficient connector contacts for up to 20 connectors. \$98.00.—Wiring Analyzers Inc., 9015 Wilshire Blvd., Beverly Hills, Calif. 90211.

ALLIGATOR CLIPS. Completely sol-

derless alligator clip uses crimp-type connection to eliminate solder wicking, charred insulation, cold-solder joints. Designed to accept standard test lead wire, the crimp barrel includes a stress-reliev-

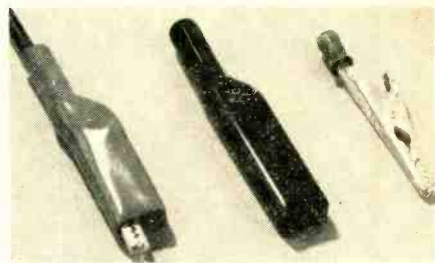

ing insulation support. Clip has serrated jaws and pre-loaded spring, and is made of corrosion-resistant cadmium-plated electrical grade copper with a steel pivot bearing.—American Pamcor, Inc., Valley Forge, Pa. 19481. R-E



Joint Venture

UNIQUE NEW WAY TO SELF EMPLOYMENT WITH EXECUTIVE LEVEL INCOME!

Get together with the world's largest electronics store chain:

\$15,000-\$20,000 GETS YOU IN BUSINESS FOR YOURSELF*

*One-time investment in physical inventory and store fixtures — no fees, no royalties, no hidden costs!

Joint Allied Radio Shack in a rare opportunity to capitalize on the zooming demand for everything in consumer electronics. First in the field, we have over 950 stores nationwide but must expand to meet the growing market (\$10 billion in 1971 alone!) and need energetic men and women to operate new or existing stores. Why not be your own boss in a Joint Venture with YOUR OWN Allied Radio Shack Store? Minimum cash needed is \$15,000-\$20,000—which represents an investment in physical inventory and store fixtures—NO fees at all! You operate as a true businessman with the profit and income potential strictly up to you!

In this Joint Venture, your success is our success—50-year-old Allied Radio Shack will train you and provide the "know-how," back you with creative merchandising, exclusive products, and the best local and national advertising in the business. You'll sell famous products available nowhere else: Allied® and Realistic® brand audio and CB, Knight-Kit® and Science Fair® electronics and hobby kits, Archer® Antennas and Radio Shack batteries to name a few—everything priced "right" for big sales, good profits for you.

Enjoy the prestige and extra security of being associated with the Tandy Corporation (parent company of Allied Radio Shack), rated "Number One" in the nation in annual sales growth and earnings per share among firms in retailing (Forbes Magazine, 23rd Annual Report on American Industry). If you want to win with a winner and start a lucrative career today, act NOW.

- ★ PROFITS
- ★ SECURITY
- ★ PRESTIGE
- ★

CALL COLLECT OR WRITE:

A. A. Bernabei
Vice President
Allied Radio Shack
2617 West 7th St.
Fort Worth, Texas 76107
Phone (817) 336-7163.

SEND ME FULL JOINT VENTURE DETAILS Dept. JV-9

Name _____ Phone _____

Street _____

City _____ State _____ Zip _____

The RCA portable color bar generator



Performs like the big ones Costs only \$75*

- Provides color bar, dot, cross hatch, and blank raster patterns
- All solid state circuitry including ICs
- Pattern signals, RF output frequency and color subcarrier all crystal-controlled
- Battery operated, AC adapter available
- Lightweight — less than 20 oz., only 6½" wide x 4" deep x 3" high

For all the technical specs get in touch with your RCA Distributor. RCA | Electronic Components | Harrison, N.J. 07029.

* Optional User Price

RCA

Circle 62 on reader service card

NEW LITERATURE

All booklets catalogs, charts, data sheets and other literature listed here with a Reader's Service number are free for the asking. Turn to the Reader Service Card on page 81 and circle the numbers of the items you want. Then detach and mail the card. No postage required!

TEST INSTRUMENT CATALOG, 1971, gives photographs and specifications on over fifty test instruments and accessories. Twenty page catalog includes digital-clock binary-countdown color bar pattern generators, solid-state oscilloscopes/vectorscopes; sweep marker; field strength meter and CRT high voltage probe and meter; transistor-checker/tracers, grid dip meters and assorted accessories.—**Leader Instruments Corp.**, 37-27-27th St., L.I.C., N.Y. 11101.

Circle 43 on reader service card

RECORD CARE EQUIPMENT BROCHURE, with photographs of record care products such as cleaning tools, anti-static fluids, brushes, stylus cleaning pads, along with two booklets revealing methods for obtaining optimum reproduction from records.—**Elpa Marketing Industries, Inc.**, New Hyde Park, N.Y. 11040.

Circle 44 on reader service card

KIT & PRODUCT CATALOG, 1971. 250 products, both kit and wired form, displayed in 32-page catalog. Stereo hi-fi kits, 2-hour project kits, strobe lights, audio-color organs, solid state test equipment, accessory probes for oscilloscopes and vtvm's are featured with photos and specific.—**EICO Electronic Instrument Co., Inc.**, 283 Malta St., B'klyn., N.Y. 11207.

Circle 45 on reader service card

ANTENNA BROCHURE. Pictures and specifications for entire line of replacement antenna rods for portable TV's.—**Russell Industries, Inc.**, 96 Station Plaza, Lynbrook, N.Y. 11563.

Circle 46 on reader service card

10TH YEAR SALE CATALOG, 40 pages of items on sale. Includes picture tubes, headphones, mikes, cassettes, multimeter, transistors, precision tool kit, diode/rectifiers, soldering iron and gun, blades, batteries.—**Cornell Electronics Co.**, 4217 University Ave., San Diego, Calif. 92105.

Circle 47 on reader service card

MSI SPECIFICATIONS HANDBOOK, DCL Vol. II, Series 8000 Designer's Choice Logic. For digital system designers, both this and Vol. I, *DCL Specifications Handbook*, provide illustrated specifications, descriptions and typical applications of medium-scale integrated circuits.—**Sigmetics Corp.**, 811 E. Arques Ave., Sunnyvale, Calif. 94086.

Circle 48 on reader service card

LOUDSPEAKER SYSTEM, KLH-32. Descriptive brochure contains complete specifications on this acoustic suspension speaker system. Includes scope pic of transient response of speaker system.—**KLH Research and Development Corp.**, 30 Cross St., Cambridge, Mass. 02139.

Circle 49 on reader service card

Write direct to the manufacturers for information on items listed below:

ELECTRONIC CIRCUIT HARDWARE CATALOG contains technical data on 52 circuit design and breadboarding hardware items. Describes solderless plug-in terminal and distribution strips; IC test clips for attachment to test probes; digital test probes; dual-in-line connectors; and several sizes of pins, sockets, and harness assemblies for connecting in-circuit, circuit-to-circuit, and circuit-to-test equipment. Request catalog on company stationery.—**Mrs. W. J. Pennington, AP Inc.**, 72 Corwin Dr., Painesville, Ohio 44077.

ELECTRONICS, TECHNIPAC, AND YOU, a brochure exploring the scope of careers in electronics, the need for trained personnel, and the Technipac System of home study for the beginner and those with some experience in electronics.—**Technical Training International, Mr. G. C. Badley**, P.O. Box 4627, Walnut Creek, Calif. 94596.

R-E

R-E's SERVICE CLINIC

vertical sweep circuit troubles

Height control, vertical linearity control, feedback loop and the mysterious VDR

By JACK DAAR
SERVICE EDITOR

LAST MONTH WE FOUND A CONTROL GOING under two different names. This time we'll see another one. An obviously suspicious pair of characters! Fig. 1 shows more of the same circuit, with the other control, and the rest of the little gubbins added. You will find minor modifications of this (a Magnavox 921, 933, etc.) but they'll all be recognizable, and they all work on the same principles.

The vertical height (size control)

The new control is connected to the grid of the output stage. Through voltage divider action from $B+ 405$ volts, it adjusts the bias on the grid, and so controls the gain of this tube. This in turn controls the height of the raster. So this one is found under the name VERTICAL HEIGHT CONTROL.

In normal operation this grid has a pulse of at least 100 volts p-p on it. So it develops a good-sized negative bias by grid-leak action. This tends to cut down on the output. Some positive voltage is added through the HEIGHT control, to cancel a little of this negative voltage and keep the tube working at high output. (There's another one coming up in a minute in the same circuit)

False names and adjustments

The VERTICAL LINEARITY control varies the charging time of the .039- μ F

capacitor, the saw-former. It does control the linearity. Of course, it also varies the plate voltage of the input section. It also affects the vertical size (height). That's why you find this control marked VERTICAL SIZE in some sets.

The VERTICAL HEIGHT control also has quite an effect on vertical linearity! So in some sets, you'll see this one marked VERTICAL LINEARITY! Don't let this confuse you. As long as you've got one of each, go right ahead. Actually, you will have to adjust both of them to get the raster to the necessary "full and linear" condition.

The feedback loop

Across the top of Fig. 1, you see what looks like a very complex circuit. T'ain't. This is the feedback loop that makes the circuit oscillate. It picks up a high-voltage pulse, 800 to 1,000 volts p-p, at the plate of the output section, then simply cuts it down and shapes it up a little, then feeds it back to the grid of the input section. Its basic action is exactly like that of a vertical integrator.

The mysterious VDR.

There is one new part in there. It is found in a lot of late-model sets, especially the wide-angle deflection types. It is the VDR or Voltage-Dependent Resistor. This special resistor is made of a semiconductor material that has the odd property of *changing* its resistance in re-

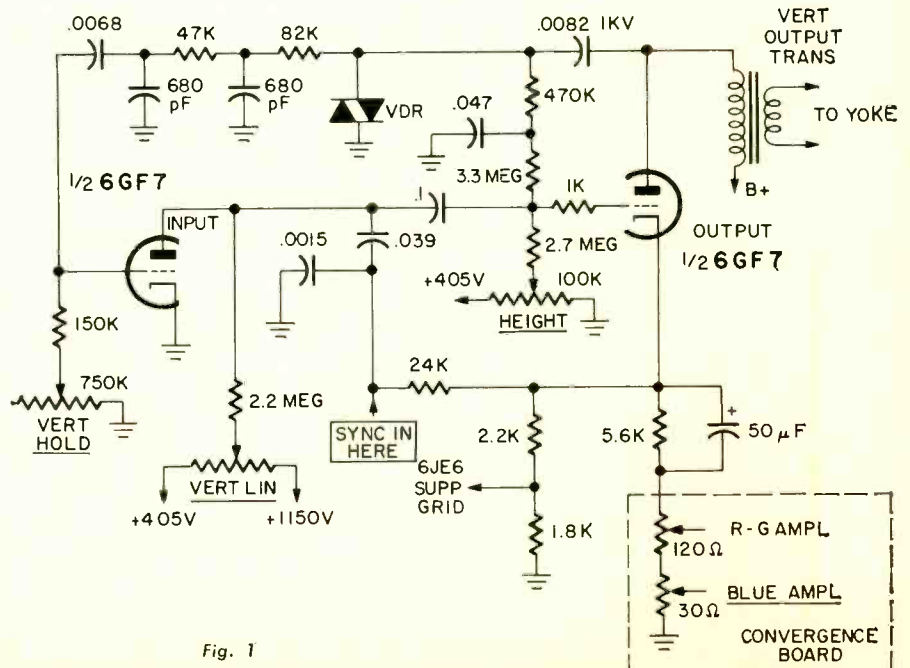

Fig. 1

This column is for your service problems—TV, radio, audio or general and industrial electronics. We answer all questions individually by mail, free of charge, and the more interesting ones will be printed here.

If you're really stuck, write us. We'll do our best to help you. Don't forget to enclose a stamped, self-addressed envelope. Write: Service Editor, Radio-Electronics, 200 Park Ave. South, New York 10003.

Express Yourself
in creative electronics

EICO '71



Top Engineering
at Lowest Cost since 1945.

FREE!

32-page 25th Anniversary Catalog.
KITS & WIRED

Build all-professional Eico Kits and save 50%. The more you know about electronics, the more you appreciate Eico. Over 2500 local Eico dealers offer you all the top brands, personal technical counsel, fast off-the-shelf service.

- **SOUND N' COLOR**® high fidelity color organs, translators, strobes.
- **TEST EQUIPMENT:** new solid state instruments guaranteed 5 years.
- **CORTINA**® solid state stereo receivers, amplifiers, tuners.
- **EICOCRAFT**® solid state jiffy project electronic kits.

Write for **FREE** catalog to: EICO Electronic Instrument Co., Inc., 283 Malta St., Bklyn, N.Y. 11207. (212) 949-1100.

Circle 63 on reader service card

ELECTRONIC TECHNICIANS!

Raise your professional standing and prepare for promotion! Win your diploma in

ENGINEERING MATHEMATICS

from the Indiana Home Study Institute

We are proud to announce two great new courses in Engineering Mathematics for the electronic industry.

These unusual courses are the result of many years of study and thought by the President of Indiana Home Study, who has personally lectured in the classroom to thousands of men, from all walks of life, on mathematics, and electrical and electronic engineering.

You will have to see the lessons to appreciate them!

NOW you can master engineering mathematics and actually enjoy doing it!

WE ARE THIS SURE: you sign no contracts—you order your lessons on a money-back guarantee.

In plain language, if you aren't satisfied you don't pay, and there are no strings attached.

Write today for more information and your outline of courses.

You have nothing to lose, and everything to gain!

The INDIANA HOME STUDY INSTITUTE

Dept. RE-7, P.O. Box 1189, Panama City, Fla. 32401

Circle 64 on reader service card

lation to the voltage across it. Unlike the thermistor (which goes down in resistance as the current through it increases) the reaction of the VDR is very fast. It can change resistance in a fraction of a second. The higher the voltage, the lower the resistance. This reaction is used as a regulator in many circuits.

In this one, during retrace time the high-voltage pulse shows up on the plate side of the .0082- μ F capacitor (positive). The VDR is shunted across the other side of this capacitor. When the high voltage appears, its resistance goes down; so the capacitor charges to a high voltage. The pulse, during this time, is "fed through" the capacitor and on to the other parts in the feedback loop.

After the pulse passes, there is a "sweep-time" period when the voltage on the grid of the output tube must rise slowly in a very linear way (the "saw-tooth" part). The capacitor discharges slowly through those two big resistors, 470,000 and 3.3 megohms, to the output stage grid. This negative voltage also helps cancel some of that positive voltage being fed in by the HEIGHT control. The end result of all these actions is to improve vertical linearity.

It also regulates the output. If the line voltage rises, the B+ goes up with it, and the positive spike gets bigger. The raster would be overscanned if not controlled. The higher voltage of the spike, though, reduces the VDR's resistance, and the .0082- μ F capacitor charges to a more negative value! This, applied to the grid of the output stage, holds down the output, and the raster stays the same size.

Testing the VDR.

Because of their peculiar characteristics, VDR's are hard to test with ohmmeters, etc. (In fact, it's impossible!) You can make a test setup, with a high-voltage supply, dc milliammeter, and so on, but substitution is a lot faster.

If you suspect the VDR is causing trouble, which is rare, but always possible, there's a rough check you can make. The only problem would be a shorted VDR. If it opens, you'll have overscan, and not so much regulation. Disconnect one end of the VDR and tack a 1-megohm resistor in its place. If the VDR was defective, the raster will fill out, and you may see some overscan. No regulation, of course. Replace with an exact replacement.

(More on vertical sweep next time)

WIRELESS REMOTE FOR PA SYSTEM?

I'd like to make a wireless remote control for a PA system. This is one of those "console-on-casters" type, which makes it hard to follow around! Who makes such items?—A. A., Lansing, Mich.

Right now, I don't know of anyone making a wireless remote control specifically for PA systems. (Someone will write me an indignant letter inside of 3 days and tell me they've been

the tape that turned the cassette into a high-fidelity medium

TDK

Until TDK developed gamma ferric oxide, cassette recorders were fine for taping lectures, conferences, verbal memos and family fun—but not for serious high fidelity.

Today you can choose among high-quality stereo cassette decks.



TDK SUPER DYNAMIC (SD) TAPE



The new magnetic oxide used in TDK Super Dynamic tape distinctively differs from standard formulations in such important properties as coercive force, hysteresis-loop squareness, average particle length (only 0.4 micron!) and particle width/length ratio. These add up to meaningful performance differences: response capability from 30 to 20,000 Hz, drastically reduced background hiss, higher output level, decreased distortion and expanded dynamic range. In response alone, there's about 4 to 10 db more output in the region above 10,000 Hz—and this is immediately evident on any cassette recorder, including older types not designed for high performance. There's a difference in clarity and crispness you can hear.

Available in C60SD and C90SD lengths.

TDK ELECTRONICS CORP.
LONG ISLAND CITY, NEW YORK 11103

Circle 65 on reader service card

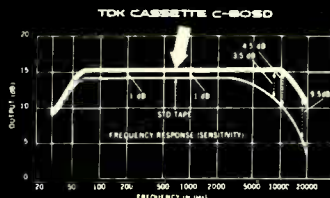

building 'em for 30 years.)

I believe your best bet, economically, would be to locate a junk TV set with an ultrasonic remote control system; or if you're feeling flush, go and buy the remote control system from the distributor! There are quite a few makes which have very reliable ultrasonic remote control systems, with compact, hand-held transmitters, and transistorized receivers. These have volume controls "already built-in" and it would be a simple job to convert one for PA work.

**HEATHKIT VTVM:
NO AC VOLTS READING**

My Heathkit vtvm won't read ac voltages. All other functions are ok. I need information. Uses 12AU7 and 6H6 tubes.—D.N., Belle Plaine Kan.

I wish you'd thought to send the model number! Anyhow, it won't be too hard to find this trouble. If the dc volts and ohms scales are working, your "metering tube," the 12AU7, is ok. This circuit actually reads nothing but dc. One grid is grounded and the

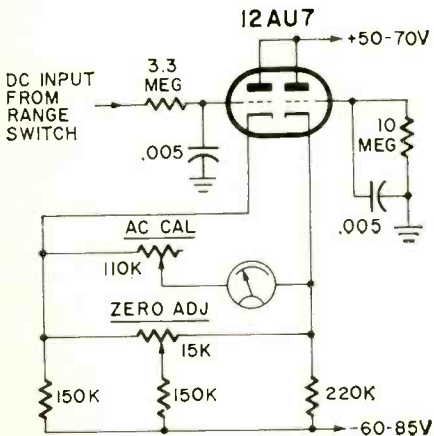

FIG. 1

voltage applied to the other. The meter is connected between the cathodes (Fig. 1). This is a standard vtvm circuit used in a great many Heathkit vtvm's (and others).

Yours uses a 6H6 tube. This is

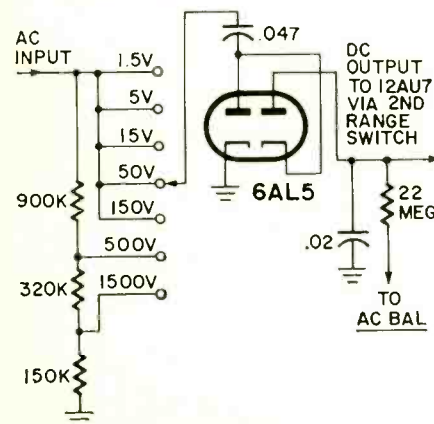

FIG. 2

an older version of the 6AL5 shown here. However, the "action" is the

ANNOUNCING

An All New MIGHTY MITE Tube Tester

Now Checks more tubes and it's faster than ever before with

- all solid state FET circuitry for instant-on action . . . first time in tube tester history
- New solid action push button function switches to speed up every test



Here is the latest version of the famous Sencore Mighty Mite tube tester; it's updated and streamlined in appearance and performance. No more wasted time waiting for the tube tester to warm up when you have a hot troublesome tube in your hand ready to test. The TC154 Mighty Mite VI is instant-on with no meter drift. New FET circuitry still enables you to read grid leakage up to 100 megohms because it too is a high impedance device like a vacuum tube. New circuitry permits even higher sensitivity check on heater to cathode leakage; from 180,000 ohms to 300,000 ohms. The Mighty Mite still checks for shorts between each and every tube element with the famous stethoscope shorts check. New two-toned vinyl-covered and brushed steel presents a truly professional instrument. See your Sencore distributor today and ask him for the new all solid state Mighty Mite. Only Sencore has it.

Over 60,000 Mighty Mites now in use.

Only \$99.50



SENCORE

NO. 1 MANUFACTURER OF ELECTRONIC MAINTENANCE EQUIPMENT

3200 Sencore Drive, Sioux Falls, So. Dakota 57107

Circle 66 on reader service card

**Unusual
tools, hard-
to-find items.
Send for
free catalog!**

Diversified collection—
tools of all kinds
precision instruments
essential shop items
... convenient
one-stop shopping
from your desk.



NC Flasher
National Camera
Dept. GBA
Englewood, Colorado, 80110

Circle 67 on reader service card

MOTOR SPEED & LIGHTING CONTROL

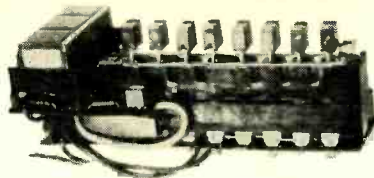

8 Push button controls, stop & start indicator lights. Overrun of famous blender manufacturer. Used for controlling speed of drills, saws, fans, lathes, lighting etc. Controls up to 1500 watts. Stock No. B5002 ready to use. 3.95 ea. 2/7.00 Stock No. B5003 slight factory seconds, easily repaired, 2.95 ea. 2/5.00 Wiring diagram furnished.

HONEYWELL COMPUTER BOARDS

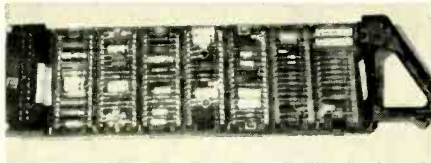

Honeywell Computer boards, 4 1/2" x 12". Transistors, diodes, zeners, capacitors, precision resistors, heat sink, trimmers etc. 2 Different boards \$1.00. 3 lb. Stock No. B9082 Honeywell Boards 5 1/2" x 6". Loaded with late no. transistors, diodes, resistors and capacitors. 2 different boards \$1.25. 2 lb. Stock No. B9094

COMPUTER GRADE CAPACITORS

B2049 3500 Mfd. 55 volt 4 1/4" x 1 3/4" \$.65 ea. 5/\$3.00
B2062 40,000 Mfd. 10 volt 3" x 4 1/4" Brand new \$1.25 ea. 6/\$7.00

**\$1.00 FREE WITH \$10.00 ORDER
MINIMUM ORDER \$3.00**

Lots of other items—send for free flyer; all merchandise fully guaranteed. Please include postage; excess will be refunded.

DELTA ELECTRONICS CO.
BOX 1, LYNN, MASSACHUSETTS 01903
Circle 68 on reader service card

same. The dual-diode tube rectifies the ac voltage and then applies it to the input grid of the 12AU7, (Fig. 2). Some of the multipliers have been omitted for clarity.

So, all you have left is the few parts in the rectifier circuit and the switching. These can be checked out with an ohmmeter or by substitution. That's all.

**NO REMOTE CONTROL,
RCA CTC 31**

The remote control on this RCA CTC 31 won't operate at all. I suspect that the transmitter box has been dropped at some time. Don't have a schematic on this one. However, I checked voltage on the battery, and there is absolutely no drop when the button is pushed.—R. H., South St. Paul, Minnesota.

I'll go along with you on that. The transmitter is probably not working at all, if you have no voltage drop on the battery. Normally you'll see a small drop, even with a brand new battery.

This is a single-transistor oscillator, operating between 34,250 and 44,750 Hz. You can check it out on any service-type scope. Use a direct probe. If you do get signals from the transistor, but no output from the transmitter, the transducer may have been damaged. If there is ultrasonic signal on the transducer terminals, but no output, the transducer is bad. (Definite check: read the signals on the receiver amplifier stages.)

TOO MUCH DC

I have a sound problem on a GE M6 chassis. I read +600 volts on the plate of the 6CU5 audio output tube, and also on the +260 volt dc source! The picture is good, but the sound channel is completely dead. What could this high voltage be coming from?—L. C., Miami, Fla.

I have a distinct feeling that you're using the same method of voltage measurement I did, no later than yesterday! On the collector of the horizontal output transistor in a little solid-state set, I read +175 volts! (Normal, +63 V.) I had a picture, HV, etc. and the current was slightly below normal. In a minute, I found that I was reading the voltage with my vom switch set on AC VOLTS! (I was reading the peak pulse voltage!)

You *must* be doing something like this. If you do have a good picture, etc., the B+ voltage is not 600 volts—it couldn't be! Check your meter setting; if it isn't set on p-p volts ac, you have problems in your dc voltage scale multipliers! Check the meter by reading a known dc voltage, or comparing it with another dc voltmeter.

R-E

Low Cost, Compact Oscilloscope

If shelf space is critical, and budgets are small—you have 2 reasons for choosing a KIKUSUI oscilloscope!

1-7 1/2" high, 5 1/2" wide, 14" deep

2-ONLY \$183⁰⁰ complete

Compare these features:

- Solid state circuitry
- High sensitivity of 20 mv/cm
- Bandwidth of 1.5 MHz
- Controls grouped by function for easy operation
- AC/DC coupled
- Flat 3 inch CRT face for sharper traces
- 3 step attenuator with variable control
- Excellent for lab or field use



Model 536A

Full line of electronic test instruments include: trigger, dual trace trigger, alignment and standard oscilloscopes.

Call or write for FREE specification catalog



kikusui
ELECTRONICS CORP.

Address all inquiries to:
Marubeni-lida (America) Inc.
200 Park Avenue, New York, N. Y. 10017
Telephone 212-973-7152

Circle 69 on reader service card

HOME VIDEO RECORDING
(continued from page 15)

explained. If you don't mind changing heads more often, then CrO₂ might be the answer. But if you've ever changed heads in a helical video recorder, chances are you'll opt for softer oxides.

Another, often overlooked problem with chromium dioxide is its low Curie point—about 120°F. Above this temperature, the oxide's magnetic domains lose their alignment and goodbye to whatever was recorded on that tape. We might call it a very impermanent recording medium.

In the meantime, several manufacturers have put their bets on improved ferric oxides and cobalt-doped ferrics with smaller-than-usual domain size. The smaller domains are nice; a wider frequency range is possible if the heads are up to the task. Some home video equipment is being designed specifically for certain of these new oxides. Philips introduced its first chromium dioxide entry two years ago—a 1/2-inch helical machine aimed at the educational market. We can't help but wonder what the instruction manual says about tape storage conditions.

And now a totally new tape coating has come along that may obsolete all the equipment designs that have been made to date. Called "Cobaloy," the new sub-micron size particle is a metal alloy instead of an oxide as is the usual case. This particle can pack so much information into a length of tape (in the computer industry, it's called "high-density storage") that Graham Magnetics, its developer, is talking about a four-fold reduction in tape speed. If this is really feasible for home video recorders, then a cassette loaded for 60 minutes of playing time at 7 1/2 ips could run for four hours at 1 7/8 ips. While this product hasn't been publicly demonstrated yet, samples will be available to the industry by late summer—after everyone's finished designing their new home video systems.

Another important feature of Cobaloy is its high coercivity—1,000 oersteds. This figure represents the amount of magnetic flux needed to dislodge the domains for erasure and re-recording. So far, the highest coercivity has been available in cobalt-doped ferric oxide—logged in at 390 oersteds. The magic number for contact tape duplication is 400, so Cobaloy qualifies as a master tape.

High-speed contact duplication has been under development for quite some time. The technique is basically very simple: a master recorded tape of high coercivity is pressed against a blank tape of relatively low coercivity. The two pass through the field of a permanent magnet. This magnetic field disturbs the domain alignment in the low coercivity tape, and when the tapes pass out of the field, tape B's domains align themselves the same way as those of the master tape. The master tape must have sufficiently high coercivity so its own magnetic alignment isn't disturbed by the magnetic field.

Without contact duplication, video cassette reproduction is chained to conventional same-speed master/slave playback. A high-quality master tape plays and 10 or 20 slave recorders connected to it dutifully duplicate the program on blank cartridges. A 60-minute program takes 60 minutes to dub. With the contact method, a 60-minute program can be duplicated in about six minutes.

Many major hardware manufacturers are putting their reputations and money on the line for a home market that may well surpass the most optimistic estimates. According to educated guesses by industry spokesmen, the home market by 1976 will amount to some \$200-\$300 millions out of a total worldwide video recording market of \$640-\$850 millions. Even at the low end of this projected sale scale, the home video recording market is a tempting plum indeed. And who knows? Perhaps at long last we'll see a true home VTR at a price everyone can afford. **R-E**

Allied Radio Shack Eliminates Expensive Auto Tune-Ups!



49⁹⁵
POSTPAID

For ANY Car! Portable!
Fun to Build! Easy to Use!

Do it Yourself with Our **knight-kit**[®]
Universal Auto Analyzer Kit!

Cut car costs—do your own maintenance and troubleshooting. Keep engines in perfect tune—with this low-cost electronic kit! It has a built-in tachometer, dwell meter, ammeter, ohmmeter, voltmeter and leakage tester. Check out electrical/ignition systems, set idling speed and timing, test spark plugs and points, and more! One easy reading 7 1/2" meter for all tests! Solid-state circuitry, battery powered, 100% self-contained. Includes step-by-step assembly instructions, operating manual, 48-page tune-up guide for U.S. cars/trucks and many foreign makes, 4 "C" batteries, 1000's in use! Available at Allied Radio Shack stores everywhere or by mail.

Over 950 Stores Nationwide See the Yellow Pages



FREE!
Parts/Kit
Catalog

Electronics
for Everyone!

Dept. RE-2

ALLIED RADIO SHACK

A TANDY CORPORATION COMPANY

2725 W. 7th Street
Fort Worth, Texas 76107

Knight-Kit Auto Analyzer @ 49.95 Postpaid

FREE 1971 Parts/Kit Catalog

Name (print) _____

Apt. No. _____ Route _____ Box _____

Street _____

City _____ State _____ Zip _____

"SUPER" IS THE WORD FOR WORKMAN COLOR TV CRT BRIGHTENERS

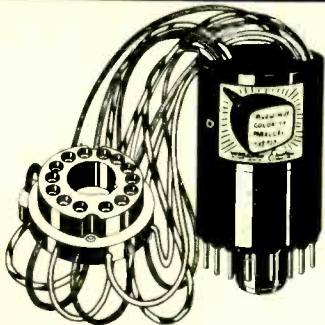

WE START WITH A STURDY MOLDED PLASTIC CASE. NOW WE FILL IT WITH A HEAVY DUTY TRANSFORMER. THIS WILL DELIVER THE HIGHEST POSSIBLE VOLTAGE FOR MAXIMUM BRIGHTNESS. OUR SUPER-BRIGHTENER WILL STAY COOL FOR LONGER-LASTING, EFFICIENT PERFORMANCE.

ASK FOR OUR COMPLETE LINE OF BRIGHTENERS IN A FREE VEST POCKET SIZE CROSS REFERENCE No. X62.

MANUFACTURED BY
WORKMAN Electronic
P.O. BOX 3828 SARASOTA, FLORIDA 33578
PRODUCTS, INC.

Circle 70 on reader service card

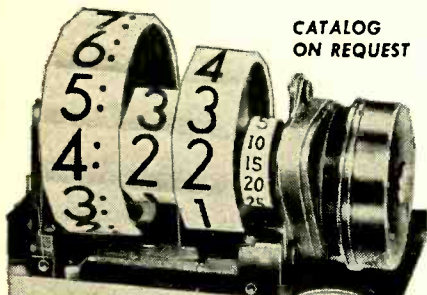

CATALOG ON REQUEST



DIGITAL CLOCK MOVEMENTS

DIGITS RESETTABLE INDIVIDUALLY

Available in 50, 60 cy., all voltages. AC. UL approved motor, card. One Year Guarantee.

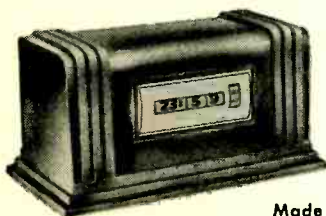

#100-24H
24 Hour
CLOCK

Made in U.S.A.

Complete Line: Delay, Interval and Cycle Timers, Digital Computers

PENNDOWN NUMECHRON CO.
TYMETER ELECTRONICS

7249 FRANKSTOWN AVE. PITTSBURGH, PA 15208

Circle 71 on reader service card

DESIGN FOR STEREO (continued from page 45)

age gain is to be more than '1', the CC circuit is not usable. The requirement of a fairly high input impedance makes the CB circuit impractical. We must then turn to the remaining CE arrangement of Fig. 2. You will find this circuit the most practical in many designs because of its gain and impedance characteristics.

Turn to the cartridge for the next consideration. The average output from the new cartridge is 2 mV. The peak output from the cartridge may be as much as ten times this value or 20 mV. Across the 4,700-ohm load resistor, R_C , of the amplifier stage, the output voltage must be capable of swinging $(\pm 20 \text{ mV}) \times 3 = \pm 60 \text{ mV}$. (As you recall, the gain of the stage must be at least 3). The minimum collector current swing is then $60 \text{ mV} / 4,700 \text{ ohms} = 12 \mu\text{A}$. Low-noise considerations dictate that the collector bias current and voltage be very small. On the other hand, low distortion requires that the quiescent current and voltage be out of the leakage = current and saturation regions of the collector characteristic curves. A good compromise is to use the idling conditions of $V_{CE} = 2 \text{ volts}$ and $I_C = 0.5 \text{ mA}$. The quiescent voltage across R_C is then $0.5 \text{ mA} \times 4,700 \text{ ohms} = 2.35 \text{ volts}$.

Leakage current is no factor so the bias circuit can be very simple. The circuit in Fig. 9 can be used. The compo-

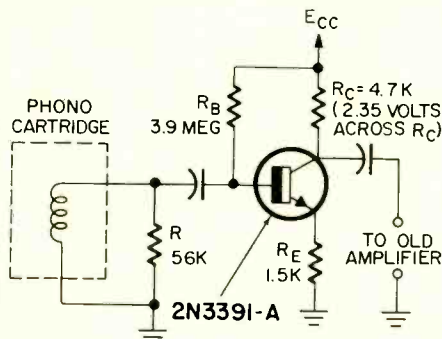

FIG. 9—PHONO PREAMP designed to give new life to an old audio amplifier.

nents and characteristics we have already determined are noted in the drawing.

An idling current of 0.5 mA means that the ac emitter resistance in the transistor is $r_e = 26/I_E$ (see above), or equal to 52 ohms. To have a voltage gain of 3, $R_E + r_e = R_C/3$ (see Equation 3), so that $R_E + r_e = 4700/3 = 1567 \text{ ohms}$. Subtracting $r_e = 52 \text{ ohms}$, and using the nearest EIA resistor value, we will make $R_E = 1500 \text{ ohms}$.

The idling voltage across $R_E = (1500 \text{ ohms}) (0.5 \text{ mA}) = 0.75 \text{ volts}$, for $I_E \approx I_C$. The supply voltage, E_{CC} , is equal to the sum of the quiescent voltages across R_E and R_C plus V_{CE} , or $0.75 + 2.35 + 2 = 5.05 \text{ volts}$. Use a 6-volt battery for E_{CC} to power the circuit.

The bias resistor, R_B , can now be determined. The base current is the collector current, 0.5 mA, divided by the average beta of the 2N3391-A, or 400. Doing the arithmetic, it is 1.25 mA ($1.25 \times 10^{-6} \text{ Amperes}$). The current flowing through the base-emitter junction is E_{CC} divided by the sum of R_B and R_E reflect-

ed into the base circuit. By Ohm's law

$$1.25 \times 10^{-6} = \frac{6 - 0.6}{R_B + \beta R_E}$$

$$\text{(letting } V_{BE} = 0.6 \text{ volts)}$$

$$1.25 \times 10^{-6} [R_B + 400 (1500)] = 6 - 0.6$$

Solving for R_B , it is equal to $3.72 \times 10^6 \text{ ohms}$. Use the EIA standard 3.9-megohm resistor.

The minimum overall resistance of the base circuit should now be calculated. If this resistance is more than the required 47,000 ohms the cartridge must see, place a resistor across the cartridge parallel to the base resistance. The combination of this resistor in parallel with the base circuit resistance must equal about 47,000 ohms.

The impedance reflected into the base due to $r_e + R_E$ for the minimum beta of 250 for the 2N3391-A transistor, is $250 (1500 + 52) = 387,500 \text{ ohms}$. The cartridge sees this resistance in parallel with R_B , or approximately 350,000 ohms. If the cartridge is to see 47,000 ohms, a resistor must be shunted across the cartridge to parallel the 350,000 ohms. Using the usual equation for parallel resistors (R_p is equal to the resistance of the two resistors, R and R_1 connected in parallel),

$$\frac{1}{R_p} = \frac{1}{R} + \frac{1}{R_1} \text{ or } R_p = \frac{RR_1}{R + R_1} \quad \text{Eq. 21}$$

we can calculate the resistor to be placed across the cartridge. Substituting component values, Equation 21 becomes

$$47,000 = (350,000 R) / 350 + R$$

R is equal to 54,000 ohms. Use a 56,000 ohms 10% EIA resistor.

Output impedance as well as current and power gains are not important in this problem. The gains can easily be calculated by substituting the numbers into Equations 4 and 5, as follows.

$$A_1 = \beta = 400 \text{ (ranging from 250 to 500)}$$

$$G = A_1 A_v = 400 \times 3 = 1200$$

R_{OUT} is more difficult to calculate as transistor manufacturers do not supply all the data required for substitution into the equation. However, the old implifier sees the collector load resistor, R_C , of the single stage, shunting R_{OUT} . As far as the old amplifier is concerned, this stage has an output impedance of about 4,700 ohms because R_C is much smaller than R_{OUT} .

Noise and frequency response

High-gain input stages must have excellent noise characteristics to be acceptable. A study of this for bipolar and FET devices will be next.

Frequency characteristics will also be discussed in the future. The significance of this is most important when designing high impedance FET circuits or when using the large power bipolar devices. **R-E**

Superstitious technician named Dean checked a set just before Halloween. It belonged to a witch, and her nose gave a twitch, Now the set works but Dean has turned green.

Jack Darr

COMING NEXT MONTH

AUGUST 1971

■ **All about Probes**

We all use probes with our test equipment. Here's an in-depth article on how these devices tick, what they will and won't do for you, and how to use them properly.

■ **2 Dream Workbenches**

One for the service technician; the other for the R-E experimenter. Equipment, bench layout, accessories; all are detailed, along with tips on where to use the gear.

■ **Using The Tone-Burst Generator**

A follow-up on the article on how to build a tone-burst generator that appears on page 22 in this issue. See how to put the generator to work in your shop.

PLUS:

Jack Darr's Appliance
Electronics Clinic
Inside A Light Show
More Alarm Circuits
Tail-Light Indicator



Win Fabulous Free Gifts selling up to JERROLD antennas & systems

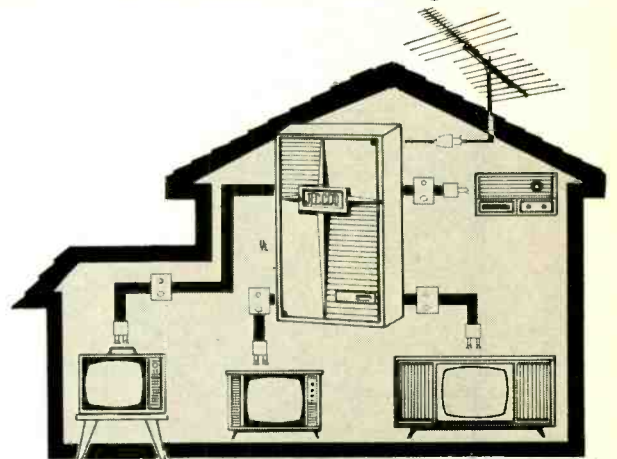

Spectrum '71 is designed to focus your attention on the broad spectrum of JERROLD high profit "better reception" products. When you sell up to the best in antennas and Master Antenna TV systems, you earn more profit... plus fabulous free gifts.

Ask your distributor for details on Spectrum '71 or write Jerrold Electronics Corporation, Distributor Sales Division, 401 Walnut Street, Philadelphia, Pa. 19105.



*Focusing on one thing...
better reception*

a GENERAL INSTRUMENT company

Circle 72 on reader service card

SURPLUS TTL INTEGRATED CIRCUITS, BRAND NEW IN ORIGINAL MANUFACTURERS CARTONS

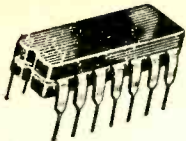

B & F has one of the worlds largest inventories of surplus integrated circuits. All are new, meeting all manufacturers original specifications, and in factory packaging. The low prices should speak for themselves. Manufactured

by Texas Instruments, National, Signetics or Philco, no choice. All packages are 14/16 lead silicone Dual In-Line Pak. Write for additional RTL and DTL lines not listed. Many other I. C. items in stock including nixies, 5 volt power supplies, indicators, logic breadboards.

- 7400 Quad 2-Input NAND Gate \$.50
- 7401 Quad 2-Input NAND Gate50
- 7402 Quad 2-Input NOR Gate50
- 7404 Hex Inverter50
- 7405 Open Collector Hex Inverter50
- 7408 Quad 2-Input AND Gate50
- 7410 Triple 3-Input NAND Gate50
- 7411 Triple 3-Input AND Gate50
- 7420 Dual 4-Input NAND Gate50
- 7421 Dual 4-Input AND Gate50
- 7430 8-Input NAND Gate50
- 7440 Dual 4-Input NAND Buffer50
- 7441 BCD To Decimal Decoder Driver 3.00
- 7450 Dual 2-Wide 2-Input Expandable A-O-I Gate50
- 7451 Dual 2-Wide 2-input A-O-I Gate50
- 7453 4 Wide Expandable 2-Input A-O-I50
- 7454 4 Wide 2-Input A-O-I50
- 7460 Dual 4-Input Expander50
- 7470 J-K Flip-Flop 1.00
- 7472 J-K Master Slave Flip Flop 1.00
- 7473 Dual J-K Master Slave Flip-Flop 1.00
- 7474 Dual D Flip-Flop 1.00
- 7475 Quad Bistable Latch 1.75
- 7476 Dual J-K Master Slave Flip-Flop 1.00
- 7480 Full Adder 1.50
- 7490 Decade Counter 2.00
- 7491 8 Bit Shift Register 3.00
- 7492 Divide By 12 Counter 2.00
- 7493 4-Bit Binary Counter 2.00
- 8T01 NIXIE Decoder/Driver 3.00
- 8T04 Seven Segment Decoder/Driver 3.00
- 8162 Variable One-Shot 1.00
- 74192 Bidirectional Counter 3.00
- 74145 BCD to Decimal Decoder Lamp Driver 2.50

20% discount on orders for 100 or more integrated circuits. All I.C.'s postpaid, with FREE air mail on orders over \$50.00. We strive to ship I.C.'s by return mail. Free data sheets on all items.

Charges Welcome
BankAmericard — Mastercharge — \$10.00 min.
B. & F. ENTERPRISES
Phone: 617 532-2323
P.O. Box 44, Hathorne, Massachusetts 01937
Circle 73 on reader service card

NEW SEMICONDUCTORS

SOLID-STATE T/R SWITCH

The MCH5890 is designed primarily as a transmit-receive switch but can be used as a monitor network in

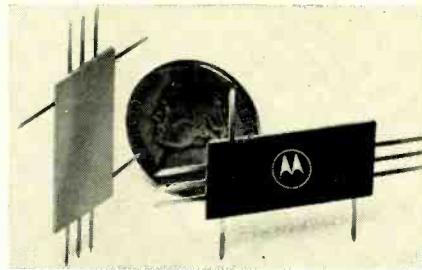

transmitter circuits, as a sampling network in afc or agc circuits and other related communications applications. This Motorola device features a typical 25 dB transmit-mode isolation figure and a typical 0.1 dB transmit-mode insertion loss.

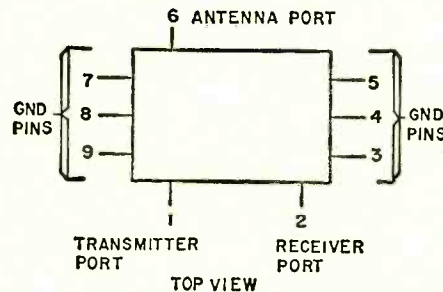

Designed for use at frequencies between 400 and 500 MHz, the device handles up to 40 watts maximum input. Available in plastic and ceramic 631 cases, the body is approximately 1

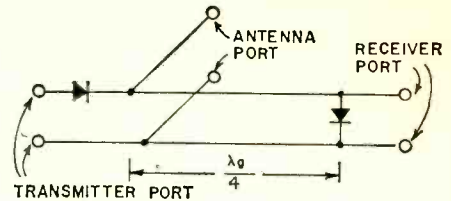

IMPEDANCE Z OF EACH ARM IS 50Ω,
λ_g IS THE WAVELENGTH.

inch long, 0.5 inch wide and about 0.04 inch thick. The drawings show the lead connections and the equivalent parallel-wire representation.

COMPLEMENTARY EPOXY TRANSISTORS

The EN3903, EN3904, EN3905 and EN3906 are epoxy TO-106 electrical replacements for the npn 2N3903 and 2N3904 and pnp types 2N3905 and 2N3906. The TO-106 package has a triangular pin layout that permits leads to be inserted in a conventional socket without having to be preformed. 1-99 prices for these Fairchild transistors are: \$0.75 for EN3903 and EN3905 and \$0.82 for the EN3904 and EN3906.

Shopping Power For Your Dollar

FREE \$1 BUY WITH EVERY 10 YOU ORDER

FREE GIFT WITH EVERY ORDER

SARKES TARZIAN TUNER
41mc
Latest Compact Model good for all 41 mc TV's.
BRAND NEW—

Best TUNER "SARKES TARZIAN" ever made—last word for stability, definition & smoothness of operation. An opportunity to improve and bring your TV Receiver up-to-date.
\$7.95
COMPLETE with Tubes

- UHF TUNER — TRANSISTOR TYPE Used in all TV sets \$3.95
- STANDARD TUNER — TRANSISTOR (GUIDED GRID) 4 Channel closed circuit \$1
- COLOR POWER TRANSFORMER — Good for most sets 26R150 List Price—\$36.75 \$6.95
- 5 ASSORTED GLOBAL VARIATOR Popular replacements for most COI-OR TV \$1
- 10—ASSORTED SLIDE SWITCHES SPST, SPDT, DPDT, etc. \$1
- 20 — DIPPED MYLAR CAPACITORS .01—600V \$1
- 20 — DIPPED MYLAR CAPACITORS .033—600V \$1
- 20 — DIPPED MYLAR CAPACITORS .0033—1000 V \$1

- TV TUNER — asst. all new standard makes. Less tubes \$1
- RCA COLOR FLYBACK Part #113382 (Stancor #HO-601C) \$12.95
- HEAVY DUTY COLOR FOCUS RECTIFIER 14,000 PIV @ 1 ma \$1
- 50 — OIL IMPREGATED TUBULAR CAPACITORS Porcelain Axial Leads—Most popular values \$3.95
- COLOR-TV RECTIFIER — Used in most color sets—6500 kv \$1.95
- 15 — ASST. ROTARY SWITCHES all popular types \$20 value \$1
- 15 — G.E. #NE-2 TUBES Neon Glow Lamp for 101 uses \$1
- 50 — .0033 DISC CERAMIC CAPACITORS C.R.L. \$1
- 3—ELECTROLYTIC CONDENSERS most popular number 50/30—150V \$1
- 7 — TV ELECTROLYTIC CONDENSERS desirable types \$1
- 12—MINIATURE ELECTROLYTIC CONDENSERS For Transistor & miniature work \$1
- 10 — MINIATURE 456KC IF TRANSFORMERS Exceptional value —PC—1 1/2" x 1 1/2" \$1
- 25 — #130 WESTINGHOUSE PILOT BULBS 5000 Hours Same as #47 \$1
- UHF OR VHF MATCHING TRANSFORMER Simple Fool-proof installation \$1
- 3—ELECTROLYTIC CONDENSERS C.D. 500 mfd—200 volts \$1
- 20 — DIPPED MYLAR CAPACITORS .01—400 V \$1

- 3' JUMPER CABLES Male RCA type Plug on Both Ends. 2 For 50 — ASST. TERMINAL STRIPS all types. 1-lug to 6-lug \$1
- 2—G.E. PIECES OF EQUIPMENT stacked with over 200 useful parts \$1
- S20 — SHURE M7D DIAMOND NEEDLE exact replacement \$3
- MATCHED PAIRS TRANSISTORS NPN & PNP (2N4252-2N2904) (2N2222-2N2907) Each set \$1
- RONETTE STEREO CARTRIDGE latest dual sapphire flipover type \$2
- 6 — TRANSISTOR RADIO EARPIECES wires complete with plug 100" — FINEST NYLON DIAL CORD heat size. 028 gauge \$1
- 10 — SETS PHONO PLUGS & PIN JACKS RCA type \$1
- 3—PRINTED CIRCUIT IF TRANSFORMERS 4-lug. 456 KC \$1
- 25 — 3900-OHM-7w RESISTOR 10% Corning glass \$1
- 20 — 47-600V CONDENSERS White Ceramic C.D.—American \$1
- 13 Pc. SCREWDRIVER & NUTDRIVER SET regularly \$8.95 \$4.50
- ENCLOSURE WITH 6" SPEAKER Excellent value. regularly \$14.95 \$5.95
- SHURE M44 SERIES DIAMOND NEEDLE exact replacement \$4.69
- 4 — 9 VOLT MOTORS Excellent for hobbyist \$1
- 200' — #24 SOLID PUSH BACK WIRE Yellow or Black excellent buy \$1
- 70° COLOR TUBE BRIGHTNER \$3.95
- 90° COLOR TUBE BRIGHTNER \$4.95

- TRANSISTOR RADIO asst type good, bad, broken, as-is, potluck \$1.50
- TAPE RECORDER—assorted types good, bad, broken, as-is, potluck \$4
- 300 — ASST. 1/2 W RESISTORS Top Brand. Short Leads. Excellent Selection \$1
- 100—ASST 1/4 WATT RESISTORS stand, choice ohmages, some in 5% \$1
- 100—ASST 1/2 WATT RESISTORS stand, choice ohmages, some in 5% \$1
- 70 — ASST 1 WATT RESISTORS stand, choice ohmages, some in 5% \$1
- 35 — ASST 2 WATT RESISTORS stand, choice ohmages, some in 5% \$1
- 50 — PRECISION RESISTORS asst. list-price \$50 less 98% \$1
- 20 — ASSORTED WIREWOUND RESISTORS, 5, 10, 20 watt \$1
- 4 — TOGGLE SWITCHES SPST, SPDT, DPST, DPDT \$1

KNOB SPECIAL

- 100 — ASSORTED RADIO KNOBS All standard types \$20 value \$1
- 50 — TV KNOBS — POPULAR TYPES For most sets \$1
- 25 VERTICAL LINEARITY KNOBS Long shank \$1
- 30 — VERTICAL LINEARITY KNOBS miniature assortment Standard sizes Side mount \$1
- 25—KNURLED RADIO KNOBS Hard to set. Best selection \$1
- 40 — DELUXE RADIO KNOBS Choice assortment Popular types \$1

ANY 6 KITS FOR \$5

IMMEDIATE DELIVERY . . . Scientific light packing for safe delivery at minimum cost.
HANDY WAY TO ORDER: Pencil mark or write amounts wanted in each box, place letter F in box for Free \$1 BUY. Enclose with check or money order, add extra for shipping. Tearsheets will be returned as packing slips in your order, plus lists of new offers.
Minimum Order \$3.00

Name Cost of goods
Address Shipping
..... estimated
..... TOTAL

Please specify refund on shipping overpayment desired: CHECK POSTAGE STAMPS MERCHANDISE (our choice) with advantage to customer

BROOKS RADIO & TV CORP., 487 Columbus Ave., New York, N. Y. 10024 212-874 5600 TELEPHONE

NEW BOOKS

THE NEW ELECTRONICS, by Bruce H. Shore. McGraw-Hill Book Company, 330 West 42 St., New York, N.Y. 10036. 6 x 9 1/2 in., 253 pages. Hardcover, \$10.

This is a non-technical guide that covers important developments in solid-state electronics during the past 20 years. Chapters explain fundamentals and history of hole-electron theory, thin films, memories, magnetic material, laser and holography, among others.

LINEAR INTEGRATED CIRCUITS MANUAL, IC-42, by RCA Solid State Division, RCA Commercial Engineering, 415-5th St., Harrison, N.J. 07029. 5 1/4 x 8", 416 pp. Softcover, \$2.50.

Latest innovations in integrated-circuit technology and applications in this guide for circuit and system designers, educators, technicians. Explains basic fabrication, packaging, mounting, and interconnection techniques, analyses fundamental building-block elements for linear monolithic integrated circuits. Also features application guide to circuit types for specific applications.—MCL

INTRODUCTION TO COMPUTER ENGINEERING, by B. S. Walker. Hart Publishing Co., 510 Sixth Ave., New York, N.Y. 8 3/4 x 5 3/4 in., 385 pp. Hardcover, \$12

Primarily intended for undergraduate engineers and technologists. First examines what the computer has to do and the most logical way to do it. Explains the fundamental principles and philosophies underlying computers and their applications.

DATA BOOK FOR ELECTRONIC TECHNICIANS AND ENGINEERS, by John D. Lenk. Prentice-Hall, Inc., Englewood Cliffs, N.J. 07632. 9 1/4 x 6 1/2 in., 185 pp. Hardcover, \$8.95.

Practical suggestions, tables and formulas for technicians at all levels. Contains frequently used equations and tables.

SMALL APPLIANCE REPAIR GUIDE, by Wayne Lemons and Glen Montgomery. Tab Books, Blue Ridge Summit, Pa. 17214. 224 pages, 5 1/4 x 8 1/4 in. Hardcover, \$7.95, softcover, \$4.95.

First chapter describes general troubleshooting procedures, others cover thermostats, skillets & pans, irons, toasters, coffee makers, blankets, mixers, small motors and many other appliances. Sections detail operation, tests and repair procedures.

COLOR-TV CASE HISTORIES, by Jack Darr. Howard W. Sams & Co., Inc., Indianapolis, Ind. 46206. 135 pages, 5-3/4 x 8-1/2 in. \$3.50.

Collection of case histories of color-TV troubles that have actually occurred in the field. The histories are arranged by manufacturer and chassis or model number. The particular complaint is listed first, and then the solution is given. The tuner, i.f.'s, color demodulators, degaussing circuits, focus circuits, picture tube, high voltage, and many more aspects are included, with schematics throughout. Good reading for experienced technicians and helpful to the novice by showing him what logical troubleshooting can accomplish. R-E

RADAR SPACE SWITCH

A Microwave Motion Detection System, designed to provide total premise protection by giving an alarm due to forced entry through roof, wall, door, or window.

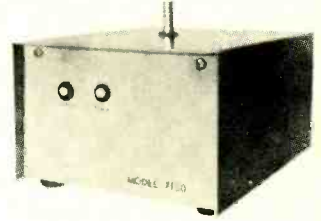

Model 7100

Designed to be interconnected with existing installations, other systems, or additional Space Switches. Two stage digital filter system eliminates false alarms. Complete tamper proof ON/OFF switching circuit. May be powered from 110 Vac or 12 Vdc. Small size, easy to camouflage. Solid state, single PC Board, constructed for easy maintenance. \$119.00 Each

artronix
INC.
SURVEILLANCE

716 Hanley Industrial Court, St. Louis, Mo. 63144
Area Code 314 Phone 644-2456

Circle 74 on reader service card

SHANNON MYLAR RECORDING TAPE

2 1/2" - 225' .. \$.17	7" - 2400'	\$1.79
3" - 225' .. .19	7" - 3600'	2.95
3" - 300' .. .27	CASSETTE 60 minutes	.89
3 1/4" - 600' .. .58	CASSETTE 90 minutes	1.54
5" - 600' .. .62	CASSETTE 120 minutes	1.97
5" - 900' .. .80		
5" - 1200' .. .97	2 1/2" TAPE REEL05
5" - 1800' .. 1.49	3" TAPE REEL06
7" - 1200' .. .77	3 1/4" TAPE REEL07
7" - 1800' .. 1.12	5" TAPE REEL14
	7" TAPE REEL15

CANADIANS: Ordering is easy — we do the paperwork — try a small order

WESTINGHOUSE ALL TRANSISTOR HOME/OFFICE MESSAGE CENTER

Leaves messages for other for replay... Built in speaker/microphone for talk-into convenience... Records up to 3 minutes of messages... Illuminated signal shows when a message is waiting. Control adjusts playback volume without affecting recording volume... Capstan Drive... BRAND NEW SOLD AS IS \$7.95

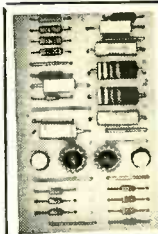

IBM COMPUTER SECTIONS

8 assorted Units we sell for \$1 are loaded with over 150 valuable parts.

Incl. — Transistors
Capacitors, Resistors,
Diodes, Etc.

8 for \$1
100 for \$10

RCA 110° FLYBACK TRANSFORMER

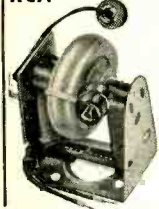

We scooped the Market Latest type — standard for all 110° TV's HCA's design of large Coil produces 18KV — assuring adequate width Incl Schematic Diagram application for any TV List price \$13.90

Your price \$3 100% off in lots of 3

110° TV DEFLECTION YOKE for \$3 all types TV's incl schematic

"COMBINATION SPECIAL" RCA 110° FLYBACK plus 110° DEFLECTION YOKE \$5

90° FLYBACK TRANSFORMER for all type TV's incl schematic \$2

90° TV DEFLECTION YOKE for all type TV's incl schematic \$2

70° FLYBACK TRANSFORMER for all type TV's incl schematic \$2

70° TV DEFLECTION YOKE for all type TV's incl schematic \$2

2 — TV CIRCUIT BREAKERS \$1.19 Rated 4.2 TO 5.0 AMPS, etc.

70° COLOR YOKE For all found color CRT's \$12.95

90° COLOR YOKE For all Rectangular 19 to 25" Color CRT's \$10.95

CO-AX CABLE RG59U grey of \$2 black 250' — \$9 100' — \$3.69 50'

4 — TV ALIGNMENT TOOLS \$1 most useful assortment #1

4 — TV ALIGNMENT TOOLS \$1.49 For Color TV #2

6 — TV COLOR ALIGNMENT TOOLS \$2.79 Most popular type

5 — PNP TRANSISTOR \$1 general purpose, TO-5 case

5 — NPN TRANSISTORS \$1 general purpose, TO-5 case

UNIVERSAL TV ANTENNA \$1.98 Back of set Mounting

5 section rods

50 — ASSORTED TRANSISTORS \$1 big factory scoop — sold as-is

0 TO 200 MICRO AMP MINIA-TURE METER 1 1/2 x 1 1/2" Wt. \$1 3 Oz. Excellent S meter

10 — STANDARD TRANSISTORS \$1 NPN & PNP 2N104, 2N144, etc.

10 — ASSORTED DIODE CRYSTALS \$1 1N34, 1N48, 1N60, 1N64, etc.

3 — TOP BRAND SILICON RECTIFIERS 1 amp 1000 PIV \$1 #44, 48, 47, 51, etc.

20 — ASST. PILOT LIGHTS \$1 #44, 48, 47, 51, etc.

4-50 HANKS HOOK-UP WIRE \$1 assorted colors

100 — SPOOL SPEAKER WIRE \$1.50 2 cond, mnl zip, clear, 101 uses

10 — ASST. RADIO & TV TUBES \$1 Every Tube a good number

5 — I.F. COIL TRANSFORMERS \$1 456-ke for Transistor Radios

5 — AUDIO OUTPUT TRANS-FORM Sub-min for Trans Radios

WESTINGHOUSE FM TUNER \$2.99 (12DTS Tube)

WESTINGHOUSE FM TUNER \$3.99 #476-V-015D01 Transistor

300 — ASSORTED HEX NUTS \$1 2/56, 4/40, 5/40, 6/32, 8/32

250 — ASST. SOLDERING LUGS \$1 best types and sizes

250 — ASST. WOOD SCREWS \$1 finest popular selection

250 — ASST. SELF TAPPING SCREWS #6, #8, etc. \$1

150 — ASST. 6/32 SCREWS and 150 6/32 HEX NUTS \$1

150 — ASST. 8/32 SCREWS and 150-8/32 HEX NUTS \$1

150 — ASST. 2/56 SCREWS and 150-2/56 HEX NUTS \$1

150 — ASST. 4/40 SCREWS and 150-4/40 HEX NUTS \$1

150 — ASST. 5/40 SCREWS and 150-5/40 HEX NUTS \$1

500 — ASSORTED RIVETS \$1 most useful selected sizes

500 — ASSORTED WASHERS \$1 most useful selected sizes

100 — ASST. RUBBER BUMPERS \$1 for cabinet bottoms & other uses

100 — ASSORTED RUBBER GROM-METS best sizes \$1

MARKET SCOOP COLUMN

CRYSTAL LAPEL MICROPHONE High Imped. 200-6000 cps .. 10 for \$5 .. 59¢ ea.

RCA COLOR FLYBACK Part #113382 (Stanco #110-601C) \$12.95

CAR BURGLARY ALARM KIT \$19.95 Easy to install System is complete. Includes 12V Siren, door, Hood, and trunk switches as well as on/off switchlock, mtg. brackets, wire, details, and easy to follow step-by-step instructions

6" UNIVERSAL SPEAKER Top Quality Special \$1.29 Ea Buy 10 for \$5

12" UNIVERSAL SPEAKER Top Quality .. Large Magnet \$4

10" PHILCO SPEAKER Top Quality .. Large Magnet \$2.69

8" UNIVERSAL SPEAKER — Large Magnet — Special Buy \$2.49

5" UNIVERSAL TWEETER 1 Oz. Magnet \$1.29

UNIVERSAL 4" PM SPEAKER With 50L8 Output Transformer \$1

2 1/2" x 4" SPEAKER Special Buy 10 For \$5 — 69¢ Ea.

3 1/2" — ROUND SPEAKER Special Buy .. 59¢

4" X 6" "QUAM" 16 OHM SPEAKER Large magnet .. Special BUY (10 for \$15.00) .. \$1.79

Circle 75 on reader service card



**CCTV
CAMERAS**

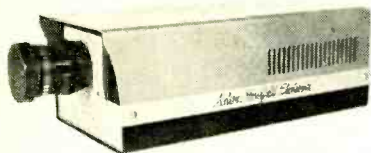

The Little Pro

Designed to compete in a class with the heavyweights, this outstanding performer in the six pound weight class is a guaranteed favorite. Satisfying most camera requirements with rugged silicon transistor design, the PB914 offers 4000 to 1 automatic light control, 550 line center resolution, electronically regulated power supply, and F 1.9, 25mm lens. Ideal for surveillance, security, industrial control or educational needs. For ringside information on the PB914 and other champs in our CCTV line, write, wire, or call

Nelson-Herskfeld Electronics

1848 WEST CAMPBELL AVE.
PHOENIX, ARIZONA 85015

PHONE
602.264.1348

Circle 76 on reader service card

**ANOTHER SUPERB
VALUE
from Olson
Electronics**



ONLY
\$12
DELUXE
TRANSISTOR
CHECKER

Compact, self-contained, self-powered dynamic transistor checker. Test may be made "in circuit" or out of circuit. Identifies and checks PNP and NPN types, plus power. Complete with instruction manual, service tips and transistor drawings.

Olson Electronics, Dept. LS

260 S. Forge St., Akron, Ohio 44308

I enclose \$12, send me the TE-199 Transistor Checker.

Send me the next seven issues of the Olson Catalog, without cost or obligation.

Name _____

Address _____

City _____

State _____ Zip _____

Circle 77 on reader service card

EQUIPMENT REPORT

Heathkit GR-169 Solid-State Portable Color Television Kit
For manufacturer's literature, circle No. 17 on Reader Service Card

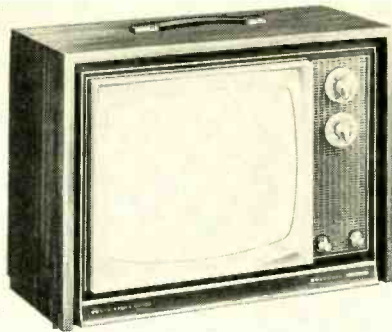

THIS KIT HAS MUCH TO RECOMMEND IT. IT IS completely solid-state except for the high-voltage rectifier and the picture tube. Also included are features such as degaussing from the front panel, bridge type low-voltage supply, plug-in PC boards, an attractive wood grain cabinet, and a built-in dot generator. A vom kit is also supplied to aid in initial check out and troubleshooting.

The kit arrived in two large boxes, one containing the cabinet and all components, the other the picture tube. In unpacking and checking parts we discovered both degaussing coils were missing. A note to Heath and we had the missing parts before we needed them.

There are four instruction manuals for this kit, in step with Heath's stage-by-stage assembly procedure. Book I covers assembly of the PC boards, all nine of them. Book II covers complete chassis assembly and picture tube installation. Book III details adjustment sequences and cabinet installation. Book IV contains troubleshooting data and specs.

The nine PC boards were assembled without any problem. PC boards are used for the sound i.f., luminance, video output, chroma, oscillator, age-sync, vertical oscillator, horizontal oscillator, and convergence. The boards each have a row of female pin sockets at each end, that interconnect them to each other and the chassis circuitry through chassis-mounted male pin plugs.

Book II covers chassis construction. Heath supplies the tuners, i.f. strip, and high voltage supply pre-assembled and adjusted. These units are attached to the chassis and wired in. There were no serious problems encountered in building the chassis, just some tight quarters to work in. Two large wiring harnesses included in the parts, cut down on assembly time as compared with earlier color sets. As usual, the instruction manual was clear and concise, save one point. The diagram and wording of the convergence pole piece and purity ring location on the neck of the picture tube were a bit difficult to follow.

The chassis design showed a good deal of thought. It was designed for easy service. Like other Heath color sets, the picture tube mounts to the front cover. The chassis is bolted in a "U" shape vertically to the front cover and is hinged so that one side can be unbolted from the cover and pulled back perpendicular

to the front cover exposing all the wiring inside. The PC boards plug in the back side of the "U" and are removable with just the back cover off.

With the construction of the set completed, we proceeded to resistance check-out as outlined in Book III. The small vom kit provided for this chore worked well and we found a pair of transposed leads in the yoke socket. Preliminary adjustments were made next, and the set turned on. A touch on the age, vertical and horizontal hold controls produced normal sound and a badly misconverged color picture. We went into the adjustment procedure and got as far as turning on the built-in dot generator. The dots went on, and went right off. Jiggling the dots switch brought them back momentarily. We removed the luminance PC board and resoldered everything, curing our intermittent in the process. We went into the convergence procedure and got a fair color picture. Successive reconverging got a much improved picture, but still not quite as we expected. We also had slight sound bars in the picture.

Several days later, with the set in normal operation, the degaussing switch was hit by accident and out went the circuit breaker. Troubleshooting with Heath's vom revealed that the horizontal output transistor and scan regulator transistor had shorted. Replacements were installed and we had a raster but no sound and no picture! Voltages around the tuner, i.f. strip and age-sync board were way off. After much headscratching we found a wire connected to the i.f. strip (part of the age line) unsoldered. A drop of solder put us back in business. We completely reconverged it again and were rewarded with an excellent color picture for two days. The picture went dead but we had sound. A new 3CU3, a HV rectifier cured that. We speculated that the failure of the horizontal circuit had weakened the tube.

Book IV, the troubleshooting manual, is really good. It should allow the owner of the set to make almost all repairs by himself. The book is profusely illustrated with pictures of possible operational difficulties and has suggestions next to each one for tracking each condition down. Factory repair service is offered for the PC boards for \$5.00 each, parts and labor.

With our initial problems behind us, we feel that this is a good portable. The color is better than many of the commercially built sets we have examined. Black and white pictures are black and white. Local reception with the built in rabbit ears is good. Fringe reception of course requires a good antenna but is also good. The factory rf-i.f. alignment is quite good and it probably will not be necessary ever to realign it. The finished appearance is up to the best of standards, and having all of the frequently adjusted controls up front is very handy. What more can you ask for? **R-E**

NOTEWORTHY CIRCUIT

4-CHANNEL AUDIO MIXER

The RCA CA3048 IC amplifier array consists of four independent identical amplifiers that can operate from a single power source. This 16-lead dual-in-line plastic packaged IC is ideal for use as an audio mixer when

The gain per stage from input to output, determined by the value of the feedback resistor between ground and the inverting (-) input, is 20 dB for the circuit constants shown. Gain of the individual stages is 34 dB but there is a loss of around 14 dB in the mixing

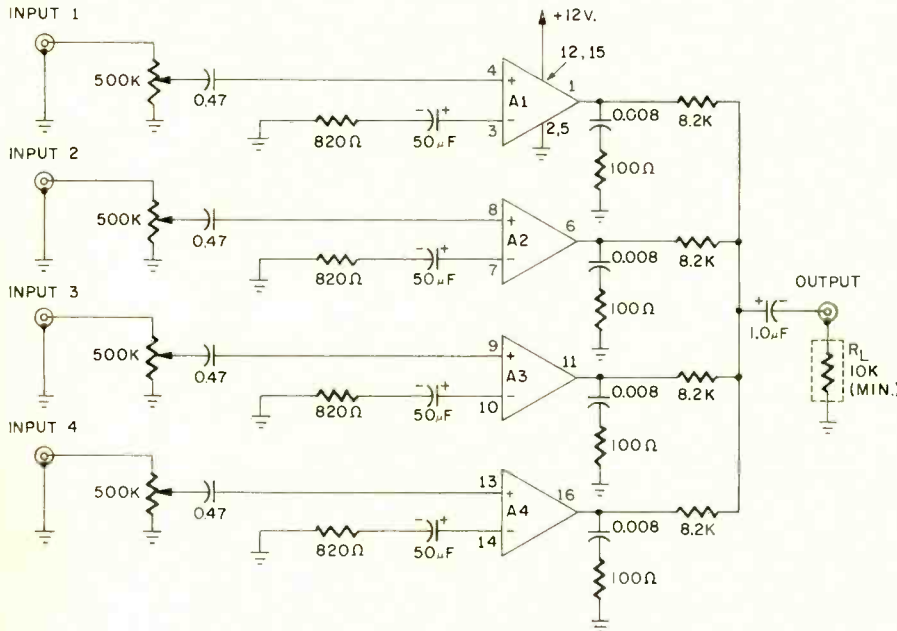

connected as in the diagram. This circuit is taken from Application Note ICAN-4072.

Each input signal is fed to the input of one of the four amplifiers through a 500,000-ohm gain-control pot and series dc blocking capacitors.

networks consisting of the 82,000-ohm series resistors and load R_L . The series R-C networks composed of .008- μ F capacitors and 100-ohm resistors stabilize the amplifiers when source and load conductances are too small to provide adequate damping. **R-E**

ALLIED RADIO SHACK ISSUES A NEW AND DIFFERENT CATALOG!

ELECTRONICS FROM A-Z
ANTENNAS
BATTERIES
CAPACITORS
DIODES
EDUCATIONAL KITS
FIBER OPTICS
GRILLE CLOTH
HI-FI SPEAKERS
IC'S - JACKS
KNOBS - L-PAOS
MIKES - NEEDLES
OSCILLOSCOPE - P-BOXES
QUADRACS - RESISTORS
SEMICONDUCTORS
TELEPHONES
ULTRASONIC ALARMS
VHF ANTENNAS - WIRE
XENON STROBE LIGHT
"Y" ADAPTERS
ZENER DIODES
AND MUCH MORE!

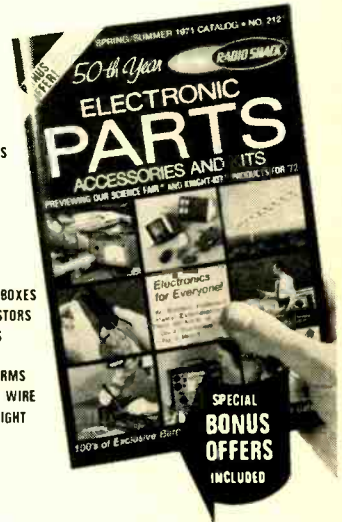

1000'S OF ITEMS,
100'S OF
EXCLUSIVES!

PREVIEWS OUR COMPLETE
SCIENCE FAIR® AND
KNIGHT-KIT® LINES FOR '72!

a valuable "FIRST EDITION"
...and it's **FREE!**

The new buying Guide for kit builders, Hams, hobbyists, do-it-yourselfers, "fix-it men"! Lists thousands of handy and wanted "little things" most stores don't stock. Like tubes and transistors, cables and plugs, adapters and antennas—you name it—the things that keep equipment working. Or make it work even better. Or DO MORE. If you own anything electronic or electrical, you need this catalog!

950 STORES NATIONWIDE!
EVERYTHING IN THIS BOOK
AVAILABLE FAST & EASY!

ALLIED RADIO SHACK Dept. RE-3

7275 W. 7th St., Fort Worth, Texas 76107

Send me your FREE Spring/Summer Cat. 212

Name (print) _____

Route No. _____ Box No. _____

Street _____ Apt. No. _____

City _____ State _____ Zip _____

NEW DELUXE COLOR ORGAN CIRCUITS! UP TO 35,000 WATTS

A.P.M. SYSTEMS CORP., MANUFACTURERS OF THE FINEST COLOR ORGANS IN THE WORLD, NOW OFFER YOU THE MOST ADVANCED AND POWERFUL COLOR ORGAN CIRCUITS.

AVAILABLE IN 3 AND 4 CHANNEL KITS FEATURING:

- Solid State (easy to assemble printed circuit).
- All UL listed components.
- 3 channel circuit - 2,670 watts - easily converted to handle up to 26,250 watts.
- 4 channel circuit - 3,556 watts - easily converted to handle up to 35,000 watts.
- Electronically balanced circuitry permits one step tuning.
- Wires to any popular sound system in the same manner as a speaker.
- 2 year unconditional guarantee on all parts.
- Easy to assemble kit form.

SEND TODAY

FREE color brochure
with each kit order.

A.P.M. SYSTEMS, INC.
1551 Almaden Rd.
San Jose, Calif. 95125

PLEASE RUSH ME MY A.P.M. COLOR ORGAN KIT, AS INDICATED BELOW:

Check box to indicate choice.

- 3 Channel Kit - \$37.95
 4 Channel Kit - \$54.95
 3 Channel Plans - 26,250 watts - \$2.00
 4 Channel Plans - 35,000 watts - \$2.00
 Color brochure on water swirls and living walls - \$.50

Check one box to indicate manner of payment.

- I enclose full payment. Ship kit postpaid.
 I enclose \$5.00 deposit. Ship kit C.O.D. for balance plus postage.

Name _____
 California residents: add 5% sales tax
 Address _____
 City & State _____ Zip _____

A.P.M. SYSTEMS, INC. Dept. M15
P.O. Box 9159, San Jose, Calif. 95117

MARKET CENTER

ELECTRONICS

RADIO and TV Tubes 36¢ each. One year guaranteed. Plus many unusual electronic bargains. Free Catalog. CORNELL 4217-E University, San Diego, California 92105

JAPANESE NEW PRODUCTS MONTHLY! \$1.00 Refundable. DEERE, P.O. Box 9308, No. Hollywood, Calif. 91609

PRINTED CIRCUITS Quick. Free Estimates. INDUSTRIAL PHOTO D-17, Oakhurst, N.J. 07755

B & K, Sencore test equipment, discount prices, Free catalog and price sheet. FORDHAM RADIO, 265 East 149th Street, Bronx, NY 10451

CONVERT any television to sensitive big-screen oscilloscope. Only minor changes required. No electronic experience necessary. Illustrated plans \$2.00. RELCO-A25, Box 10563, Houston, Texas 77018

TUBES, Transistor, Tapes. Get original Manufacturers' Parts. TV, Radio, American, Japanese, Dealer Discount. MARCUS, 43-35 44th Street, Long Island City, N.Y. 11104

COLOR CONVERTER FOR B&W TELEVISION. Electronic Patented system. Write for free Brochure. BELE ELECTRONICS CORP., 111 North-east Second Avenue, Miami, Fla. 33132

HAVE leaky batteries ever ruined your test equipment, radios, or anything battery operated? You can stop this. Materials furnished \$1.00. CAMCO, Box 5108, Ventura, Ca. 93003

250 WATT Linear. 10-15 Meters. Plans \$1.00. ROBERTS, Box 403, Whiting, Indiana 46394

RECEIVING & Industrial Tubes, Transistors, All Brands—Biggest Discounts. Technicians, Hobbyists, Experimenters—Request FREE Giant Catalog and SAVE! ZALYTRON, 469 Jericho Turnpike, Mineola, N.Y. 11501

FREE ELECTRONIC CATALOG. Tremendous bargains. EDU-KITS, Department C-262G, Hewlett, New York 11557

TV Cameras, Kits, Parts. Send \$1.00 for Details. MOJAVE ELECTRONICS, 9036 Pauhasca, Apple Valley, Ca. 92307

INTEGRATED CIRCUITS—Factory Prices, Catalog 10¢. SILLING COMPANY, Box 6257, Seattle, Washington, 98188

TUBES—Lowest prices. Foreign-American. Obsolete, receiving, special purpose, transmitting tubes. Send for tube, parts catalog. UNITED RADIO COMPANY, 56-R Ferry St., Newark, N.J. 07105

DISCHARGE Ignition, Photoflash. Free catalog parts, kits. TRANSPARK, Carlisle, Mass. 01741

COLOR TV convergence generator—solid state. Kit \$29.95, wired \$39.95 or request brochure. REY-SAL, Box 5253 Garden Grove, Ca. 92645

AUDIO - HI-FI

STREAM, a bygone era captured on tape. The finest recording ever made. Now available reel to reel or cassette. Write CALTAPE, Dept. H, P.O. Box 5716, Redwood City, Ca. 94063 \$4.95 p.p.

RENT 4-track open reel tapes—all major labels—free brochure. STEREO-PARTI, 55 St. James Drive, Santa Rosa, Ca. 95401

R-E ON FILM

Two sources of filmed back issues of RADIO-ELECTRONICS are now available. Please write the companies for further information. Microfilm editions are available from University Microfilms, A Xerox Company, Ann Arbor, Mich. 48106. Beginning with the January, 1969, issue, Microfiche editions are available from NCR Microcard Editions, Industrial Products Division, 901 26th St., N.W., Washington, D.C. 20037.

CLASSIFIED ADVERTISING ORDER FORM

1	2	3	4	5
6	7	8	9	10
11	12	13	14	15
16	17	18	19	20
21	22	23	24	25
26	27	28	29	30
31	32	33	34	35

No. of Words { @ .60 Non-Commercial Rates } = \$
 { @ .90 Commercial Rate } = \$
 No. of Words in bold caps @ .10 = \$

Total Enclosed \$ _____
 Insert _____ time(s)
 Starting with _____ Issue

Payment must accompany order unless placed through accredited advertising agency

NAME _____
 ADDRESS _____
 CITY _____ STATE _____ ZIP _____
 SIGNATURE _____
 MAIL TO: RADIO-ELECTRONICS, CLASSIFIED AD DEPT., 200 PARK AVE. SOUTH, NEW YORK, N.Y. 10003

U.S. GOV'T ELECTRONIC SURPLUS

Nationally Known-World Famous SURPLUS CENTER offers finest, most expensive, Government Surplus electronic units and components at a fraction of their original acquisition cost.

IBM COMPUTER POWER SUPPLY

- (ITEM #22-934) - Expensive, regulated unit. Fine for college labs, research co's, service shops, etc. Pure DC over a wide range of voltages. DC output voltages 6, 12, 48, etc. Wide range of AC voltages available.
- Finest transformers, filters, transistor load regulation system. Independent of line voltage fluctuations. Contains five separate rectifier systems. Unit is furnished without small "regulating card" which can be easily made or can be by-passed. Data and circuit diagrams furnished. 30" x 12" x 10". (125 lbs.)

Cost Gov't Over \$500.00 **\$24.95**

ONCE-IN-A-LIFETIME SPECIAL



BURGLAR-FIRE ALARM SYSTEM



\$29.95

- (ITEM #1135-A) - Dual alarm system gives warning of fire or break-in. Operates on 115-VAC. Control unit, 2-bay slide-rule 2-mercury column, 3-door window actuator, alarm bell, 100 ft. wire, instructions. 8 1/2" x 7 1/2" x 3". (7 lbs.)

STANDARD DIAL TELEPHONE

- (ITEM #715) - Standard commercial telephone same as used throughout U.S.A. Attractive polished black, like new condition. Use as extension phone to private systems or connect several phones together for local intercom system. Full instructions are furnished. Rt. 9 lbs.



Original Cost **\$7.49**

STEP-BY-STEP TELEPHONE SWITCH

- (ITEM #7-905) - Amazing telephone selector switch. Great experimental item. When used with ten-wire telephone dial will select any number from 0 to 100. Make intercom or private system. Use to turn on remote lights, start motors, etc. Comes with contact bank. 17" x 6" x 5". (16 lbs.) Cost over \$90.00



\$6.29

- Telephone dial for use with above switch. (Order as (Item #700).....) **\$1.97**

MAGNETIC DIGITAL COUNTER (12 to 18-VDC)

- (ITEM #21-959) - Use to count electronically. Use to count number of times door is opened after business is closed, to show changing prices, laboratory uses, etc. Will count 1 for each pulse and will transfer 10th count to next unit. 4 1/2" x 1 1/2" x 1 1/2". (1 1/2 lbs.)



Orig. Cost Over \$19.00 Each **\$1.99** Three For **\$4.99**

TYPICAL BUYS FROM OUR 1972 CATALOGS

- \$ 10.00 115-Volt DPDT Relays..... **\$1.69**
- \$101.00 Regulated Transformer, Wide Range..... **\$14.91**
- \$ 15.00 20-Relay Telephone Panel..... **\$4.39**
- \$250.00 Gyroscope, Twin Rotor, 24V..... **\$9.89**

AC PROGRAM TIMING CLOCK

- (ITEM #158) - Zenith 115-VAC unit. Use for periodic signaling work breaks, classes, turn on radio, etc. bill, clips permit ON-OFF switching any time in 24-hour period. Also has "night" feature. Can be multiple programmed. 15 amp. contacts. 8 1/2" x 8 1/2" x 2". (8 lbs.)



Cost Gov't Over \$30.00 **\$15.75**

SNAP AROUND VOLT-OHM-AMMETER

- (ITEM #21-944) - Measures AC current without opening the line. Simply press handle and snap the probe around the conductor. Reads currents from .25 to 125-amps. Reads voltages to 200, reads ohms up to 500. Test motors, appliances, etc. Three current ranges, two voltage ranges. With case, test leads. 7 1/2" x 3" x 1 1/2".



Reg. Price \$36.95 **\$36.90** (2 lbs.)

SPECIAL SALE

Correspondence Course In ELECTRICAL ENGINEERING **\$8.79** (Prepaid in U.S.A.) **\$10.79** Outside U.S.A.



- (ITEM #A180) - Obtain technical training at low cost! Lincoln Engineering School has suspended its Correspondence Courses because of rising costs. A limited number of Electrical Engineering Courses are available, but without the examination grading service. The course consists of 15 lesson books, each with associated exams and standard answers. Book describing prize winning Home Experimental Laboratory Bench furnished at no extra cost.

RUNNING TIME METER

- (ITEM #2188) - Record number of operating hours of electric lights and electrical devices such as refrigerators, furnaces, etc. Records total hours, tenths and hundredths up to 9,999.99 hours. For 115-volt, 60-cycles. Size 4 1/2" x 3" x 2 1/2". Shipping weight 2 lbs.



\$4.39 Cost Over \$29.00

COMPUTER TRANSISTORS ON HEAT SINKS

- IBM Computer Quality Units
- (#22-928) - Unit consists of one 150-watt power transistor on heavy, ribbed, aluminum heat sink. Many experimental uses. (1 lb.)



Cost Gov't Over \$10.00 **\$1.99**

- (#22-915) - Unit consists of two 150-watt power transistors, 2 pots, several diodes, capacitors, resistors, etc. on heavy, ribbed aluminum heat sinks. Ideal for use as motor speed control. (4 lbs.)



Cost Gov't Over \$35.00 **\$4.91**



All items shipped f.o.b. Lincoln, Neb. Order Direct From Ad. Money Back Guarantee.

SURPLUS CENTER
 DEPT. RE-071 LINCOLN, NEBR. 68591

RADIO-ELECTRONICS

rectifiers, resistors, etc., and push-on terminals for connecting the primary, high-voltage and indicator lamp leads. The resonating capacitor is mounted on one side of this case.

The grid-filter unit will be specially designed to fit inside the ducts used with the heating/cooling system. These will vary in size and shape, but functionally, all the same. Fig. 2 shows a schematic

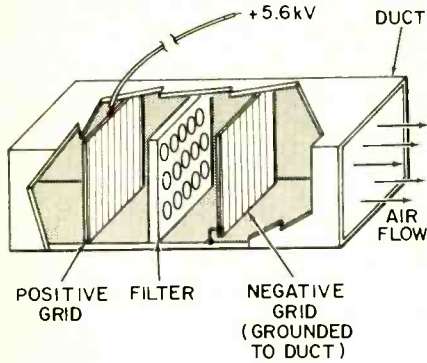
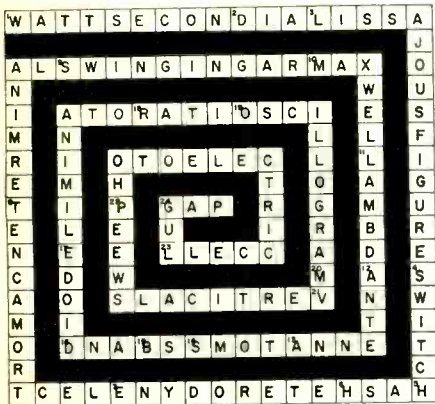

Fig. 2

layout of this kind of unit. (Spacing between the grids and filter have been exaggerated to show construction.)

This is still another instance of how we can make use of the very basic principles of electronics to do things. Any electronics technician can repair such things with ease if he remembers his basic theory and uses a little ingenuity in selecting replacement parts. These are often available, off-the-shelf, in parts houses! R-E

Answer to puzzle on page 42



NOW build your own Capacitor Discharge Ignition System for as little as \$11.45! Circuit diagram included with special ignition transformer.

TR-200 transformer
6 or 12 volts 11.45

Complete COMPAC KIT
6 or 12 volts 25.95

(as described in
POPULAR ELECTRONICS—Nov. 1966)

FREE LITERATURE on all SYDMUR "CD" Systems.

SYDMUR—P.O. Box 25, Midwood Station,
Brooklyn, N.Y. 11230

Unijunction Metronome

A metronome is necessary to learn timing in music. This circuit generates timing clicks for practicing music. Many photographers also use a metronome for timing enlargement exposures by adjusting it for 1-second pulses. This simple circuit has a wide range and is very stable. The potentiometer can be calibrated with another metronome, or at the slower speeds, by counting pulses.

PARTS LIST

- 1 HEP 310 or 2N4871 unijunction transistor
- 1 250,000-ohms potentiometer
- 1 6800 ohms, 1/2 watt, 10% resistor
- 1 330 ohms, 1/2 watt, 10% resistor
- 1 0.05- μ F, 25-volt capacitor
- 1 0.5- μ F, 25-volt capacitor
- 1 10- μ F, 25-volt electrolytic capacitor
- 1 9-volt battery

DID YOU MISS?

IC power supplies on page 49 shows how to use a μ A723 to build simple, yet precise regulated power supplies. If you need a Dancing Strobe Light to complete your music system take a look at page 46. This simple circuit turns an ordinary fluorescent light into a psychedelic device.

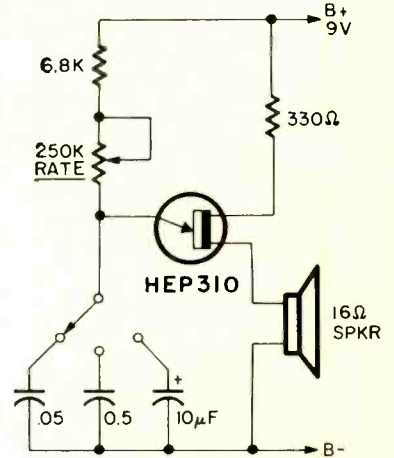

CLASSIFIED COMMERCIAL RATE (for firms or individuals offering commercial products or services). 90¢ per word . . . minimum 10 words.

NON-COMMERCIAL RATE (for individuals who want to buy or sell personal items) 60¢ per word . . . no minimum.

FIRST WORD and NAME set in bold caps at no extra charge. Additional bold face at 10¢ per word. Payment must accompany all ads except those placed by accredited advertising agencies. 10% discount on 12 consecutive insertions, if paid in advance. Misleading or objectionable ads not accepted. Copy for Sept. issue must reach us before July 1.

INTEGRATED CIRCUITS & RECTIFIERS SEMICONDUCTORS & TRIACS

BCD COUNTER KIT consisting of:

- 1—PC Board 12707
- 2—7476 IC's
- 2—Silicon diodes
- 1—Set of instructions

When assembled by enclosed instructions, this kit will count pulses from 0-9 in BCD. These boards can be connected in series to count as high as desired. Example, two will count to 99, three to 999. \$6.95

ER900 TRIGGER DIODES. These bidirectional trigger diodes are one of the best and cheapest methods to trigger SCR's and triacs . . . 4/\$1.00

LIGHT EMITTING DIODES (LED's)
Infra red \$1.50
Visible \$1.50
Photo detectors for each . . \$1.00

TRIACS

PRV	1A	10A	15A
100	.40	.70	1.00
200	.70	1.10	1.40
300	.90	1.35	1.80
400	1.10	1.60	2.20
500	1.50	2.00	2.60

NIXIE TUBES

Similar to Raytheon 8754 with socket & data sheet \$4.75

TTL IC SERIES

- 7441 BCD DECIMAL DECODER \$2.00
- 7474 DUAL FLIP FLOP . . . \$.85
- 7475 QUAD BISTABLE LATCH \$1.70
- 7476 DUAL JK MASTER-SLAVE JK FLIP FLOP \$1.00
- 7490 DECADE COUNTER \$1.85
- 7492 DIVIDE BY TWELVE \$1.85
- 7493 4 BIT BINARY COUNTER \$1.85

Silicon Power Rectifiers

PRV	3A	12A	30A
100	.09	.24	.40
200	.12	.28	.60
400	.16	.35	.90
600	.20	.50	1.10
800	.28	.70	1.40
1000	.35	.90	

Terms: FOB Cambridge, Mass. Send check or Money Order. Include Postage. Average Wt. per package 1/2 lb. No. C.O.D.'s. Minimum Order \$3.00

DECADE COUNTER KIT

CONSISTING OF:
1—NIXIE TUBE and SOCKET
1—7490 1—7475 1—7441
Specially priced at \$9.95

Controlled Avalanche or Epoxy Rectifiers 1 AMP.

PRV	.06	600	.11
100	.06	600	.11
200	.07	800	.15
400	.09	1000	.20

LINEAR CIRCUITS

709C operational Amp . . \$.80
741 operational Amp . . \$1.25
SE 501 Video Amp . . . \$1.25

Silicon Control Rectifiers

PRV	3A	7A	20A	70A
50	.25	.28	.60	
100	.30	.38	.85	3.50
200	.50	.60	1.10	6.50
300	.60	.68	1.30	
400	.70	.75	1.50	9.50
500	.80	.85	1.70	
600	.90	1.20	1.90	11.00

TIS 43 General purpose Unijunctions \$.50
2N3819 General purpose N-Channel FET'S \$.45

Send for our latest catalog featuring Transistors and Rectifiers; 325 Elm St., Cambridge, Mass.

OLID

Post Office Box 74D

TATE

Somerville, Mass. 02143

ALES

Tel. (617) 547-4005

Circle 83 on reader service card

MARKET CENTER

COMMERCIAL-FREE FM BACKGROUND MUSIC: Musicon MX-7 solid state SCA adapter plugs into any FM tuner or receiver. Compact, no adjustments. 5 year sub-carrier reception guarantee. It works with your equipment or money back, promptly! FREE-list of SCA stations with order. Send \$39 (ppd) check or M.O. to: K-LAB, Box 572(W), So. Norwalk, Conn. 06856. SPECIAL-MX-6 wire-in-yourself mini-module (9V operation) \$29.

TRADE Stereo Tapes. \$1.25 each postpaid. Minimum: three. **TAPETRADE**, Box 2181, LaJolla, Calif. 92037

STEREO TAPE TRANSPORT-7" reel-2 speed-pause control-made for famous manufacturer-50 to 15,000 Hz with rec/play and erase heads, without case. Send M.O. or check for \$19.50 to **STEREO CENTER**, 218 Columbia St., Utica, N.Y. 13502. \$2.50 for prepaid shipping and insurance.

RECORDING ENTHUSIASTS—IMPROVE RECORDINGS Inexpensive impedance converters terminate microphones properly, while allowing cable extensions to 500 feet without performance deterioration. Switchbox—handles—to three recorders, for dubbing, editing, and mixing. **WRITE:** Aids to Recording, **RUSSOUND/FMP**, Dept. 3, P.O. Box 476, Exeter, NH. 03833

EDUCATION/ INSTRUCTION

MEMORIZE, Study: 1971 Test-Answers" for FCC First and Second Class License—plus—"Self-Study Ability Test." Proven. \$9.95. **COM MAND**, Box 26348-E, San Francisco, Calif. 94126

TV TUNER REPAIRS—Complete Course Details, 12 Repair Tricks, Many Plans. Two Lessons, all for \$1. Refundable. **FRANK BOCEK**, Box 3236 (Enterprise), Redding, Calif. 96001

PSYCHEDELIC LIGHTING MANUAL. Make strobes, kaleidoscopes, organs, etc. Send \$2.95. **LIGHTTRAYS**, 1315-C Weaver, Philadelphia, Pa. 19150

INVENTIONS & PATENTS

INVENTIONS Wanted. Patented; Unpatented. **GLOBAL MARKETING**, 2420-AE 77th Ave., Oakland, Calif. 94605

SCHOOL DIRECTORY

GET INTO ELECTRONICS

V.T.I. training leads to success as technicians, field engineers, specialists in communications, guided missiles, computers, radar and automation. Basic & advanced courses in theory & laboratory. Electronic Engineering Technology & Electronic Technology curricula both available. Associate degree in 29 mos. B.S. also obtainable. G.I. approved. Graduates in all branches of electronics with major companies. Start Sept., Feb. Dorms, campus. High school graduate or equivalent. Catalog. **VALPARAISO TECHNICAL INSTITUTE**
Dept. C, Valparaiso, Indiana 46383



GOVERNMENT SURPLUS

JEEPS Typically from \$53.90 . . . Trucks from \$78.40 . . . Airplanes, Typewriters, Boats, Clothing, Camping, Sporting, Photographic, Electronics Equipment. Wide Variety, Condition. 100,000 Bid Bargains Direct from Government Nationwide. Complete Sales Directory and Surplus Categories Catalog. \$1.00 (Deductible First \$10.00 Order From Our Separate Included Catalog.) **SURPLUS SERVICE**, Box 820-REL, Holland, Mich. 49423

MANUALS for surplus electronics. List 25¢. **BOOKS**, 4905 Roanne Drive, Washington, D.C. 20021

WANTED

QUICK CASH . . . for Electronic EQUIPMENT, COMPONENTS, unused TUBES. Send list now! **BARRY**, 512 Broadway, New York, N.Y. 10012. 212 WALKER 5-7000

GENERAL

WHOLESALE Prices on Brand Name W Walkie-Talkies, Amplifiers, Telephone intercoms, Television Tubes (70% off), Alarms. Send for free catalog. **GAMMA ELECTRONICS**, 429 Central Avenue, Harrison, New Jersey 07029

Rebuild Your Own Picture Tubes?

With Lakeside Industries precision equipment, you can rebuild any picture tube!

For complete details, send name, address, zip code to:

LAKESIDE INDUSTRIES
5234 N. Clark St.
Chicago, Ill. 60640
Phone: 312-271-3309



PARTS! CORNELL TUBES!
FREE Send For FREE
CORNELL'S
New Color
Catalog
48 Pgs. New Items
IN LOTS OF 100
33¢ per tube
36¢ per tube
ORDER FREE
IF NOT SHIPPED
IN 24 HOURS!
4215 E UNIVERSITY AVE. SAN DIEGO, CALIF. 92105

ENJOY THE "MUSIC ONLY" FM PROGRAMS

M. A. D.

MUSIC ASSOCIATED'S DETECTOR
for continuous, commercial-free music
with ANY FM tuner or receiver



Kit \$49.50 Wired \$75.00 Cover \$4.95 List of FM stations that transmit "Music Only" programs \$1.00. Excellent F.M. Monaural Tuner with M.P.X. Jack \$50.00.

MUSIC ASSOCIATED
65 Glenwood Rd.,
Upper Montclair, N.J. 07043
phone 201-744-3387

ADVERTISING INDEX

RADIO-ELECTRONICS does not assume responsibility for any errors which may appear in the index below.

READER SERVICE CARD NO. PAGE

	Allied Radio Shack	69, 75
	Allied Radio Shack, Franchise Division	63
	A.P.M. Systems, Inc.	75
74	Artronix Surveillance Inc.	73
73	B&F Enterprises	72
61	B&K (Division of Dynascan Corp.)	62
75	Brooks Radio & TV Corp.	72-73
1	Castle T.V. Tuner Service, Inc.	Cover II
4	Chemtronics, Inc.	17
6	Cleveland Institute of Electronics	54-57
7	CosCo Research	58
	CREI, Division of the McGraw-Hill Continuing Education Co.	61
68	Delta Electronics Co.	68
3	Delta Products Corp.	16
79	Edmund Scientific Co.	80
63	EICO, Electronic Instrument Co., Inc.	66
	EMC, Electronic Measurement Corp.	12
	Grantham School of Engineering	28-31
	GTE, Sylvania	1
2	Heath Co.	7
64	Indiana Home Study Institute	66
80	International Crystal Mfg. Co.	Cover III
72	Jerrold Electronics	71
69	Kikusui Electronics	68
67	National Camera Supply	68
	National Radio Institute	8-11
76	National Technical Schools	5
	Nelson Hirshfield Electronics	74
77	Olson Electronics	74
71	Pennwood Numechron Co.	70
62	RCA Electronic Components, Test Equipment	64
	RCA Institutes	18-21
8	RCA Parts & Accessories	Cover IV
	Rye Industries	59
9	Schober Organ Co.	59
66	Sencore, Inc.	67
65	TDK Electronics Corp.	66
70	Workman Electronic Products, Inc.	70
5	Xcelite, Inc.	32

MARKET CENTER 76-79

Cornell Electronics
Lakeside Industries
Music Associated
Polypaks
Solid State Sales
Surplus Center
Sydmur Electronics

SCHOOL DIRECTORY 78

Valparaiso Technical Institute

MINIMOD—A NEW TYPE OF IC PACKAGE

MULTIBOND™ AND MINIMOD™ ARE two new G-E techniques for automatically fabricating and packaging integrated circuits. In IC construction, literally thousands of transistors, diodes and resistors are fabricated and interconnected on silicon semiconductor wafers about 2 inches in diameter. After testing, the circuits are cut apart into chips that go to make up individual IC's. Although the IC chips are made in batches of thousands, the complete manufacturing process is slowed drastically as skilled operators, working under high-power microscopes, use precision tools to weld individual gold wires as connecting links between the minute connection pads around the periphery of the tiny silicon chip and the lead frame of the IC package.



The new Multibond method of automatically bonding leads to the IC chip in one step (up to 72 leads can be bonded in less than 3 seconds) and the miniMod packaging concept provide smaller size, better performance and greater reliability and facilitates automatic handling and testing.

Basic to the Multibond and miniMod techniques is a continuous length of a special type of 35-mm film with indexing holes along the edges similar to the sprocket holes on ordinary 35-mm photographic film. Other perforations are made to accept the IC pellet and to provide access to the copper leads that are to be attached to the pellet.

A strip of very thin (1 ounce) copper is laminated to the film and photolithography is used to etch a lead frame into the copper at each index point. Each lead in the frame is etched down to a 4-mil wide finger at the point where it is to be bonded to a gold bump on the pellet. Lead frames are then tinned in preparation for pellet attachment.

In the meantime, the IC wafers have been tested and sawed into chips that will go into the individual devices. A glass coating has been deposited

It's The Biggest! It's The Most Popular PENNY SALE IN THE INDUSTRY!

ONE CENT

"EYE SEE" BONANZA BY POLY PAK

• With Spec Sheets • Lowest Prices in U.S.A. • Brand New



Buy ONE at the special "Sale" price get the SECOND for only ONE CENT!

Type	Description	Each	2 for
SN7400N	Quad 2 Input NAND Gate	\$0.88	\$0.89
SN7402N	Quad Input NOR Gate	.88	.89
SN7410N	Trip 3 Input NAND Gate	.88	.89
SN7420N	Dual 4 Input NAND Gate	.88	.89
SN7430N	8 Input NAND Gate	.88	.89
SN7440N	Dual 4 Input NAND Buffer	.88	.89
SN7441N	BCH-to-Nixie Driver	3.95	3.96
SN7460N	Dual 4 Input Expander	.88	.89
SN7473N	Dual J-K Flip Flop	1.19	1.20
SN7474N	Dual "D" Flip Flop	1.19	1.20
SN7475N	Quad Latch	2.95	2.96

SN7481N	16 Bit Memory	4.50	4.51
SN7490N	Decade Counter	4.50	4.51
SN7491N	8 Bit Shift Register	4.95	4.96
SN7492N	Divide By Twelve Counter	4.95	4.96
SN7493N	4 Bit Binary Counter	4.95	4.96

GENERAL ELECTRIC 3.5 WATT AUDIO PA263 AMPLIFIER



Only \$3.95

3 for \$10

Delivers 3.5 watts continuous, 10 watts peak. With heat sinks; micro-mini size: 3/4 x 1/2 x 1/2". 9 to 30V supply. High sensitivity, 8 to 16 ohm. For mono & Stereo phonos, tape, FM, AM, TV, servo.

SPRAGUE- IC's

Your Choice

- 908 Full Adder
- 909 Buffer
- 912 Half Adder
- 913 Shift Register
- 915 Dual 3 In. Gate

3 for \$1

- 4 — 2N4409 Nixie tube drivers 1.00
- 10 — 1Amp 800 piv silicon rectifiers . . 1.00
- 8 — 1Amp 1000 piv silicon rectifiers . . 1.00

LIGHT EMITTING DIODES

\$1.50 Any 2 for \$2.69

- Visible LED "brite red"
- Visible "brite red" sensor*
- Invisible infra-red LED
- Invisible infra-red sensor*



* With built-in Darlington amplifiers

10¢ Catalog on Fiber Optics, 'IC's', Semis, Parts

Terms: add postage. Rated: net 30, coll's 25%. Phone Orders: Wakefield, Mass. (617) 245-3829. Retail: 211 Albion, St., Wakefield, Mass.

POLY PAKS

P.O. BOX 942 R LYNNFIELD, MASS 01940

Circle 84 on reader service card

over the entire circuit except for the bonding pad areas. Gold bumps have been plated over the exposed pad areas.

The pellets are then aligned under the frame fingers and a gang tool applies heat and pressure to all fingers simultaneously, thus forming a rugged gold bond that withstands temperatures in excess of 280°C. The pellet is

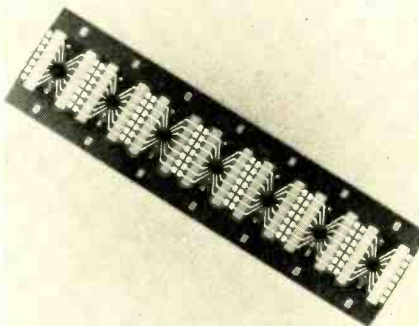

then encapsulated in plastic to complete the package.

MiniMod devices come off the assembly line on a continuous film strip that is wound on reels similar to those used for movie film or recording tape. A 25-foot holds 300 miniMod devices. (I'm waiting for the day that I can go to my parts-supplier and order 2 1/2 feet of miniMods.)

In use, the miniMods are cut out

of the strip with a shear or ordinary scissors and then soldered onto a PC board.

The GEL1741 op amp—identical electrically to the type 741—and the PA1494 Accu-Switch™ threshold detector are the first G-E products to be made with these new techniques. Other miniMods by mid-year. **R-E**

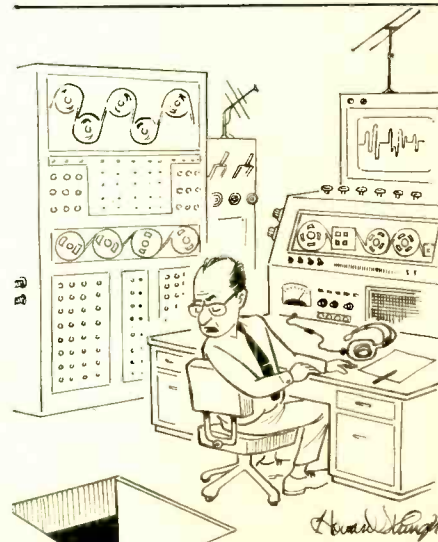

"That funny little button was for people who look over my shoulder, and keep asking questions about all the funny little buttons."

KEEP PACE WITH SPACE AGE! SEE MOON SHOTS—LANDINGS, SPACE FLIGHTS, CLOSE-UP!

AMAZING SCIENCE BUYS

for FUN, STUDY or PROFIT

FREE GIANT CATALOG!

3-CHANNEL COLOR ORGAN BARGAIN!

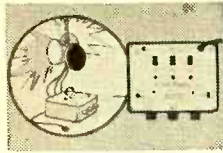

Create tremendous variety of unusual & beautiful lighting effects with this low-cost top-quality 1500-Watt unit (500 W. per channel). Compare with other selling for twice the price. Has pilot light, plus individual sensitivity controls and channel indicator lights. Can operate ten 150 W. "spots" or 200 Christmas lights. Uses reg. house current—attaches to audio source via RCA-type phone plug. 5 1/4" x 6 3/4" x 2 1/2". Thermal setting plastic case. 6 ft. cord. Including complete instructions.
Stock No. 71.223EH \$44.50 Ppd.

PSYCHEDELIC LIGHTING HANDBOOK



100 information-packed pages! Fully explains latest in psychedelic lighting equipment, techniques, developments. Covers all facets of psychedelic light-show production including strobes, black lights, projectors, crystals, optical mirrors, color organs, polarized color, light boxes, Music-Vision, etc. 8 1/2" x 11" looseleaf paper for 3 ring binder.
Stock No. 9100EH \$3.00 Ppd.

LONG-WAVE BLACK LIGHT FIXTURE

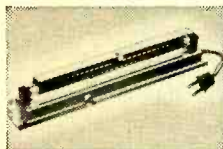

Extremely versatile, compactly designed, long wave (3200-4000 angstroms) black light (ultraviolet) fixture—eliminates harmful shorter wave ultraviolet rays. Use to identify minerals, fungi, bacteria—check for surface flaws, oil and gas leakage—perfect for displays with fluorescent paper, paints, chalk, crayons, trace powder. Incl. adjustable aluminum reflector, push-pull switch, connecting plug. Mount vert., horiz., or on corner. 10" L., 1 1/2" W., 1 1/4" H.
Stock No. 70.364EH \$12.50 Ppd.
Stock No. 60.124EH REPLACEMENT BULB \$4.75 Ppd.

1st LOW-COST VACUUM PUMP!



Nothing like it! Top-quality hand-held pump produces & maintains 25" of vacuum. Has instant release (ab. 1 1/2" diam. stainless gauge (0-30"). 100's of uses—siphon noxious fluids, evacuate bell jars and castings, clean, retrieve, lift, sterile objects, demonstrate Magdeburg hemispheres, bleed fuel lines, check leaks, etc. Lifts Lifter (2 1/2" diam. cup)—40 lbs. with included "T" much more w/ larger cup.
Stock No. 71.301EH \$12.00 Ppd.
Stock No. 71.300EH (without gauge/lifter) 5.50 Ppd.

BLACK-LIGHT MIGHTY MITES



Relatively small (12") fixtures give surprisingly bright blacklight. Mirror-finished reflector makes instant starting 8-watt, high-intensity bulb look like 40-watter. Up to 5,000 hours of safe, long-wave (3660A) black-light to really turn on parties, light & theatrical shows, psychedelic decors, holiday decorations. Shockproof end-caps remove for safe, easy replacement of bulb and starter. Stands upright or horizontal. Alum. case.
Stock No. 71.274EH \$14.95 Ppd.
DELUXE OUTDOOR/INDOOR MODEL
Stock No. 71.299EH \$19.95 Ppd.

INVISIBLE BLACK-LIGHT SPRAY



You can't see it under normal light, but under black-light, wow! It gives an eerie bluish-white glow to hundreds of things you'll think of for startling luminous effects. Create party costumes, decorations. Spray hidden messages around. Use on plastic, glass, wood, metal, styrofoam, papier maché, even fresh flowers! Washes off with any dry-cleaning fluid. Net contents: 13 oz. (enough to cover a 7 ft. Christmas tree with plenty left over).
Stock No. 71.276EH \$3.50 Ppd.

MAIL COUPON FOR GIANT FREE CATALOG



148 PAGES—1000's OF BARGAINS
Completely new 1971 edition. New items, categories, illustrations. Dozens of electrical and electromagnetic toys, accessories. Enormous selection of Astronomical Telescopes, Unique lighting items, Microscopes, Binoculars, Magnifiers, Magnets, Lenses, Prisms. Many war surplus items. Mail coupon for catalog.
EDMUND SCIENTIFIC CO.
300 EDSCORP BUILDING
BARRINGTON, N.J. 08007

NAME _____
ADDRESS _____
CITY _____ STATE _____ ZIP _____

EDMUND SCIENTIFIC CO. 300 EDSCORP BLDG. BARRINGTON, NEW JERSEY 08007
ORDER BY STOCK NUMBER • SEND CHECK OR MONEY ORDER • MONEY-BACK GUARANTEE

Circle 79 on reader service card

WHAT GOOD IS A DEAD BATTERY?

No good! So a genius invented this imported portable (2" x 4 1/2" x 1 3/4") Battery Tester whose built-in meter tells you at a glance if a battery is good, weak or should be replaced. Now it's a simple matter to check a flashlight or battery-operated toy and avoid frustration. Tester works without clips, wires or light attachments, and can be used for any "D", "C" or penlight 1.5 volt cells and 9 volt transistor radio battery. Instructions included.
Stock No. 60.812EH \$5.00 Ppd.



3" ASTRONOMICAL TELESCOPE

See moon shots, orbits-stars, phases of Venus, planets close up. 60 to 180 power. Aluminized and overcoated 3" diameter F/10 primary mirror, ventilated cell. Equatorial mount with locks on both axes. Equipped with 60X eyepiece and mounted Barlow lens. 3X finder telescope. hardwood tripod.
FREE "STAR CHART": 272-page "HANDBOOK OF HEAVENS": "HOW TO USE YOUR TELESCOPE"
Stock No. 85.030EH \$29.95 Ppd.
Stock No. 85.105EH \$94.50 FOB
Stock No. 85.086EH \$239.50 FOB



LOW COST TREASURE FINDER

Discover the fun and profit of treasure hunting inexpensively. Light as a feather (10 oz.) solid-state metal detector finds hidden coins, jewelry, precious minerals. Distinguishes minerals from metal objects. Great for school, beach, campground or backyard. Requires 9V transistor batt. Works with any common AM transistor radio thus eliminating costly extra circuitry, weight, dangling wires. Adjustable multi-purpose plastic handle reduces immediate area metal—adds to efficiency. No tuning needed.
Stock No. 71.395EH \$14.95 Ppd.



1ST LOW-COST XENON STROBE!

Price breakthrough in bright, reliable electronic strobes. 50W/Second xenon tube. Variable flash rate—60 to 500 per minute. Long life—more than 1,000,000 flashes. Price credit board design. Safe, durable Bakelite case. Externally mounted bulb, plastic shield. 6 1/4 x 3 3/4 x 2 1/4 oz. Perfect for psychedelic, stop action lighting effects for home light shows.
Stock No. 71.342EH \$24.95 Ppd.
BUILD-IT-YOURSELF STROBE KIT
Stock No. 71.343EH \$19.95 Ppd.



1st QUALITY OPAQUE UNDER \$200

Terrific Buy! Top Quality! Projects brilliant, sharp 4 1/2 ft. sq. image from 8" using up to 5"x5" color, b&w illustrations. Retains all original colors, proportions. Enlarges drawings, coins, maps, etc. Revolutionary peanut-size quartz Halogen lamp (50 hr. life), 200mm anastigmatic lens (f3.5, 8" F.L.) unique internal reflecting system give maximum brightness, entire field focus. Can be used upside down. Turbo-cooled. 5 1/2 ft. cord.
Stock No. 71.272EH (Wt 11 1/4 lbs.) \$89.75 Ppd.

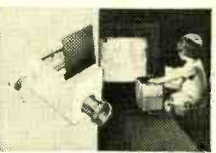

ASTRONOMICAL TELESCOPE KITS

Grind your own mirror for powerful telescopes. Kits contain fine annealed pyrex mirror blank, tool, abrasives, diagonal mirror, and eyepiece lenses. Instruments you build range in value from \$75 to hundreds of dollars. Excellent internal reflecting system give maximum brightness, entire field focus. Can be used upside down. Turbo-cooled. 5 1/2 ft. cord.
4 1/2" DIAMETER—3/4" Thick
Stock No. 70.003EH \$10.75 Ppd.
6" DIAMETER—1" Thick
Stock No. 70.004EH \$13.95 Ppd.
8" DIAMETER—1 1/2" Thick
Stock No. 70.005EH \$21.50 Ppd.
10" DIAMETER—1 3/4" Thick
Stock No. 70.006EH \$52.50 FOB



MINIATURE MODULAR COMPUTER

Play games, solve puzzles & problems, perform experiments. Fascinating new fun way to learn computer logic. 4 fully assembled circuits (clock, "hand" gate, flip-flop, display) enable you to make 100's of circuits impossible with simple static logic. Make any gate needed by combining hand gates. Learn how 2 hand gates keep come memory cell into which you can load data and read from. No special knowledge, tools or equipment needed. Self-teaching 74-bk. bklt. Req.—6V batt.
Stock No. 71.403EH \$39.75 Ppd.



Parts Storage Made Easy

A constant problem facing the experimenter is the storage of parts. Most of us either toss everything into one large box, and waste valuable construction time hunting for the required parts; or we use numerous boxes of widely differing sizes and shapes and waste storage space.



The ideal solution would be to use one standard size container. However, finding a container which is large enough to hold a reasonable number of larger parts, while not swallowing up the smaller items is impossible. Therefore a system using two sizes was developed and has functioned admirably for a number of years with no problems. The first container to be chosen was one suitable for storage of small parts, up to and including standard size i.f. transformers. The container selected was a standard miniature tube stacker. These are designed to hold ten miniature tube cartons, and are available for a few dollars a hundred from numerous radio supply houses. The tube stacker will hold a couple of hundred resistors, or ten standard i.f. transformers.

The larger container for transformers, speakers, etc. posed a more difficult problem, and many containers were tried before the final selection was made. The container selected is an 11 by 8 by 5 inches deep carton which originally held a dozen cans of beer. Other containers of similar size could be used; but preparation of the cartons for use provides the best part of the project.

This system is easily expandable to accommodate an increasing stock, in which case the parts may be subdivided, ie 1/2-watt and 1-watt resistors in separate boxes.

These containers are the ideal solution to that jumble of junk in the basement. They are cheap, simple, tidy and easily expandable. Who could ask for more?—D.J. Holford R-E

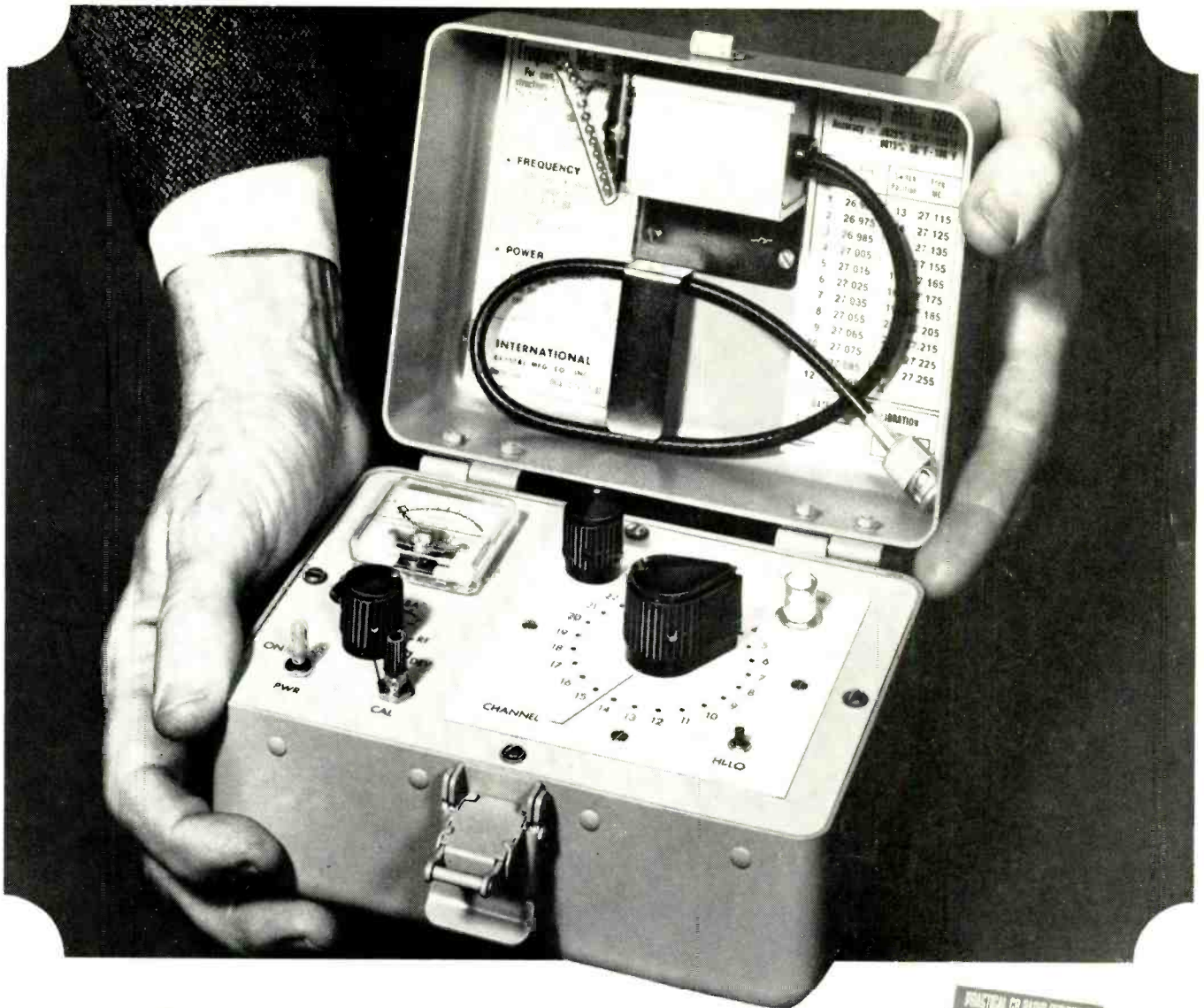

three in one...

INTERNATIONAL'S 6024 FREQUENCY METER

- SECONDARY FREQUENCY STANDARD
- SIGNAL GENERATOR
- POWER METER

The 6024 packs three test instruments into one small package for fast, professional servicing on all makes of Citizens Radio transceivers. You have at the flick of a switch, a SECONDARY FREQUENCY STANDARD, range 26.965 to 27.255 MHz with Counter Circuit, zero to 2500 Hz; SIGNAL GENERATOR, 26.965 to 27.555 MHz and DUMMY LOAD/POWER METER, up to 5 watts.

Order your International 6024 today!

Complete with connecting cable, dummy load, rechargeable battery and charger. **\$345⁰⁰**

PRACTICAL CB RADIO SERVICING

A reference manual for CB'rs, servicemen and students

This book covers virtually every servicing problem faced by CB radio enthusiasts, technicians, servicemen, and students. It provides all the theory and detailed procedures needed to repair and maintain equipment in a professional manner. Ideal tool for spot-testing and trouble shooting. Complete with tables and charts. **\$4.75** postpaid

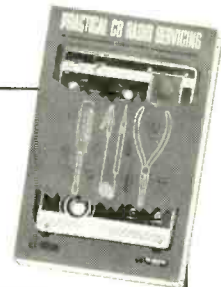

WRITE FOR CATALOG



CRYSTAL MFG. CO., INC.
10 NO. LEE • OKLA. CITY, OKLA. 73102

Circle 80 on reader service card

Announcing car tape stereo from RCA. The name that means music. And business.

A name that means music to your customers means more business to you. And RCA has meant both since music and electronics got together over 50 years ago.

But we've put more than just our name on our new car tape stereos. We've built in the same quality and fidelity your customers have come to expect from RCA. And we back them with outstanding parts, service data, and warranty programs.



Stereo 8 12R300

Plays all 8 track stereo cartridges. Exceeds 18 watts peak power. Automatic channel selection. Fast loading. Dramatic styling. Recessed controls.



Cassette Play | Record 12R200

Plays all cassettes. Makes recordings with a remote control mike. Fast forward and rewind. Automatic pop-out cassette ejector. Exceeds 18 watts peak power.



Cassette Play Only 12R100

Same as 12R200 less record feature.



Stereo Speaker Kit 12R400

Matched speakers plus hardware. Frequency response 50 to 10,000 Hz. Heat and moisture resistant.



Counter Display MDA-916

This impressive merchandiser demonstrates all the exciting features of these stereos. It's a beautiful reminder that RCA does mean music. And business. Ask your RCA Distributor to show you the complete line of effective promotion material available for your use.

RCA

Car Tape Stereo

At your RCA Distributor now!

Parts and Accessories | Deptford, N.J.